

# City Council Meeting

COUNCIL CHAMBERS, 33 SOUTH MAIN STREET, COLFAX, CA

Mayor Joe Fatula · Mayor Pro Tem Marnie Mendoza  
Councilmembers · Kim Douglass · Sean Lomen · Trinity Burruss

## REGULAR MEETING AGENDA

June 26, 2019

Closed Session 6:30PM

Regular Session: 7:00PM

### 1 CLOSED SESSION

- 1A. Call Closed Session to Order
- 1B. Roll Call
- 1C. Public Comment on Closed Session Items
- 1D. Closed Session

Conference with Legal Counsel – Anticipated Litigation. Significant exposure to litigation pursuant to Government Code Section 54956.9(d)(2): One potential case.

### 2 OPEN SESSION

- 2A. Call Open Session to Order
- 2B. Pledge of Allegiance
- 2C. Roll Call
- 2D. Approval of Agenda Order

*This is the time for changes to the agenda to be considered including removal, postponement, or change to the agenda sequence.*

**Recommended Action:** By motion, accept the agenda as presented or amended.

### 3 PRESENTATION (NO PRESENTATIONS SCHEDULED)

### 4 PUBLIC HEARING

**Notice to the Public:** City Council, when considering a matter scheduled for hearing, will take the following actions:

1. Presentation by Staff
2. Open the Public Hearing
3. Presentation, when applicable, by Applicant
4. Accept Public Testimony
5. When applicable, Applicant rebuttal period
6. Close Public Hearing (No public comment is taken, hearing is closed)
7. Council comments and questions
8. City Council Action

*Public Hearings that are continued will be so noted. The continued Public Hearing will be listed on a subsequent council agenda and posting of that agenda will serve as notice*

#### 4A. **Public Hearing on the written report of delinquent sewer service charges and delinquent refuse collection fees**

**Staff Presentation:** Laurie Van Groningen, Finance Director

**Recommendation:** Conduct a Public Hearing to consider public and staff comments and adopt separate resolutions 23-2019 and 24-2019 requesting collection of delinquent sewer and refuse collection fees on the Placer County Tax Roll for Tax Year 2019-2020.



- 4B. **Public Hearing on the Site Plan Review for Lorang Brothers RV and Self-Storage at 1175 S. Auburn Street**  
**Staff Presentation:** Amy Feagans, City Planner  
**Recommendation:** Conduct a Public Hearing, discuss and consider adopting Resolution 25-2019 approving the Site Plan Review for 1175 S. Auburn Street to develop an RV and Self-Storage Facility.

## **5 CONSENT CALENDAR**

*Matters on the Consent Agenda are routine in nature and will be approved by one blanket motion with a Council vote. No discussion of these items ensues unless specific items are pulled for discussion and separate action. If you wish to have an item pulled from the Consent Agenda for discussion, please notify the Mayor.*

**Recommended Action: Approve Consent Calendar**

- 5A. **Minutes – Regular Meeting of June 12, 2019**  
**Recommendation:** Approve the Minutes of the Regular Meeting of June 12, 2019.
- 5B. **Fiscal Year 2019-2020 Rate Adjustments**  
**Recommendation:** Information Only.
- 5C. **Unfunded Pension Liability**  
**Staff Presentation:** Laurie Van Groningen, Finance Director  
**Recommendation:** Information Only.
- 5D. **Sierra Oaks Sewer Improvements – Notice of Completion**  
**Recommendation:** Adopt Resolution 26-2019 accepting the Sierra Sanitary Sewer Improvement Project as complete and authorizing the recording of the Notice of Completion.
- 5E. **Sierra Oaks Estates Subdivision Improvements – Notice of Completion**  
**Recommendation:** Adopt Resolution 27-2019 accepting the Sierra Oaks Estates Subdivision Improvements as complete and authorizing the recording of the Notice of Completion.
- 5F. **Culver Street Rehabilitation Project – Phase I**  
**Recommendation:** Adopt Resolution 28-2019 accepting the design and specification and authorizing the City Manager to solicit bids for the construction of the Culver Street Rehabilitation Project – Phase I.

## **6 PUBLIC COMMENT**

*Members of the audience are permitted to address the Council on matters of concern to the public within the subject matter jurisdiction of the City Council that are not listed on this agenda. Please make your comments as brief as possible; not to exceed three (3) minutes in length. The Council cannot act on items not included on this agenda; however, if action is required it will be referred to staff.*

## **7 COUNCIL STAFF AND OTHER REPORTS**

*The purpose of these reports is to provide information to the Council and public on projects, programs, and issues discussed at committee meetings and other items of Colfax related information. No decisions will be made on these issues. If a member of the Council prefers formal action be taken on any committee reports or other information, the issue will be placed on a future Council meeting agenda.*

- 7A. **Committee Reports and Colfax Informational Items – All Councilmembers**
- 7B. **City Operations Update – City Manager**
- 7C. **Agency Partner Reports**



## **8 COUNCIL BUSINESS**

- 8A. **Colfax Net Variance to allow a reduced setback to permit installation of a 60-80-foot-high telecommunication tower with antennas**  
**Staff Presentation:** Amy Feagans, Planning Director  
**Recommendation:** Decide whether to grant, grant with modifications, or deny the requested variance.
- 8B. **Annual Appropriations Limit**  
**Staff Presentation:** Laurie Van Groningen, Finance Director and Amy Meyers, Maze & Associates  
**Recommendation:** Adopt Resolution 29-2019 certifying compliance with the 2018-2019 Appropriation Limitation and establishing the Appropriation Limitation for the 2019-2020 Fiscal Year.
- 8C. **Clerk Services Agreement**  
**Staff Presentation:** Wes Heathcock, City Manager  
**Recommendation:** Discuss consider and adopting Resolution 30-2019 authorizing the City Manager to enter into an agreement with the City of Auburn in an amount not to exceed \$29,530.
- 8D. **Ordinance No. 539 – An Ordinance Amending the Colfax Municipal Code Chapter 16.24 to Allow Amendment or Correction of Final Subdivision Maps**  
**Recommended Action:** Waive the second reading and by motion adopt the Ordinance No. 539 to allow Amendment or Correction of Final Subdivision Maps (Second Reading).

## **9 GOOD OF THE ORDER**

*Informal statements, observation reports and inquiries regarding the business of the City may be presented by council members under this agenda item or requests for placement of items of interest on a future agenda. No action will be taken.*

## **10 ADJOURNMENT**

---

I, Wes Heathcock, City Manager for the City of Colfax declare that this agenda was posted at Colfax City Hall and the Colfax Post Office. The agenda is also available on the City website at [www.Colfax-ca.gov](http://www.Colfax-ca.gov).



Wes Heathcock, City Manager

---

Administrative Remedies must be exhausted prior to action being initiated in a court of law. If you challenge City Council action in court, you may be limited to raising only those issues you or someone else raised at a public hearing described in this notice/agenda, or in written correspondence delivered to the City Clerk of the City of Colfax at, or prior to, said public hearing.

---





# Staff Report to City Council

## FOR THE JUNE 26, 2019 REGULAR CITY COUNCIL MEETING

**From:** Wes Heathcock, City Manager  
**Prepared by:** Laurie Van Groningen, Finance Director  
**Subject:** Public Hearing on the written report of delinquent sewer service charges and delinquent refuse collection fees.

*Budget Impact Overview:*

N/A:	Funded: ✓	Un-funded:	Amount:	Fund(s):
------	-----------	------------	---------	----------

**RECOMMENDED ACTION:** Conduct a public hearing to consider public and staff comments and adopt separate resolutions 23-2019 and 24-2019 requesting collection of delinquent sewer and refuse collection fees on the Placer County Tax Roll for Tax Year 2019-2020.

### Summary/Background

Colfax Municipal Code (the “Code”) Title 8 and Title 13, authorizes the City to collect delinquent sewer service charges and delinquent refused collection fees on the secured tax roll at the same time as general property taxes. The Code requires the City Council to adopt a Resolution(s) in order to collect the delinquent charges on the tax roll.

Separate written reports for collection of delinquent sewer service charges and delinquent charges for refuse collection services have been prepared and are on file with the City. The written report for delinquent sewer service charges contains a description of each parcel receiving sewer services and facilities and the amount of the delinquent sewer service charges. The written report for delinquent refuse collection charges includes the parcel number of each parcel of real property upon which the charges are delinquent, the name(s) of the owner(s) of the real property to which refuse collection services were provided, the street address of the property served, the period of service, and the amounts due including reasonable administrative charges. All charges reflected in the written report have been computed in conformity with the Code.

A public hearing is required before the proposed Resolutions can be adopted. Notice of the Public Hearing regarding the delinquent accounts was published in the Auburn Journal once each week for two successive weeks prior to the hearing in compliance with the Code. All property owners with a delinquent balance were notified in writing of the public hearing process within the times required by the Code.

The purpose of the hearing is to allow the Council to hear objections and protests to the reports. At the conclusion of the hearing, the Council may adopt, revise, change, reduce or modify any sewer service charge or charge for refuse collection services in either report, sustain or overrule any objections to either report and adopt or decline to adopt the reports as modified. If the reports are adopted with or without modification, the City will file them with the County Auditor-Controller. The charges reflected in the final reports will be collected at the same time as ad valorem property taxes and remitted to the City, subject to a 1% County administrative charge. Placer County requires a resolution containing specific provisions to be adopted in order to collect the delinquent charges on the tax roll.

### **Analysis**

This process is essential to properly collecting delinquent sewer service charges and delinquent refuse collection fees on the annual County tax roll. Without this process, the City would have to pursue separate collection efforts against each property owner.

There are \$94,587.30 delinquent Sewer charges and \$5,505.52 delinquent refuse collection fees due as of June 19, 2019. Applicable interest, penalty, and administrative fees will be added to the account balance before transfer to the County. These amounts will be paid to the City and deposited into the applicable funds and/or transferred to Recology as appropriate.

### **Recommendation**

Adopt resolutions 23-2019 and 24-2019 requesting collection of delinquent sewer and refuse collection fees on the Placer County Tax Roll for 2019-2020.

### **Attachments**

1. Exhibit A – Report of Delinquent Sewer Service Charges and Refuse Collection Fees (Revised Report Date June 19, 2019)
2. Resolution 23-2019
3. Resolution 24-2019

**EXHIBIT A**

**City of Colfax**

**Delinquent Sewer Service Charges and Refuse Collection Fees**

**Report Date: June 19, 2019**

**The attached reports include:**

- 1. Delinquent sewer accounts as of June 19, 2019 by individual account.**
- 2. Delinquent refuse collection accounts as of June 19, 2019**

\*\*\*\*\*

**Delinquent balances that remain unpaid as of the County filing deadlines will be placed on the tax rolls for 2019-2020.**

- 1. Unsecured (denoted as "US" on report) direct charges will be transferred to County by June 28, 2019.**
  - 2. Secured direct charges which represent the balance of the delinquent accounts will be transferred to County by July 26, 2019.**
- Applicable interest, penalty, and administrative fees will be added to the account balance before transfer to the County.**

## City of Colfax

Delinquent Sewer Accounts

Report Date: June 19, 2019

Location ID	Service Address	Total Due	Name	Prop ID
AUBN-000011-0000-00	11 N AUBURN STREET	\$620.40	SIMS/JULIE//	006073009000
AUBS-000150-0000-00	150 S AUBURN ST	\$1,714.28	GARGAN/STEPHANIE//	006103006000
AUBS-000300-0000-00	300 S AUBURN ST	\$833.76	WILLIAMS/KERN//	006143013000
AUBS-000313-0000-03	313 S AUBURN ST	\$1,714.28	MALNONADO/ISACC//	006141004000
BENT-024675-0000-00	24675 BEN TAYLOR RD	\$1,714.28	LOBNER/KAREN//	100120047000
CACC-000214-0000-00	214 CANYON CREEK CIR	\$1,714.28	CHAVEZ/JOSE//	101200031000
CACC-000300-0000-00	300 CANYON CREEK CIR	\$1,714.28	KEANE/LISETTE//	101200044000
CANC-000203-0001-00	203 CANYON COURT/333 CAN'	\$1,714.28	QUASAR LLC	101080030000
COLF-000015-0000-01	15 COLFAX AVE	\$1,714.28	DAHMEN/KIRSTIN//	006053007000
COND-000104-0002-00	104 CONDI LN	\$1,178.24	MEDEIROS/JOHN//	100260026000
CULV-000015-0000-00	15 CULVER ST	\$1,714.28	RAMEY/B.L.//	006063006000
DEPO-000009-0000-02	9 DEPOT STREET	\$2,738.02	STOECKLE/DAVID//	006043003000
DEPO-000055-0000-01	55 E DEPOT ST	\$2,299.91	QUIRK/LISA//	006042006000
FORS-000120-0000-00	120 S FOREST HILL AVE.	\$1,176.01	DAVE PORTER	006104008000
FORS-000128-0000-00	128 S FOREST HILL AVE.	\$1,124.67	SEARLES/JENNIFER & KASEY//	006104007000
FOST-000204-0000-02	204 FOSTER RD	\$1,714.28	THATCHER/STEPHEN//	100270027000
FOST-000210-0000-02	210 FOSTER RD	\$1,714.28	BARNARD/MICHAEL & DENISE//	100270024000
GEAR-000009-0000-00	9 GEARHART LN	\$1,714.28	GEM COUNTY SPECIALISTS LLC	006010006000
GEAR-000044-0000-00	44 GEARHART LN	\$1,714.28	GRACELYNN INTERPRISE, INC	006022002000
GLEN-000203-0001-00	203 GLENDALE RD	\$614.28	SANCHEZ/JUSTINO//	100270030000
GLEN-000204-0000-02	204 GLENDALE RD	\$1,124.67	MOON TUHEY/GREGORY//	100270032000
GRAV-023755-0000-00	23755 GRAND VIEW AVE	\$1,714.28	OSGOOD/BOB//	101161028000
H174-000323-0000-00	323 HWY 174	\$2,281.59	DELCASTILLO/NICOLE//	006143011000
HUNT-000120-0000-01	120 HUNTER LN	\$894.13	OSTER/JULIANNE//	006030061000
INCL-000230-0000-00	230 INCLINE DR	\$1,621.96	MCCORMICK/CHRIS//	101200017000
JEFF-000245-0000-00	245 JEFFERY PL	\$683.84	CURREY/VICKY//	006112018000
LINC-000029-0000-00	29 LINCOLN ST	\$1,714.28	ANDERSON/SELEN//	006093005000
MAIN-000007-0000-00	7 N MAIN ST	\$6,807.23	TODD/GARY//	850000150000
MAIN-000130-0000-02	130 N MAIN ST	\$4,221.78	KORAF CORPORATION	006043002000
MAIS-000121-0002-00	121 S MAIN ST	\$2,005.80	MORGAN RANCH LTD	006091007000
MARE-000121-0000-02	121 E MARVIN STREET	\$1,714.28	OHNMACHT/ROB//	006074009000
MINC-000116-0000-01	116 MINK CREEK DR	\$1,714.28	BARR/JASON//	100260053000
MOON-000560-0000-00	560 MOONRISE LN	\$817.90	MORGAN/JAMES//	101161039000
NEWM-000021-0000-00	21 NEWMAN ST	\$1,087.82	WREN/DOUG AND ROBYNN//	006092015000
NEWM-000033-0000-00	33 NEWMAN ST	\$833.76	KEYES/TIM//	006092008000
OAKE-000010-0000-00	10 E OAK ST	\$770.81	CAMPBELL/MARTHA//	006101009000
OAKE-000034-0000-00	34 E OAK ST	\$836.63	FIDDYMENT/KATHRYN//	006101007000
OAKH-000108-0000-00	108 OAK HILL DR	\$1,714.28	SCHWARTZ/KRIS//	006010046000
OAKH-000139-0000-00	139 OAK HILL DR	\$1,714.28	SARGENT/PHIL//	006010039000
OAKH-000140-0000-02	140 OAK HILL DR	\$1,714.28	HILTON/MATTHEW//	006010041000
OAKR-001334-0000-00	1334 OAK RIDGE DR	\$1,714.28	SHOBERG/KERRY//	100250044000
OAKW-000211-0000-00	211 W OAK ST	\$1,714.28	GONZALES/JIMMY & TIFFANY//	006080032000
PINS-000133-0000-02	133 PINE ST	\$859.24	QUENTMEYER/REBECCA//	006112060000
PINS-000155-0000-00	155 PINE ST	\$3,085.67	SMITH/VICKI//	006112063000
PLEA-000150-0000-00	150 PLEASANT ST	\$1,714.28	MARKLE/HELEN//	006030006000
PLEA-000455-0000-00	455 PLEASANT ST	\$1,621.62	COLLIER/JAMES//	006010051000
RISS-000230-0000-00	230 RISING SUN RD	\$1,714.28	HOLDERFIELD/KELLEY//	006080042000
ROSE-000333-0000-00	333 ROSE AVE	\$1,420.01	DESOTO/CHARLES//	006122002000
SHOL-000424-0000-00	424 SCHOLTZ AVE	\$1,442.53	RADFORD/PHILIP//	100130056000
SHOL-000444-0000-00	444 SCHOLTZ AVE	\$1,714.28	PRICE/WAYNE//	100130050000
TREA-000151-0000-02	151 TREASURTON ST	\$1,714.28	MARK/LISA//	100260013000
TREA-000170-0000-02	170 TREASURTON ST	\$1,124.67	LUCKMAN/NEISHA//	100260006000
TREA-000203-0000-00	203 TREASURTON ST	\$1,714.28	KLOSSNER/BRADLEY & KATIE//	100260036000
TREA-000212-0000-00	212 TREASURTON ST	\$750.21	LESTRANGE/DEBORAH//	100270016000
VIST-000212-0000-00	212 VISTA AVE	\$2,299.91	STRUVE/SARAH//	006045003000
WALN-000044-0000-00	44 WALNUT ST	\$1,714.28	MCSHANE/BETH//	006133005000
WIND-000115-0000-00	115 WINDER RD	\$1,124.67	KIPP/SAMUEL & SARA//	100260025000

<b>Total</b>	<b>57</b>	<b>\$94,587.30</b>
--------------	-----------	--------------------





# City of Colfax

## City Council

### Resolution № 23-2019

---

#### A RESOLUTION OF THE CITY COUNCIL OF THE CITY OF COLFAX REQUESTING COLLECTION OF SEWER SERVICE CHARGES ON THE PLACER COUNTY TAX ROLL FOR TAX YEAR 2019-2020

---

**WHEREAS**, Colfax Municipal Code Title 13, Chapter 13.08, Article VI authorizes the City of Colfax (the “City”) to collect delinquent sewer services charges which have accrued on the secured and unsecured tax roll in the same manner and at the same time as general property taxes; and

**WHEREAS**, a written report attached as Exhibit A to this Resolution (the “Report”) containing a description of each parcel of real property receiving sewer services and the amount of delinquent charges for each parcel has been prepared and filed with the City Clerk in accordance with Colfax Municipal Code §13.08.320; and

**WHEREAS**, notice of the filing of the Report and notice of the time and place of the hearing thereon by the City Council has been duly given and published as required by Colfax Municipal Code §13.08.330; and

**WHEREAS**, at the June 26, 2019 hearing the City Council heard and considered all objections and protests to the Report and determined that protests were not made by the owners of a majority of the separate parcels of property described in the Report; and

**WHEREAS**, at the conclusion of the hearing, after incorporating all revisions to the Report that the Council deemed necessary and after addressing or overruling all objections to the Report the Council found and determined that each charge as described in the Report is due, owing and unpaid; and

**WHEREAS**, the County has required as a condition of the collection of said charges that the City warrant the legality of said charges and defend and indemnify the County from any challenge to the legality thereof,

**NOW, THEREFORE, BE IT RESOLVED** by the City Council of the City of Colfax as follows:

1. The foregoing recitals are true and correct statements of fact and are hereby incorporated into this Resolution.

2. The Report attached as Exhibit A hereto is adopted and said adoption is final. The City Clerk is hereby directed to file with the Placer County Auditor-Controller a copy of this Resolution and the Report.

3. The Auditor-Controller of Placer County is requested to attach for collection on the County tax rolls those taxes, assessments, fees and/or charges, listed on the Report attached as Exhibit A attached hereto.

4. The City warrants and represents that the taxes, assessments, fees and/or charges imposed by the City and being requested to be collected by Placer County comply with all requirements of state law, including but not limited to Articles XIIC and XIID of the California Constitution (Proposition 218).

5. The City releases and discharges the County, and its officers, agents and employees from any and all claims, demands, liabilities, costs and expenses, damages, causes of action, and judgments, in any manner arising out of the collection by the County on the property tax roll of any taxes, assessments, fees and/or charges on behalf of the City.

6. In consideration for the County's collection of the charge through the County's property tax roll, the City agrees to and shall defend, indemnify and hold harmless the County, its officers, agents and employees (the "Indemnified Parties") from any and all claims, demands, liabilities, costs and expenses, damages, causes of action, and judgments, in any manner arising out of the collection by the County of any of the City's said taxes, assessments, fees and/or charges requested to be collected by the County for the City, or in any manner arising out of the City's establishment and imposition of said taxes, assessments, fees and/or charges. The City agrees that, in the event a judgment is entered in a court of law against any of the Indemnified Parties as a result of the collection of one of the City's taxes, assessments, fees and/or charges, the County may offset the amount of the judgment from any other monies collected by the County on behalf of the City, including property taxes.

7. The City agrees that its officers, agents and employees will cooperate with the County by responding to all inquiries referred to the City by the County from any person concerning the City's taxes, assessments, fees and/or charges, and that the City will not refer such persons to the County officers and employees for response.

8. The City agrees to pay the County for the reasonable and ordinary charges to recoup its costs of placement and collection on the tax rolls at the agreed upon rate of 1% of the taxes, assessments, fees and/or charges, as provided by Government Code sections 29304 and 51800.

**THE FOREGOING RESOLUTION WAS DULY AND REGULARLY ADOPTED** at the Regular Meeting of the City Council of the City of Colfax held on the 26<sup>th</sup> day of June 2019 by the following vote of the Council:

- AYES:**
- NOES:**
- ABSTAIN:**
- ABSENT:**

\_\_\_\_\_  
**Joe Fatula, Mayor**

**ATTEST:**

\_\_\_\_\_  
**Wes Heathcock, City Manager**

# City of Colfax

## City Council

### Resolution № 24-2019

---

A RESOLUTION OF THE CITY COUNCIL OF THE CITY OF COLFAX  
CONFIRMING THE REPORT OF DELINQUENT REFUSE COLLECTION  
ACCOUNTS AND PLACING LIENS ON SAID PROPERTIES AND SPECIAL  
ASSESSMENTS UPON PROPERTY TAXES PURSUANT TO CITY OF COLFAX  
MUNICIPAL CODE SECTION 8.20.130

---

**WHEREAS**, pursuant to Colfax Municipal Code Title 8, Chapter 8.20, subscription to, and payment for, Refuse Collection Service for all occupied properties in the City of Colfax is mandatory; and

**WHEREAS**, pursuant to the provisions of the Colfax Municipal Code, each owner of property for which there is a delinquency in payment for refuse collection services has been notified in writing of their obligation to subscribe to waste collection services and make payment for that service; and

**WHEREAS**, said property owners have been notified in writing of the commencement of lien proceedings; and

**WHEREAS**, Refuse Collection Service has been provided by Recology Auburn Placer to all properties described in the report attached hereto as Exhibit "A" and each of said properties remains delinquent in the payment for waste collection services in the amounts reflected in Exhibit A; and

**WHEREAS**, said property owners have failed to make payments for sixty days or more for waste collection services as required; and

**WHEREAS**, the City and Recology Auburn Placer have incurred collection and delinquency costs on the above described delinquent properties; and

**WHEREAS**, City staff has established an administrative charge of \$40 per parcel for processing the delinquent accounts and recording the assessment lien; and

**WHEREAS**, the City has, on June 26, 2019, held a duly noticed public hearing and afforded each delinquent property owner identified on Exhibit A to this Resolution the right to object to and protest the assessment lien for delinquent collection charges and administrative fees; and

**WHEREAS**, the City Council has reviewed, considered, revised and corrected the delinquent accounts report as it deems just.

**NOW, THEREFORE, BE IT RESOLVED** by the City Council of the City of Colfax as follows:

1. The City Council hereby confirms the report of delinquent accounts attached as Exhibit A hereto and made a part hereof and hereby places a lien and levies a special assessment against said properties in the amounts described.
2. The City Clerk is hereby authorized to record a certified copy of the confirmed report with the Placer County Recorder. Exhibit A may be amended to delete or reduce any enumerated refuse collection service charges and administrative costs paid before the special assessments authorized by this Resolution are forwarded to the Placer County Recorder.
3. The City Clerk is hereby directed to deliver a copy of this Resolution to the Placer County Auditor-Controller who is authorized to cause the above amounts to be collected in the manner provided by law for the collection of ad valorem taxes and special assessments.
4. The Auditor-Controller of Placer County is requested to attach for collection on the County tax rolls those taxes, assessments, fees and/or charges listed on Exhibit A attached hereto.
5. The City warrants and represents that the taxes, assessments, fees and/or charges imposed by the City and being requested to be collected by Placer County comply with all requirements of state law, including but not limited to Articles XIIC and XIID of the California Constitution (Proposition 218).
6. The City releases and discharges the County, and its officers, agents and employees from any and all claims, demands, liabilities, costs and expenses, damages, causes of action, and judgments, in any manner arising out of the collection by the County on the property tax roll of any taxes, assessments, fees and/or charges on behalf of the City.
7. In consideration for the County's collection of the charges through the County's property tax roll, the City agrees to and shall defend, indemnify and hold harmless the County, its officers, agents and employees (the "Indemnified Parties") from any and all claims, demands, liabilities, costs and expenses, damages, causes of action, and judgments, in any manner arising out of the collection by the County of any of the City's said taxes, assessments, fees and/or charges requested to be collected by the County for the City, or in any manner arising out of the City's establishment and imposition of said taxes, assessments, fees and/or charges. The City agrees that, in the event a judgment is entered in a court of law against any of the Indemnified Parties as a result of the collection of one of the City's taxes, assessments, fees and/or charges, the County may offset the amount of the judgment from any other monies collected by the County on behalf of the City, including property taxes.
8. The City agrees that its officers, agents and employees will cooperate with the County by responding to all inquiries referred to the City by the County from any person concerning the City's taxes, assessments, fees and/or charges, and that the City will not refer such persons to the County officers and employees for response.
9. The City agrees to pay the County for the reasonable and ordinary charges to recoup its costs of placement and collection on the tax rolls at the agreed upon rate of 1% of the taxes, assessments, fees and/or charges, as provided by Government Code sections 29304 and 51800.

**THE FOREGOING RESOLUTION WAS DULY AND REGULARLY ADOPTED** at the Regular Meeting of the City Council of the City of Colfax held on the 26<sup>th</sup> day of June 2019 by the following vote of the Council:

**AYES:**

**NOES:**

**ABSTAIN:**

**ABSENT:**

---

**Joe Fatula, Mayor**

**ATTEST:**

---

**Wes Heathcock, City Manager**



# Staff Report to City Council

## FOR THE JUNE 26, 2019 REGULAR CITY COUNCIL MEETING

**From:** Wes Heathcock, City Manager  
**Prepared by:** Amy Feagans, City Planner  
**Subject:** Public Hearing on the Site Plan Review for Lorang Brothers RV and Self-Storage at 1175 S. Auburn Street

*Budget Impact Overview:*

N/A: ✓	Funded:	Un-funded:	Amount:	Fund(s):
--------	---------	------------	---------	----------

**RECOMMENDED ACTION: Conduct a Public Hearing, discuss and consider adopting Resolution 25-2019 approving the Site Plan Review for 1175 S. Auburn Street to develop an RV and Self-Storage Facility.**

### Project Notice

This public hearing has been noticed in accordance with the requirements of California Government Code Title 7, Division 1 “Planning and Land Use” section 65000 et seq., as amended.

### Project Information

**Project Title:** Lorang Brothers RV and Self Storage Site Plan Review  
**Applicant/Owner:** Greg Stedfield, CTA Engineering / Mike Lorang, LBC Properties, LLC  
**Location:** 1175 S. Auburn Street  
**Land Use (existing):**

**Assessor’s Parcel Number:** 100-153-002, -003  
**Zoning District:** I, Industrial  
**General Plan Designation:** Industrial

#### Surrounding Uses/Zoning

**North:** Mink Creek Subdivision/R-MHS  
**South:** Vacant building (former home of Crispin Cider), IND & RM-2  
**East:** S. Auburn Street, Interstate 80  
**West:** County land

### Project Description /Request

The property is located on S. Auburn Street, adjacent to the former Crispin Cider site on the south and backs up to the Mink Creek subdivision on the north. The property is currently used as the construction and storage yard for the Lorang Bros construction operation.

The property owner is requesting approval of a Site Design Review permit to develop the two parcels (2.7 acres and 4.6 acres) as a self-storage and RV storage facility. The proposal is to use used shipping containers for the storage units in lieu of a stick built facility. There are two sizes of containers that will be used - 8' x 20 x 8' (width x length x height) and 8' x 40' x 8'. The RV parking spaces will be 12' x 25' and 12' x 40'. The table below outlines the number quantity and container and parking spaces.

Size	Count
<b>Containers</b>	
8 x 20 x 8'	357
8 x 40 x 8'	14
<b>RV parking</b>	
12' x 25'	10
12' x 40'	7

**Project Analysis**

The site is zoned industrial and self-storage is an allowed use per the zoning ordinance. However, section 17.176 outlines additional requirements for self-storage facilities in any zone. These requirements include excluding certain activities from being permitted (such as living quarters, automotive repair, work shop operations, office use, etc.). There are also additional design requirements including locating the entrance to the facility as far as possible from adjacent residential uses, requiring screening of the facility from adjacent residential uses, and set back outdoor storage a minimum of 20 feet from property lines adjacent to residential. As designed, the setbacks from the Mink Creek subdivision are a minimum of 35 feet to the closest storage unit. The project has been either designed to accommodate these requirements or conditions of approval have been prepared (Exhibit A of the attached resolution) to address them. The hours of operation as outlined in CMC section 17.176.010 are Monday through Friday 7:00 am to 7:00 pm, and on Saturday, Sunday and holidays 8:00 am to 8:00 pm.

The smaller units are approximately the size of a parking stall in footprint and the larger units are twice as long and the RV spaces are standard sizes to accommodate various lengths of RVs. The project will be developed in phases depending on the demand. The container concept should function well as a storage unit and given the location, will not be visible from any public roadway.

The Fire Marshall has reviewed the plans and also conducted a site visit. As a result, he has indicated that the circulation and access as designed meets requirements, that the hydrants will be required on site and the individual container units will either need to be sprinkled or designed with sufficient separation to meet fire code requirements. A condition has been included to address this.

**Environmental Review**

The project has been determined to be exempt from CEQA requirements per section 15332, in-fill development.

**Staff Recommendation**

Staff recommends the City Council adopt the attached resolution approving the site design review of the self-storage facility at 1175 S. Auburn Street.

**Attachments**

1. Resolution 25-2019
2. Location Map
3. Preliminary Site Plan
4. Site Photographs



# City of Colfax

## City Council

### Resolution № 25-2019

---

#### A RESOLUTION OF THE CITY COUNCIL OF THE CITY OF COLFAX APPROVING THE SITE PLAN REVIEW FOR 1175 S. AUBURN STREET TO DEVELOP AN RV AND SELF-STORAGE FACILITY

---

**WHEREAS**, City of Colfax received an application for site plan review to develop a self-storage and RV storage facility at 1175 S. Auburn Street, and

**WHEREAS**, a notice of public hearing has been given at the time and in the manner required by State Law and City Code; and

**WHEREAS**, the project site design as approved provides access, vehicle parking, loading areas, landscaping and irrigation and lighting which results in a safe, efficient, and harmonious development and which is consistent with the applicable goals, policies and objectives set forth in the general plan and the design guidelines established for the I zone district; and

**WHEREAS**, the design of the public services, as approved, are located so as not to detract from the appearance of the site, and are screened appropriately and effectively using construction materials, colors and landscaping that are harmonious with the site and the building designs; and

**WHEREAS**, the project is exempt from CEQA requirements in accordance with section 1221, infill development projects; and

**WHEREAS**, conditions of approval have been prepared and attached to this resolution as Exhibit A; and

**WHEREAS**, the City Council has reviewed and considered the staff report, any and all written comments received during the public review process and any and all oral and written comments submitted at the public hearing; and

**WHEREAS**, the conditions of approval have been prepared for the project as outlined in Exhibit “A” attached to this resolution.

**NOW, THEREFORE, BE IT RESOLVED** by the City Council of the City of Colfax approves the Site Plan Review Permit for Lorang’s Self-Storage project located at 1175 S. Auburn Street.

**THE FOREGOING RESOLUTION WAS DULY AND REGULARLY ADOPTED** at the Regular Meeting of the City Council of the City of Colfax held on the 26<sup>th</sup> day of June 2019 by the following vote of the Council:

**AYES:**

**NOES:**

**ABSTAIN:**

**ABSENT:**

---

**Joe Fatula, Mayor**

**ATTEST:**

---

**Wes Heathcock, City Manager**

**Exhibit A**

## Lorang Brothers Mini Storage - Conditions of Approval

**PLANNING**

1. The project shall be in substantial compliance with the plans and exhibits attached to the staff report dated June 26, 2019.
2. The following uses or activities are prohibited in the self-storage facility:
  - a. Automotive repair which includes, but is not limited to, auto body and paint shop facilities.
  - b. Wood, metal or other working shops whether for business or as a hobby.
  - c. Office and other business uses, except the office for the facility and the storage of personal belongings.
  - d. Living quarters for human habitation or the keeping of animal life, except caretakers/managers quarters.
  - e. Storage of hazardous materials as listed in Title 8, California Code of Regulations, Section 5194 as amended, or its successor section or statute.
    1. Rental agreements shall contain language prohibiting the storage of hazardous materials as outlined above.
    2. The operator of the facility shall maintain a copy of said section and ensure compliance with these regulations.
  - f. Sewer, water or electrical services to any of the storage units except electrical
3. If gated, the facility shall provide gate access/entry at all times for Sheriff, Fire, City inspection utility and other health and safety related vehicles. A gate operating system to provide for emergency vehicle access shall be installed to the satisfaction of the Sheriff and Fire Marshall.
4. Permanent signage shall be approved under a separate Sign Permit. Temporary banners shall only be displayed subject to the provisions of the City's Sign Ordinance regulating promotional events and require approval of a sign Permit.
5. The project plans shall be submitted for review and approval by the Fire Marshall prior to issuance of any City permit.
6. Hours of operation shall be 7:00 am to 7:00 pm Monday through Friday, and 8:00 am to 8:00 pm Saturday, Sunday and holidays.
7. The project shall comply with the requirements of the Colfax Municipal Code section 17.176.040 Self Storage Facilities, as applicable.
8. The applicant shall submit a landscaping plan for the replacement of the dead and dying trees along the Mink Creek property line. The plan shall be approved and the new

landscaping installed prior to the issuance of any permits for the operation of the storage facility.

9. Outdoor storage areas shall maintain a twenty-foot setback from property lines adjacent to residential land uses (Mink Creek).
10. The owner/operator of the outdoor self-storage facility shall maintain in good repair all fencing, walls, lighting, landscaping, driveways and parking areas. The premise shall be kept clean and in an orderly fashion.
11. No truck or vehicle rental shall be conducted from the premises.
12. Flammable or combustible liquids or gasses shall not be used or maintained on site.
13. Wall-mounted lights shall be mounted below the top of the wall and directed downward.

### **ENGINEERING**

14. The applicant shall be responsible for all plan check and inspection costs. The Applicant shall establish a Developer Deposit Account with the City upon the initiation of plan check services.
15. Applicant shall submit site Improvement Plans, prepared by a registered Civil Engineer, for review and approval of the City. No final grading or other construction shall be performed until the Improvement Plans have been approved.
16. All improvements shall be designed in accordance with the City of Colfax Municipal Code, and applicable City, County and Placer County Water Agency (PCWA) public works standards (Public Works Standards).
17. A drainage report prepared by a California Registered Civil Engineer shall be submitted for review with the initial submittal of the Improvement Plans for the entire site, including Phases 1 and 2.
18. Storm-water detention shall be provided per the requirements of the final on-site project drainage analysis and meet local and State drainage requirements. Design of storm water detention facilities shall be subject to City standards and the review and approval of the City Engineer.
19. Any retaining walls necessary as a part of the site grading shall be included on the grading plan for review and approval of the City Engineer. Any retaining walls in excess of 3-ft in exposed height shall have design calculations prepared and submitted to the City Engineer and Building Department for review.
20. Dust control specifications shall be included on the improvement plans to minimize dust nuisance during construction. Dust control measures shall be developed to take into account the possible presence of asbestos bearing rock formations and the measures necessary to deal with this type of dust.

21. For the construction phase, the applicant shall comply with Placer County Air Pollution Control District regulations.
  1. The applicant shall re-vegetate cut and fill areas as soon as possible using native seed mixes and compatible plantings as specified by the City Engineer and the Soil Conservation Service.
22. All public water service laterals or services (domestic water and fire water supply) shall include approved backflow prevention devices.
23. The Applicant shall keep adjoining public streets free and clean of project dirt, mud, materials, and debris during the construction period, as is found necessary by the City Engineer.
24. The developer, at his sole expense, shall repair existing public and private facilities damaged during the course of construction to the satisfaction of the City Engineer.
25. If any hazardous material is encountered during the construction of this project, all work shall be immediately stopped and the Cal Fire, Placer County Department of Environmental Health or other designated agency, and the City Inspector shall be notified immediately. Work shall not proceed until clearance has been issued by all of these agencies.
26. All new fire hydrants shall be securely covered with burlaps sacks or heavy duty plastic until the hydrants have been tested and found to be in conformance with City flow requirements. No storage of combustible materials or construction of building shall be permitted until all hydrants meet City flow requirements.
27. All construction stormwater pollution prevention best management practices (BMP's) shall be installed as the first order of work and in accordance with the *State Water Resources Control Board's General Construction Permit for Stormwater Discharges Associated with Construction and Land Disturbance Activities* and the Applicant's Storm Water Pollution Prevention Plan (SWPPP). All stormwater BMP's shall be maintained to the satisfaction of the Qualified SWPPP Developer (QSD), Qualified SWPPP Practitioner (QSP), and the City Engineer.
28. All construction and grading activities on the site shall be governed by the City's noise ordinance and be limited to between 7:00 a.m. and 7:00 p.m. Monday through Friday and 8:00 a.m. to 7:00 a.m. on Saturday. No work shall be performed on Sunday or state and federal recognized holidays, unless approved by City engineer.
29. Prior to APPROVAL OF THE IMPROVEMENT PLANS, the applicant shall:
  - a. Submit a copy of the Notice of Intent and WDID# for coverage under the State Water Resources Control Board' General Construction Permit for Stormwater Discharges Associated with Construction and Land Disturbance Activities (Order 2009-0009-DWQ).
  - b. Provide the following:
    - 1) Construction Storm Water Pollution Prevention Plan (SWPPP)

2) Drainage Report

30. Prior to COMMENCEMENT OF CONSTRUCTION ACTIVITIES, the Applicant shall:

- a. Pay off all current cash deposit account balances with the City.
- b. Conduct a pre-construction meeting with representatives of the City whereby the Applicant, the Legally Responsible Party (LRP), Qualified SWPPP Practitioner (QSP), Qualified SWPPP Developer (QSD), and/or the Contractor provides the following:
  - (1) Six (6) full-size bond copies of the approved Improvement Plans for the City's use.
  - (2) One (1) job-site copy of the SWPPP for use by the LRP, QSP, QSD, and Contractor.

END OF CONDITIONS



**Mink Creek**

**Former Crispin  
Cider Location**

**I-80**

# LORANG'S RV/MINI STORAGE PRELIMINARY SITE PLAN

CITY OF COLFAX, CALIFORNIA  
SCALE: 1"=40' MARCHEL, 2019

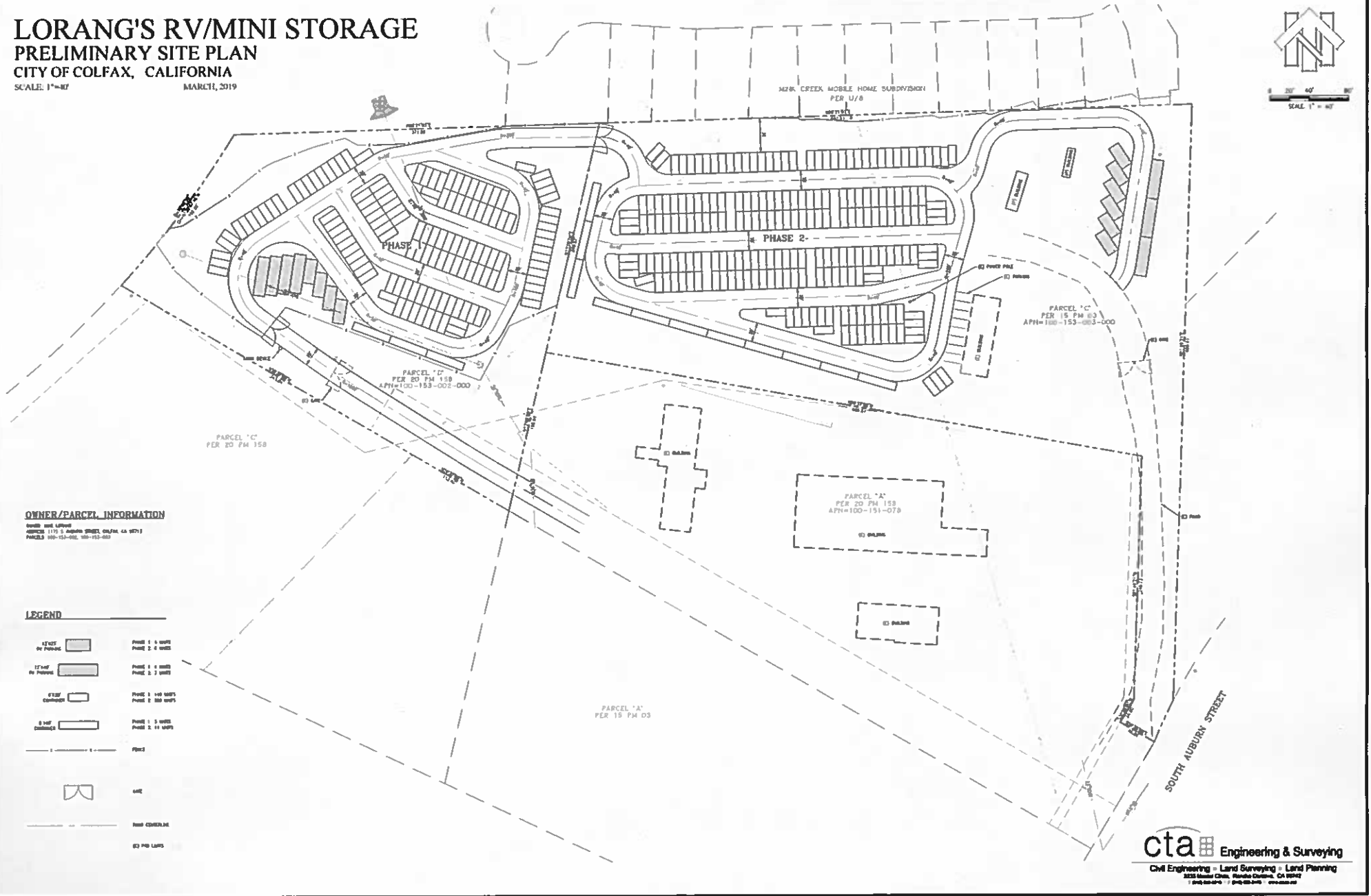



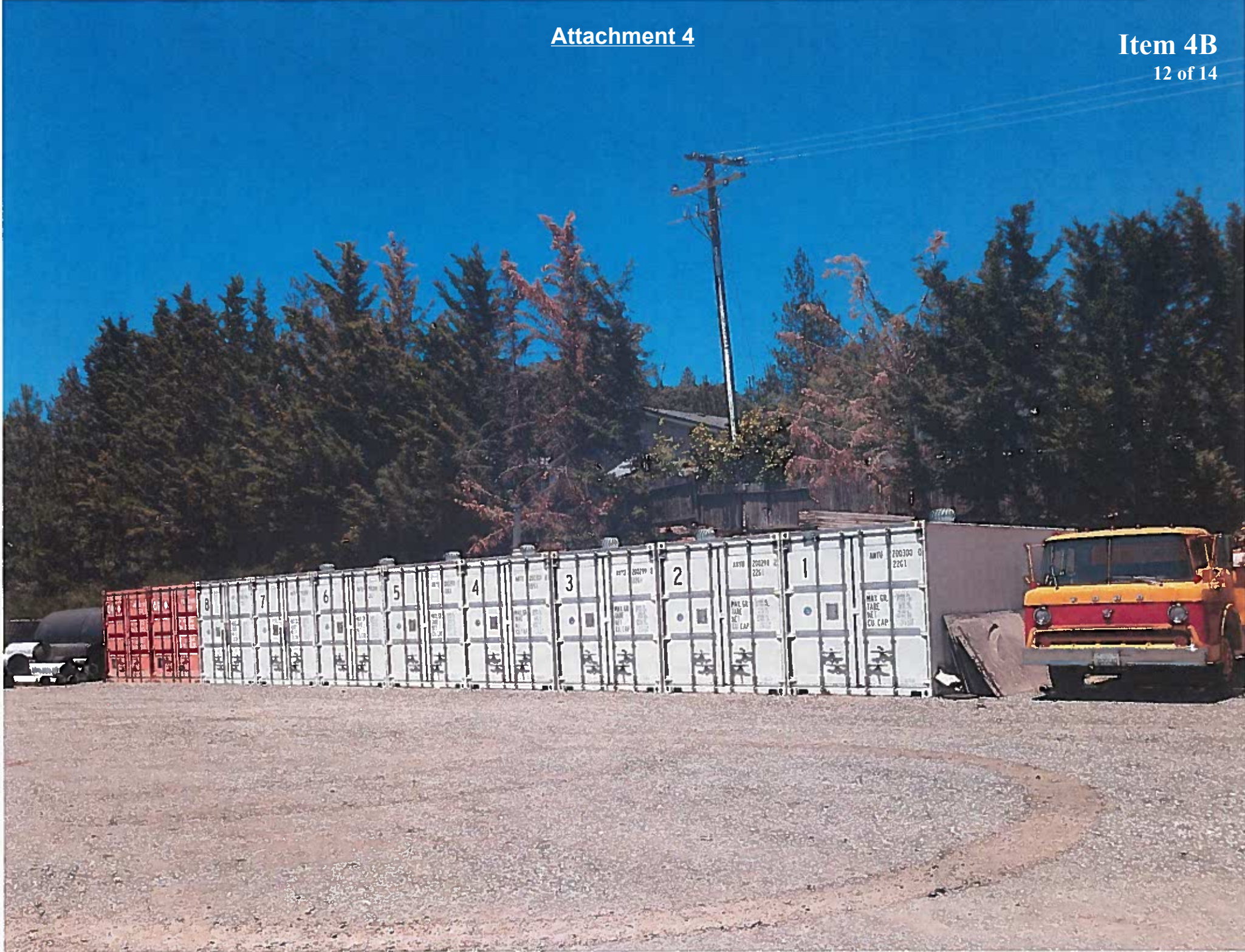

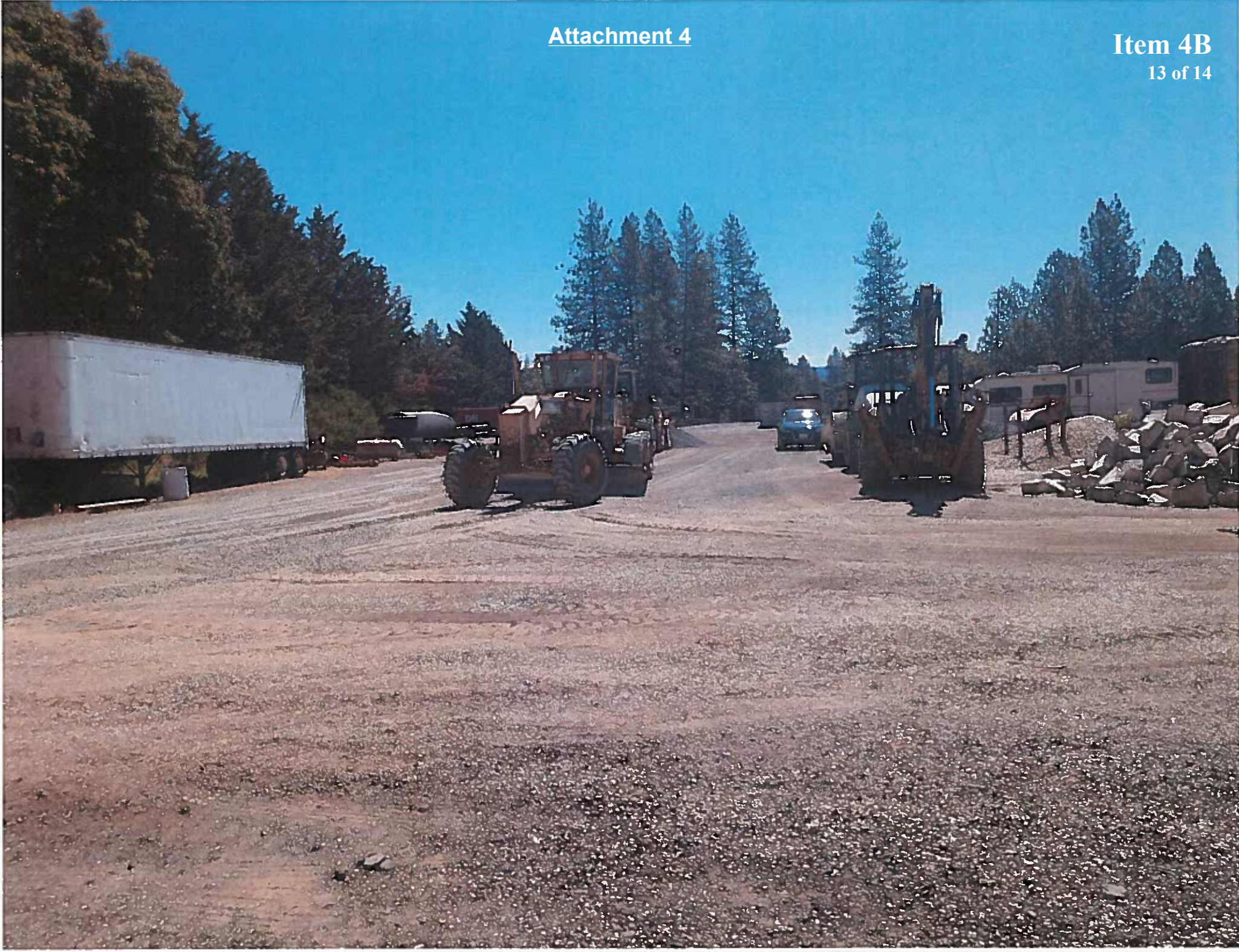

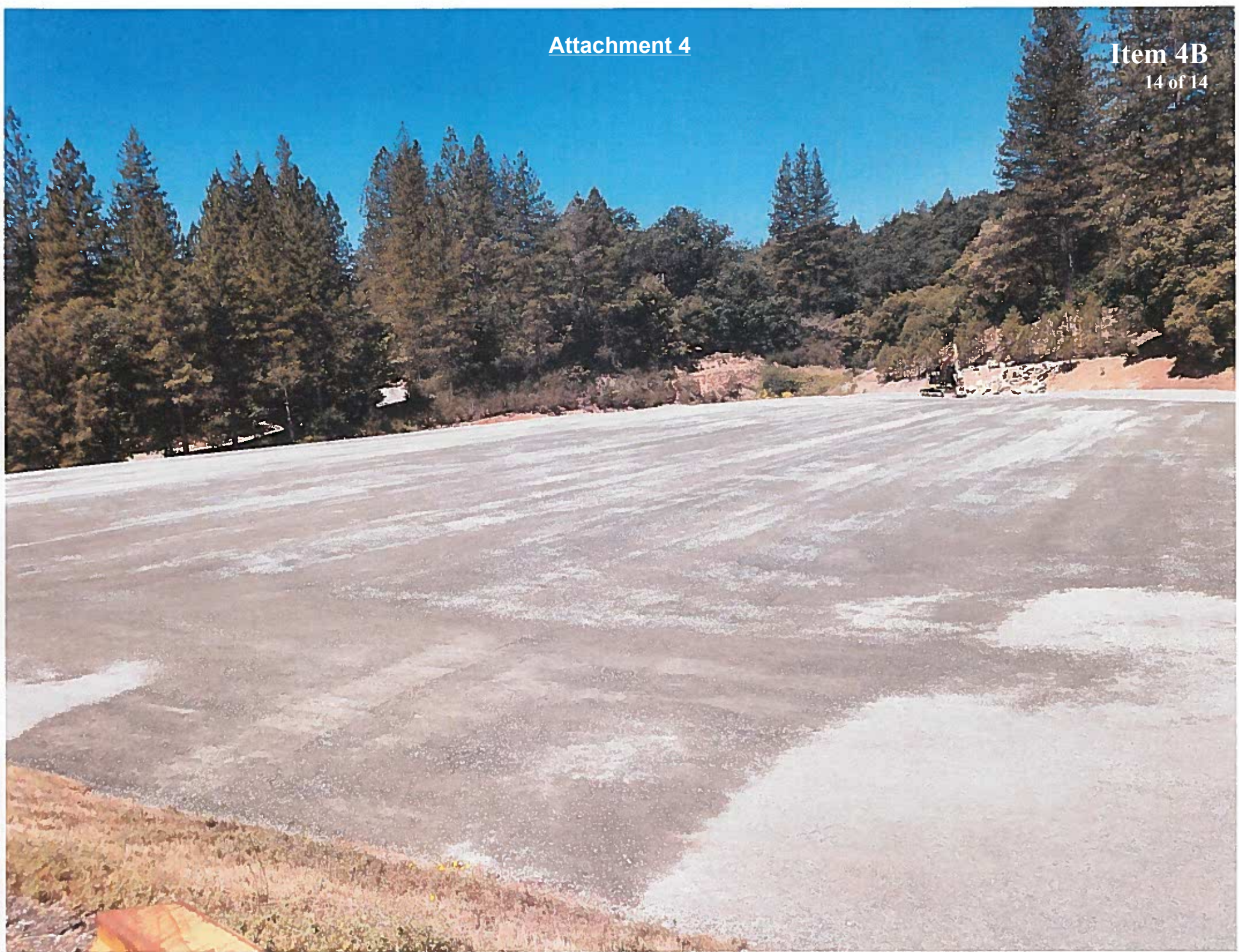



City of Colfax  
 City Council Minutes  
 Regular Meeting of Wednesday, June 12, 2019  
 City Hall Council Chambers  
 33 S. Main Street, Colfax CA

---

## 1 CLOSED SESSION

There was no closed session at this meeting

## 2 OPEN SESSION

### 2A. **Call to Order**

Mayor Fatula called the open session to order at 7:01p.m.

### 2B. **Pledge of Allegiance**

Jared Nicholson, Colfax Falcons, led the Pledge of Allegiance.

### 2C. **Roll Call**

Council members present: Burruss, Fatula, Lomen, Mendoza

### 2D. **Approval of Agenda Order**

On a motion by Councilmember Lomen, seconded by Councilmember Burruss, the City Council approved the agenda order.

**AYES:** Burruss, Fatula, Lomen, Mendoza

## 3 PRESENTATION

3A. Chris Nave introduced the Colfax Falcons and reported that they had gone 14 - 1 in the regular baseball season, and 26-7 overall, and had received nine recognitions. Five or six made "all metro", and Jason Harris was voted the league's most valuable player. Officer Nave praised their work ethic and reported that most of the players had grown up in the same baseball system. Mayor Fatula presented awards to all of the players and coaches present, and the Council and staff congratulated each of them.

## 4 PUBLIC HEARING

### 4A **Public Hearing on the Conditional Use Permit for 1033 S. Auburn Street** **Staff Presentation: Amy Feagans, Planning Director**

**Recommendation:** Conduct a Public Hearing, discuss and consider adopting Resolution 17-2019 approving the Conditional Use Permit for 1033 S. Auburn Street to allow a Single-Family Residence in a CH (Highway Commercial) Zone.

Planning Director Amy Feagans presented the staff report. She explained that the location is a prior charter school that is being converted to a single-family residence. A Conditional Use Permit is required by the Colfax Municipal Code and is necessary to make sure the use fits with the neighborhood and potential problems are mitigated.

Mayor Fatula opened the public hearing at 7:15 p.m. There were no public comments, so the public hearing was closed at 7:15 p.m.

The following issues were addressed in response to Council questions and comments:

1. It is unknown whether the owner will reside in the residence full time.
2. A City permit will be required if the owner plans to use the residence for Air B&B or a similar use. That may be a conditional use permit or an administrative permit depending upon the proposed use.
3. It is not known whether other schools are interested in using the site.
4. A monitoring and enforcement process will be needed if the property is converted to Airbnb or similar use.
5. Staff will assess the need to prepare a City-wide inventory of available Airbnb and similar uses.

On a motion by Council Member Burruss, seconded by Councilmember Lomen, Council present unanimously adopted Resolution 17-2019 approving the Conditional Use Permit for 1033 S. Auburn Street as recommended

**AYES:** Burruss, Fatula, Lomen, Mendoza

**4B Public Hearing on the Ordinance Introduction and Public Hearing on the Planned Development Permit and Design Review for the Shadow Wood Residential Development Project**

**Staff Presentation:** Amy Feagans, Planning Director

**Recommendation:** Conduct a Public Hearing, discuss and consider adopting Resolution 18-2019 approving the Planned Development Permit and Design Review of the Shadow Wood Development Project and Introduce Ordinance No. 539 Amending the Colfax Municipal Code Chapter 16.24 to Allow Amendment or Correction of Final Subdivision Maps (First Reading).

Planning Director Amy Feagans presented the staff report. She explained that the final map for the project was approved in 1978 and recorded in 1980. Although it is not known why the property was not developed earlier, the final map created twenty legally buildable lots on the project site. She also explained that a Planned Development Permit is appropriate and used for larger projects that require flexibility but not a variance. The Planning Director explained the details of the project to the Council and public.

Mayor Fatula opened the public hearing at 7:37 p.m. The following individuals provided comments during the public hearing:

**David Carter:** Mr. Carter is the general contractor on this project and is working with two funding partners. He is trying to develop a project that is affordable for young families and seniors with the least maintenance possible. The homes will include upscale carpeting, wood floors, dimensional roofs. The color palette will be varied such that no two-color schemes will be next to each other and hopefully not across the street from each other. Prices will be in the low-to-mid

\$300,000 range and will be close to the least expensive cost per square foot in Placer County. He wants to help Colfax with a quality development.

Mr. Carter provided the following information in response to questions:

1. The roofs will be fire safe with specific underlayment and solid soffits that will be primed, sealed and painted.
2. The hammerhead turnaround has been replaced by a cul-de-sac as required for fire safety and evacuations.
3. The grading plan adequately addresses slope and grade issues.
4. The street will be offered for dedication to the City.

**Tim Myer.** Mr. Myer is a realtor whose main concerns are water drainage and runoff, and off-street parking. The City Manager said that this development should improve runoff for down-slope properties. The Planning Director confirmed that each lot has two parking spaces, which complies with the applicable codes. The City Manager also mentioned that the developer is required to pave to the center of Kneeland, and the City may pave the rest.

**Joe Gant:** Mr. Gant lives on Grass Valley Street, close to the development. He objected to the density, parking, artificial turf, and small backyards. He is concerned that parking will overflow into Dr. Fox's property.

**Mrs. Gant:** She is concerned about the clutter that will result because the development will have no garages, nowhere for storage and nowhere for kids to play. She is also concerned that there is not adequate sewer capacity, drainage is inadequate, the development is too dense and artificial turf will not work. The City Manager explained the project has adequate sewer and storm water capacity.

**John McLaughlin:** He reported that there is an uphill drainage problem that he believes is the City's responsibility and should be corrected by the City.

**Curtis Fox:** Dr. Fox expressed concern about drainage from the slope, sewer capacity and off-street parking.

**Mary George:** Ms. George questions the adequacy of parking and back alley access. She asked for a construction schedule that excludes building on weekends, or only half-days on Saturday. She also questioned the project density and asked the City to consider something less dense.

**Ann Costa:** She represents the artificial turf vendor and explained its benefits. She said that the entire turf is recyclable like a plastic bottle when it is removed.

Mayor Fatula closed the public hearing at 8:18 p.m. Council had the following questions and comments:

**1. Council Member Lomen:**

Encourages more native landscaping and native plants. The drainage plan is not adequate; the project cannot handle all of the uphill drainage.

**2. Council Member Burruss:**

Confirmed that the setbacks are substandard.

**3. Mayor Pro Tem Mendoza:**

Wanted to know whether homeowners can remove artificial turf.

**4. Mayor Fatula:**

Summarized the comments as (1) the project is too dense; (2) there are drainage issues above and below the project; (3) parking is limited. A study of average cars per home should be conducted so areas for overflow parking can be identified; and (4) sewer capacity. The City Manager confirmed the availability of sewer capacity.

The City Manager said the issue before the Council is the planned development permit and design review. Staff will make sure all capacities are met and will not sign off if they are not. Those issues are handled at the staff level.

Council Member Burruss reiterated that the issue before the Council is the planned development permit and design review. The City Attorney confirmed that the final map was recorded in 1980, and that density was approved long ago and is not before the Council this evening. Downhill drainage has been addressed. Uphill drainage is a separate issue.

The project engineer explained that this project will improve downhill drainage.

On a motion by Council Member Burruss, seconded by Mayor Pro Tem Mendoza, Council present unanimously adopted Resolution 18-2019 approving the Planned Development Permit and Design Review as recommended.

**AYES:** Burruss, Fatula, Lomen, Mendoza

On a motion by Council Member Burruss, seconded by Council Member Lomen, Council present unanimously introduced Ordinance 539 by title only, waived the first reading and put the matter over to the next meeting to consider for adoption.

**AYES:** Burruss, Fatula, Lomen, Mendoza

Mayor Fatula declared a brief recess; the Council reconvened at 8:53 p.m.

**5 CONSENT CALENDAR****5A. Minutes - Regular Meeting May 22, 2019**

**Recommendation:** Approve the Minutes of the Regular Meeting of May 22, 2019.

**5B. Sales Tax Analysis – Quarter Ending March 31, 2019**

**Recommendation:** For information only.

**5C. Fiscal Year 2019-2020 Budget Amendments**

**Recommendation:** Adopt Resolution 19-2019 amending the Fiscal Year 2019-2020 Operating Budget.

**5D. Annual Review of Administrative Policies and Procedures – Financial Policies**

**Recommendation:** Adopt Resolution 20-2019 revising Administrative Policies and Procedures – Financial Policies dated October 8, 2014.

**5E. Cash Summary – May 2019**

**Recommendation:** Accept and file.

Mayor Pro Tem Mendoza pulled Item 5A for discussion. On a motion by Council Member Lomen, seconded by Councilmember Burruss, Council present unanimously approved Consent Calendar items 5B-5E.

**AYES:** Burruss, Fatula, Lomen, Mendoza

Mayor Pro Tem Mendoza asked for a correction to the May 22 minutes. She met Robert Wells, Senior Advisor to Vice President Pence, while in Washington DC, so that reference needs to be moved into her category in the minutes. On a motion by Council Member Lomen, seconded by Councilmember Burruss, Council present unanimously approved Consent Calendar item 5A as amended by Mayor Pro Tem Mendoza.

**AYES:** Burruss, Fatula, Lomen, Mendoza

**6 PUBLIC COMMENT**

There were no public comments at the meeting.

**7 COUNCIL STAFF AND OTHER REPORTS****7A. Committee Reports and Colfax Informational Items – All Councilmembers***Councilmember Lomen*

- Attended the Fire Safe Council. They have a new Facebook page.
- He reported that a website for the Fire Safe Council is being finished.
- There was a food drive on May 25 at which enough money was earned to purchase gear and equipment for training and the fallen fire fighter fund.
- He will work with CalFIRE and PG&E to do fire safety checks.

*Council Member Mendoza*

- Said that blackouts will follow the PG&E wildfires. The City needs to be concerned about seniors. SVCC is a cooling center, but many seniors are home-bound. They need help. Council Member Lomen said there are generators at the fire station. A list of people with medical conditions is being created. Firefighters can legally do welfare checks.



**7B. City Operations – City Staff***City Manager Heathcock*

- City Manager Heathcock reported that roundabout construction is scheduled to begin on June 24. There will be a couple of nights of work. Ground-breaking will occur on July 3 on site at 10:00 a.m. A media release is being prepared.

**7C. Additional Reports – Agency Partners***Tim Ryan*

- Reported that the mixer was well attended and successful, and thanked the Mayor, and Council Members Burruss and Douglass for attending.
- The next mixer is on June 18 at Colfax Mini Storage.
- There will be a climbing wall and dunk tank for July 3rd. Volunteers are being recruited for the dunk tank.
- Presented the new directional sign
- Said the Chamber is preparing new membership forms and information.

*Brian Egan*

- The burn ban goes into effect Monday, June 17th.
- The chipping program is ongoing.
- A defensible space ordinance has been drafted and submitted for review. Council Members Burruss and Lomen are reviewing it.
- Good progress is being made on the American River fuel break and the wastewater treatment site. They are also looking at the Burnt Flat site.
- They will probably do about 300' on Iowa Hill Road
- The Mt. Howell lookout will be staffed June 17th.
- There will be a pre-attack meeting on the evacuation plan tomorrow.

*Ty Conners.*

- Arrests are up; one Deputy was exposed to a meth cloud but will be okay.
- Reported on the successful cigarette theft ring investigation and arrests. He complimented the law enforcement officers involved for a job well done.

*Fred Abbott*

- Parade entry forms for July 3rd are available.
- Lyons car show is scheduled for August 17th.
- Railroad Days are scheduled for September 21st & 22nd.
- Dave and the Cool Beans will have a concert Saturday at 7:00 p.m.
- June 20 is the deadline for the Colfax Connections

*Sharon Conners*

- Attended the Methodist Church spaghetti fund raiser and would like to see more attendance.
- There is a flea market at SVCC this Saturday. It is full of vendors.
- There are yoga classes Sundays at 4:00 p.m.
- The Farmers Market is every Wednesday from 4-7 p.m.
- The community garden is full; no more applications are being accepted.

- They are looking to develop basketball and ping-pong programs.

*Foxy McCleary*

- There is open studio on Tuesdays and Wednesdays from 1-4 in C4 next to the ballpark.
- VFW meets every second Sunday.
- The cruise night and art walk are every 3rd Friday. The next one is June 21st. It costs \$5 per person for two attendances.

## 8 COUNCIL BUSINESS

### 8A. **Sheriff Contract Amendment #4 – Fiscal Year 2019-2020**

**Staff Presentation:** Wes Heathcock, City Manager

**Recommendation:** Discuss and consider adopting Resolution 21-2019 authorizing the City Manager to enter into a contract extension with Placer County Sheriff-Coroner-Marshall's Office with the desired service level option for Fiscal Year 2019/2020.

The City Manager introduced this item and presented two options: Option A will allow the service hours to remain the same as in the past few years, which continues the 196-hour reduction. Option B restores the 196 hours to the contract.

Council Member Burruss supported restoration of the full hours. New development will bring increased revenue to the City to cover the cost and will display commitment to law enforcement. Council Member Lomen emphasized the importance of public safety, noted the increase of response times that result from reduced hours, stated that the absence of a deputy during reduced hours is recognized and it is more important to have a deputy fill the hours and restoring the previously-reduced hours is a responsible way to spend City money. Mayor Fatula confirmed that the contract can be renegotiated if circumstances justify again reducing sheriff hours.

On a motion by Mayor Pro Tem Mendoza, seconded by Councilmember Lomen, Council present unanimously approved the adoption of Resolution 21-2019 authorizing the City Manager to enter into a contract extension with Placer County Sheriff-Coroner-Marshall's Office with Option B that restores all previously-reduced hours, for a cost not to exceed \$736,328.

**AYES:** Burruss, Fatula, Lomen, Mendoza

### 8B. **Sierra Property Development Static Billboard Agreement**

**Staff Presentation:** Wes Heathcock, City Manager

**Recommended Action:** Discuss and consider adopting Resolution 22-2019 authorizing the City Manager to enter into an agreement with Sierra Property Development for a three-year term with the option to extend the term two additional years.

The City Manager introduced this item. He reported that the City owns a billboard that is in need of repair. Staff evaluated the City's options and concluded that the best option for the City is to lease the billboard to a third party. The City has an existing relationship with Sierra Property Development, so they are the preferred lessee. Revenue generated by selling billboard copy will be split 60% to the City and 40% to Sierra Property Development. Gross revenue is expected to range from \$11,500 to \$14,400, to be split accordingly. Bob Townsend, Sierra Property Development representative, supports the contract.

Mayor Fatula asked whether the City has to improve the billboard. The City Manager said the City will pay for improvements, but Sierra Property Development will do them.

Bob Townsend said SPD would like successive five-year terms. The City Manager noted that this contract has a three-year term with one two-year extension. Successive terms can be negotiated as circumstances allow.

Mayor Pro Tem Mendoza asked whether this is the only sign in town that refers to historic Colfax. She wants the freeway sign to say "historic". Mr. Townsend said that the digital billboard gives Colfax eight seconds per cycle in each direction, which he considers to be an incredible opportunity for Colfax. He said the City is gaining momentum and he wants to give people a reason to come back.

The City Manager referred to other signs, including Plaza Tire, the smog shop and McDonalds. The City's branding consultant will help the City upgrade its message and signage.

On a motion by Council Member Lomen, seconded by Council Member Burruss and passed unanimously by the Council present, the Council adopted Resolution 22-2019 authorizing the City Manager to enter into an agreement with Sierra Property Development for a three-year term with the option to extend the term two additional years.

AYES: Burruss, Fatula, Lomen, Mendoza

**9 GOOD OF THE ORDER – INFORMAL COUNCIL STATEMENTS REGARDING THE BUSINESS OF THE CITY**

Mayor Fatula reported on a tour of the Howell Mountain lookout with CalFIRE Battalion Chief Brian Egan, and how to lower the risk of fire, including fire breaks and vegetation management. He showed an eave vent cap that all of the 19 homes that survived the Camp Fire had installed. The cap is round and fits into vent holes. Embers can enter the screen but cannot pass through the cap. He suggested that vendors can be brought to Railroad Days and the possibility of live fire demonstrations.

**10 ADJOURNMENT**

As there was no further business on the agenda, Mayor Fatula adjourned the meeting at 9:35 p.m. Respectfully submitted to City Council this 26th day of June 2019.



Wes Heathcock, City Manager



# Staff Report to City Council

## FOR THE JUNE 26, 2019 REGULAR CITY COUNCIL MEETING

**From:** Wes Heathcock, City Manager  
**Prepared by:** Laurie Van Groningen, Finance Director  
**Subject:** Fiscal Year 2019-2020 Rate Adjustments

*Budget Impact Overview:*

<b>N/A:</b> X	<b>Funded:</b>	<b>Un-funded:</b>	<b>Amount:</b>	<b>Fund(s):</b>
---------------	----------------	-------------------	----------------	-----------------

**RECOMMENDED ACTION:** Information Only

### Summary and Analysis

Effective July 1, 2019 the City will be implementing annual rate adjustments for the following categories:

1. Sewer Impact Fees
2. Monthly Sewer Rates
3. City Salary Schedules
4. CalPERS retirement Employer and Employee contribution rates

### Sewer Impact Fees

New connections to the City of Colfax sewer system are assessed a sewer impact fee (connection fee) in accordance with Municipal Code Chapter 13.08. The Code stipulates that the sewer impact fee shall be adjusted on July 1<sup>st</sup> of each year by the City Engineer by a percentage equal to the annual percentage of increase or decrease in the San Francisco Bay Area construction cost index, as published in the May Engineering News-Record (ENR) or equivalent ENR data.

The City has received the May 2019 ENR data from Coastland Engineering and the construction cost index is reported at a 2.8% increase. The City is applying the increase to calculate the fiscal year 2019-2020 sewer impact fee as reflected in the chart below. Effective July 1, 2019 the sewer impact fee will be adjusted to \$8,950 per Equivalent Dwelling Unit (EDU).

Fiscal Year	Previous	ENR %	New Rate*
2017-2018	\$ 8,370	1.20%	\$ 8,470
2018-2019	\$ 8,470	2.80%	\$ 8,710
2019-2020	\$ 8,710	2.70%	\$ 8,950

*\*Rounded to the nearest ten dollars for simplicity*

**Monthly Sewer Rates**

In June of 2018, the City Council, after due notice, public hearing, and protests heard and received in an open and public meeting adopted and approved the City of Colfax Wastewater Rate Study prepared by Rural Community Assistance Corporation (RCAC) relating to the Sewer Service Charges for Fiscal Years 2018-2019 through 2022-2023. The Sewer Service Charges adopted by Resolution 42-2018 are reflected below. The monthly sewer rate per Equivalent Dwelling Unit (EDU) will be adjusted to \$133.05 monthly (\$266.10 bi-monthly billing) effective July 1, 2019.

# EDU's	Current Monthly Rate	Monthly Rate 2018	Monthly Rate 2019	Monthly Rate 2020	Monthly Rate 2021	Monthly Rate 2022
1.00	\$ 126.76	\$ 129.87	\$ 133.05	\$ 136.31	\$ 139.65	\$ 143.07
1.20	\$ 152.11	\$ 155.84	\$ 159.66	\$ 163.57	\$ 167.58	\$ 171.68
1.30	\$ 164.79	\$ 168.83	\$ 172.96	\$ 177.20	\$ 181.54	\$ 185.99
1.40	\$ 177.46	\$ 181.81	\$ 186.27	\$ 190.83	\$ 195.51	\$ 200.29
1.50	\$ 190.14	\$ 194.80	\$ 199.57	\$ 204.46	\$ 209.47	\$ 214.60
1.60	\$ 202.82	\$ 207.78	\$ 212.88	\$ 218.09	\$ 223.43	\$ 228.91
1.70	\$ 215.49	\$ 220.77	\$ 226.18	\$ 231.72	\$ 237.40	\$ 243.22
1.80	\$ 228.17	\$ 233.76	\$ 239.49	\$ 245.35	\$ 251.36	\$ 257.52
2.00	\$ 253.52	\$ 259.73	\$ 266.09	\$ 272.61	\$ 279.29	\$ 286.14
2.10	\$ 266.20	\$ 272.72	\$ 279.40	\$ 286.24	\$ 293.26	\$ 300.44
2.20	\$ 278.87	\$ 285.70	\$ 292.70	\$ 299.88	\$ 307.22	\$ 314.75

**Salary Schedules**

In accordance with the Memorandum of Understanding between the City of Colfax and I.U.O.E Stationary Engineers, Local 39 (Union), a cost of living adjustment (COLA) is due effective July 1, 2019. The COLA is based on an average of the Consumer Price Index (CPI) for San Francisco-Oakland-San Jose Urban Wage Earners and Clerical Workers and United States City Average Urban Wage Earners and Clerical Workers. The average CPI for the fiscal year 2019-2020 COLA calculation is 2.8%. Consistent with previous years and the adopted operating budget, the City will apply this increase to both represented and non-represented employees salary schedules. The salary schedules for fiscal year 2019-2020 are attached to this report.

**California Public Employees' Retirement System (CalPERS) Retirement**

The CalPERS Actuarial Office provides an annual valuation report each year which contains specific information for the City retirement plans including the development of the current and projected employer and employee contributions. The required normal payroll contributions for fiscal year 2019-2020 are reflected in the following chart.

Fiscal Year	Classic Employees		PEPRA Employees	
	Employer %	Employee %	Employer %	Employee %
2018-2019	8.099%	7.000%	6.842%	6.250%
2019-2020	8.563%	7.000%	6.985%	6.750%

**Attachments**

1. City of Colfax – Salary Range Schedule FY2019-2020 – Represented Employees
2. City of Colfax – Salary Range Schedule FY2019-2020 – Non-Represented Employees

## City of Colfax - Salary Range Schedule FY2019-2020

## Represented Employees

Updated July 01, 2019

CPI Increase 07/01/2019:

2.8%

		Step				
		1	2	3	4	5
Lead Mechanic	Monthly	\$ 4,241.21	\$ 4,454.99	\$ 4,678.31	\$ 4,913.09	\$ 5,157.40
	Hourly	\$ 24.47	\$ 25.70	\$ 26.99	\$ 28.34	\$ 29.75
	Annual	\$ 50,894.53	\$ 53,459.87	\$ 56,139.73	\$ 58,957.02	\$ 61,888.84
Maintenance Worker I	Monthly	\$ 2,928.00	\$ 3,073.06	\$ 3,223.85	\$ 3,388.01	\$ 3,557.88
	Hourly	\$ 16.89	\$ 17.73	\$ 18.60	\$ 19.55	\$ 20.53
	Annual	\$ 35,136.00	\$ 36,876.77	\$ 38,686.25	\$ 40,656.07	\$ 42,694.60
Maintenance Worker II	Monthly	\$ 3,607.51	\$ 3,786.93	\$ 3,975.90	\$ 4,174.40	\$ 4,382.46
	Hourly	\$ 20.81	\$ 21.85	\$ 22.94	\$ 24.08	\$ 25.28
	Annual	\$ 43,290.12	\$ 45,443.18	\$ 47,710.75	\$ 50,092.86	\$ 52,589.48
PW - Working Supervisor	Monthly	4,634.41	4,866.13	5,109.44	5,364.91	5,633.15
	Hourly	\$ 26.74	\$ 28.07	\$ 29.48	\$ 30.95	\$ 32.50
	Annual	55,612.92	58,393.57	61,313.24	64,378.91	67,597.85
Operator in Training	Monthly	\$ 3,309.75	\$ 3,473.90	\$ 3,649.50	\$ 3,828.92	\$ 4,021.71
	Hourly	\$ 19.09	\$ 20.04	\$ 21.05	\$ 22.09	\$ 23.20
	Annual	\$ 39,716.97	\$ 41,686.78	\$ 43,794.03	\$ 45,947.08	\$ 48,260.47
Operator II	Monthly	\$ 4,430.18	\$ 4,651.59	\$ 4,882.55	\$ 5,126.86	\$ 5,380.73
	Hourly	\$ 25.56	\$ 26.84	\$ 28.17	\$ 29.58	\$ 31.04
	Annual	\$ 53,162.10	\$ 55,819.06	\$ 58,590.55	\$ 61,522.36	\$ 64,568.71
Operator II	Monthly	\$ 4,518.78	\$ 4,744.62	\$ 4,980.20	\$ 5,229.40	\$ 5,488.34
<b>GFE Only**</b>	Hourly	\$ 26.07	\$ 27.37	\$ 28.73	\$ 30.17	\$ 31.66
	Annual	\$ 54,225.35	\$ 56,935.44	\$ 59,762.36	\$ 62,752.81	\$ 65,860.08
Operator III	Monthly	\$ 5,002.80	\$ 5,254.75	\$ 5,516.25	\$ 5,791.10	\$ 6,083.14
	Hourly	\$ 28.86	\$ 30.32	\$ 31.82	\$ 33.41	\$ 35.10
	Annual	\$ 60,033.55	\$ 63,056.99	\$ 66,194.95	\$ 69,493.24	\$ 72,997.68
Chief Plant Operator	Monthly	\$ 6,300.74	\$ 6,619.49	\$ 6,951.61	\$ 7,297.10	\$ 7,661.66
	Hourly	\$ 36.35	\$ 38.19	\$ 40.11	\$ 42.10	\$ 44.20
	Annual	\$ 75,608.83	\$ 79,433.94	\$ 83,419.38	\$ 87,565.15	\$ 91,939.98
Administrative Assistant/ Community Development	Monthly	\$ 4,185.86	\$ 4,395.82	\$ 4,615.32	\$ 4,842.46	\$ 5,088.69
	Hourly	\$ 24.15	\$ 25.36	\$ 26.63	\$ 27.94	\$ 29.36
	Annual	\$ 50,230.29	\$ 52,749.82	\$ 55,383.87	\$ 58,109.55	\$ 61,064.27

\*\*GFE (Grandfathered Employee) Only - "Classic" PERS employees only as of January 01, 2017

**City of Colfax - Salary Range Schedule  
Non-Represented Employees  
Updated July 1, 2019**

CPI Increase 07/01/2019: 2.8%

		Step				
		1	2	3	4	5
City Clerk	Monthly	\$ 4,506.52	\$ 4,731.85	\$ 4,968.44	\$ 5,216.87	\$ 5,477.71
	Hourly	<b>\$ 26.00</b>	<b>\$ 27.30</b>	<b>\$ 28.66</b>	<b>\$ 30.10</b>	<b>\$ 31.60</b>
	Annual	\$ 54,078.30	\$ 56,782.21	\$ 59,621.32	\$ 62,602.39	\$ 65,732.51
Accounting Technician	Monthly	\$ 4,185.86	\$ 4,395.15	\$ 4,614.91	\$ 4,845.65	\$ 5,087.94
	Hourly	<b>\$ 24.15</b>	<b>\$ 25.36</b>	<b>\$ 26.62</b>	<b>\$ 27.96</b>	<b>\$ 29.35</b>
	Annual	\$ 50,230.29	\$ 52,741.80	\$ 55,378.89	\$ 58,147.83	\$ 61,055.23
Community Services Director	Monthly	\$ 7,444.07	\$ 7,816.27	\$ 8,207.09	\$ 8,617.44	\$ 9,048.31
	Hourly	<b>\$ 42.95</b>	<b>\$ 45.09</b>	<b>\$ 47.35</b>	<b>\$ 49.72</b>	<b>\$ 52.20</b>
	Annual	\$ 89,328.82	\$ 93,795.27	\$ 98,485.03	\$ 103,409.28	\$ 108,579.74
Customer Service Rep	Monthly	\$ 2,815.38	\$ 2,956.15	\$ 3,103.96	\$ 3,259.16	\$ 3,422.12
	Hourly	<b>\$ 16.24</b>	<b>\$ 17.05</b>	<b>\$ 17.91</b>	<b>\$ 18.80</b>	<b>\$ 19.74</b>
	Annual	\$ 33,784.62	\$ 35,473.85	\$ 37,247.54	\$ 39,109.92	\$ 41,065.42





# Staff Report to City Council

## FOR THE JUNE 26, 2019 REGULAR CITY COUNCIL MEETING

**From:** Wes Heathcock, City Manager  
**Prepared by:** Laurie Van Groningen, Finance Director  
**Subject:** Unfunded Pension Liability

*Budget Impact Overview:*

<b>N/A:</b>	<b>Funded:</b> ✓	<b>Un-funded:</b>	<b>Amount:</b>	<b>Fund(s):</b>
-------------	------------------	-------------------	----------------	-----------------

### RECOMMENDED ACTION: Information Only

#### Summary/Background

Staff completed a comprehensive review of the City's unfunded liability for CalPERS pension obligations which was presented at the January 23, 2019 City Council meeting. A copy of the staff report is attached for background information.

As reported previously, CalPERS implemented the requirement for annual contributions to be made toward the unfunded liability at the beginning of each fiscal year beginning with the fiscal year 2015-2016. The current unfunded balance is amortized over 30 years.

The City has established a General Fund reserve of \$50,000 for Unfunded Pension liability. To date, this reserve has not been utilized; instead rate fluctuations and annual required contributions toward the unfunded liability balance have been budgeted and paid from current operations.

At the January meeting, a request was made for a June 2019 update on some additional options for handling the unfunded liability.

#### 1. Paydown the current Unfunded Liability Balance

##### a. Benefits:

- i. High expected Net Present Value (NPV)
- ii. Elimination of current unfunded liability balance

##### b. Risks:

- i. Reduced freedom to allocate resources in current and future periods
- ii. Does not preclude City from ever having an unfunded liability in future
- iii. Any credit balances would not be returned to City – but would remain with CalPERS for future adjustments.
- iv. Lower NPV if market returns do not meet CalPERS assumed discount rate

2. Adopt Shorter Amortization Schedule – CalPERS allows for election of 15- and 20-year Amortization schedules
  - a. Benefits:
    - i. High expected Net Present Value (NPV)
    - ii. Faster elimination of current unfunded liability balance
  - b. Risks:
    - i. Reduced freedom to allocate resources in current and future periods
    - ii. Does not preclude City from ever having an unfunded liability in future
    - iii. Adoption of shortened amortization schedules is an irrevocable decision.
    - iv. Lower NPV if market returns do not meet CalPERS assumed discount rate
  
3. Make Supplemental Payments
  - a. Benefits:
    - i. City can elect amount of supplemental amounts to be paid
    - ii. Potential for higher expected Net Present Value (NPV)
    - iii. Faster elimination of liability balance
    - iv. No loss of flexibility for future resource allocation
  - b. Risks:
    - i. Does not preclude City from ever having an unfunded liability in future
    - ii. Lower NPV if market returns do not meet CalPERS assumed discount rate

### **Recommendation**

Staff continues to recommend that we do not make any changes at this time and continue to finance the cost of the unfunded liability through the CalPERS required annual contribution. The next Actuarial report is expected in August 2019. We will continue to monitor the City status and review all available options. Staff will pursue a professional actuarial review prior to making any recommendations to change the existing methodology.

### **Attachments**

1. Staff report – Unfunded Pension Liability – January 23, 2019

Attachment 1



# STAFF REPORT TO THE COLFAX CITY COUNCIL

## FOR THE JANUARY 23, 2019 COUNCIL MEETING

**FROM:** Wes Heathcock, City Manager  
**PREPARED BY:** Laurie Van Groningen, Finance Director  
**DATE:** January 16, 2019  
**SUBJECT:** Unfunded Pension Liability

<input checked="" type="checkbox"/>	N/A	<input type="checkbox"/>	FUNDED	<input type="checkbox"/>	UN-FUNDED	AMOUNT:	FROM FUND:
-------------------------------------	-----	--------------------------	--------	--------------------------	-----------	---------	------------

**RECOMMENDED ACTION:** Discuss and direct staff as appropriate

**SUMMARY:**

Unfunded liabilities in public pensions continue to be a hot topic of discussion and the media, particularly concerns over the cost to fund current and future CalPERS pension obligations. An unfunded liability is a disparity between the estimated amount of a pension plan’s obligations and the current value of its assets.

The City of Colfax strives to be proactive in this regard. Staff has reviewed the analysis of our unfunded pension liability which was presented last year and is providing an updated report of the findings and discussion of options available to the City.

**BACKGROUND AND ANALYSIS:**

The City of Colfax provides a defined pension benefit to its eligible employees and participates in the California Public Employees’ Retirement System (CalPERS) to manage and administer the program. Due to our small size of less than 100 employees we are mandated to participate in a miscellaneous risk pool. Risk sharing pools dramatically reduce or eliminate large fluctuations in an employer’s retirement contribution rate caused by unexpected demographic events. In May 2014, the CalPERS Board approved a change to combine all existing pools into two pools, one for all miscellaneous groups and one for all safety groups.

The California Public Employees’ Pension Reform Act (PEPRA) AB340 was passed in 2012, and most of its provisions went into effect January 1, 2013. PEPRA was designed to address a wide range of issues involving public employee pensions and is recognized as a positive step to help agencies better manage future pension costs. The provisions of PEPRA apply only to employees hired after December 31, 2012, who don’t have previous CalPERS service. Some of the changes included in PEPRA include:

1. Reduced defined benefits
2. Increased contributions for employers and employees
3. Delayed retirement ages
4. Eliminated practices that inflate benefits (such as salary spiking)
5. Capped the amount of compensation used to calculate a defined benefit

**Attachment 1**

The City contracted with CalPERS in April of 2008. The City has two benefit formulas/plans, both of which are part of the miscellaneous risk pool:

PLAN	Benefit Formulas	% of City Membership	Employee Contribution	Employer Contribution (current)
Classic Employees	2% at 60	36%	7.00%	8.099%
PEPRA Employees*	2% at 62	64%	6.25%	6.842%

\*PEPRA employees are those hired and are new to CalPERS on or after January 1, 2013.

City employees vest in the program after five years of service. The City makes required employer contributions each pay period as a percentage of employee salaries and an annual payment (dollar amount) towards our unfunded liability.

The City receives an actuarial valuation report from CalPERS each year. This Actuarial report sets forth the assets and accrued liabilities of the City of Colfax plan and determines the required employer contributions for future fiscal years. The report determines City specific minimum employer contributions and annual employer payments toward unfunded liability balances. The most recent report for the City of Colfax – dated August 2018 – provided actuarial valuation data for the City as of June 30, 2017.

The Employer contribution rate is set by the actuarial valuation and is based on assumptions and methods approved by the Board of Administration upon the recommendation of the Chief Actuary. Beginning with FY2015-2016, CalPERS is collecting employer contributions toward the unfunded liability as dollar amounts instead of the prior method of a contribution rate. This amount is invoiced at the beginning of the fiscal year and the plan's normal cost contribution continues to be collected as a percentage of payroll. The unfunded liability portion of the annual contribution is based on paying down the liability over a period of 20 years. In December 2016, the CalPERS Board of Administration lowered the discount rate to be used in actuarial valuations from 7.50 percent to 7.00 percent using a three-year phase-in beginning with the June 30, 2016 valuations.

**ANALYSIS:**

The table below summarizes historical data and projections for the City of Colfax plans compiled from the annual actuarial reports mentioned above and a CalPERS Facts-At-A Glance report for fiscal year 2017-18.

City of Colfax												
Defined Benefit Pension Plan/CalPERS												
CalPERS Actuarial Valuation Report	Employer Normal Contribution Rate (% of regular payroll)			Employer Payment of Unfunded Liability			Estimated Unfunded Accrued Liability				Funded Ratio %	
	FY 2018-19	FY 2019-20	FY 2020-21	FY 2018-19	FY 2019-20	FY 2020-21	6/30/2016	6/30/2017	6/30/2018	6/30/2019	6/30/2016	6/30/2017
Miscellaneous - Classic	8.099%	8.563%	9.200%	\$ 4,293	\$ 6,022	\$ 7,600	\$ 95,811	\$ 92,730	\$ 100,886	\$ 106,544	82.6%	86.2%
Miscellaneous - PEPRA	6.842%	6.985%	7.500%	\$ 614	\$ 1,493	\$ 1,700	\$ 1,527	\$ 989	\$ 4,200	\$ 6,643	91.3%	98.4%
<b>TOTAL CITY</b>				<b>\$ 4,907</b>	<b>\$ 7,515</b>	<b>\$ 9,300</b>	<b>\$ 97,338</b>	<b>\$ 93,719</b>	<b>\$ 105,086</b>	<b>\$ 113,187</b>		
<b>CalPERS - Facts At A Glance (Funded Status Total Public Employees' Retirement Fund)</b>											<b>68%</b>	<b>71%</b>

## Attachment 1

### Highlights:

- The estimated unfunded accrued liability at 06/30/2017 is reported at \$93,719 which is a slight decrease over the previous year.
- The projected increase for the next two years in the employer normal contribution rate and the estimated unfunded accrued liability can generally be attributed to the lowering of the discount rate (being phased in over three years) by CalPERS Board mentioned above.
- As compared to other CalPERS members, the City estimated unfunded liability is very low, primarily due to the following factors:
  - a. Relatively short time in plan (City contracted with CalPERS in 2008)
  - b. Stable and economic benefit formulas. City plans do not include any enhanced benefits which are generally found in plans for public safety (police and fire) personnel.
  - c. High percentage of City staff are in the PEPRA plan.
- The annual employer payment of unfunded liability is less than 10% of normal annual pension contributions and is within annual budget estimated expense.
- The City Funding ratio for both plans is substantially higher than the total Public Employees' Retirement Fund. The fact that the funded ratio % for the Total Public Employees' Retirement Fund could suggest that the PEPRA reforms are making intended improvements.

### Some options for future consideration:

1. The City could pay down the unfunded liability which *could* decrease future liabilities and therefore lower required payments in the future.
  - The amount of savings in future years would depend on actuarial adjustments and actual investment returns of pension assets.
  - A prepayment of the unfunded liability would not preclude the City from ever having an unfunded or overfunded pension liability in the future
  - Current annual payment of unfunded liability is amortized over twenty years and current estimate of interest cost is approximately \$110,000
  - Any prepayments that possibly result in a negative unfunded pension liability would not be returned to the City, but would remain with CalPERS for future adjustments.
2. The City could Increase the reserve for Unfunded Pension Liability. Currently, the City has reserved/committed \$50,000 of fund balance for Unfunded Pension Liability.
3. The City could continue to finance the Cost of the unfunded liability through the CalPERS required annual contribution payments.

The City has made all normal contributions and unfunded liability payments as required.

### **RECOMMENDATION:**

Staff is not recommending any formal action at this time and suggests we continue to finance the cost of the unfunded liability through the CalPERS required annual contribution. As we move forward with our budget reviews and updates, we will insure projections include the latest CalPERS projections.

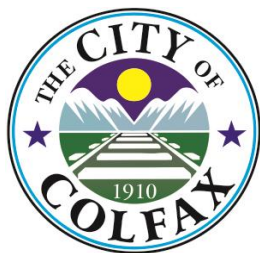

# Staff Report to City Council

## FOR THE JUNE 26, 2019 REGULAR CITY COUNCIL MEETING

**From:** Wes Heathcock, City Manager  
**Prepared by:** Chris J. Clardy, Community Services Director  
**Subject:** Sierra Oaks Sewer Improvements – Notice of Completion

*Budget Impact Overview:*

N/A: ✓	Funded:	Un-funded:	Amount:	Fund(s):
--------	---------	------------	---------	----------

**RECOMMENDED ACTION:** Adopt Resolution 26-2019 accepting the Sierra Oaks Sanitary Sewer Improvement Project as complete and authorizing the recording of the Notice of Completion.

### Summary/Background

On August 9, 2017 the City and Owner entered a Reimbursement Agreement, amended on March 5, 2018 (the “Reimbursement Agreement”) regarding the installation of Sewer Improvements as defined in the Reimbursement agreement.

1. Developer prepared, and City approved subdivision improvement plans for the Sewer. Such improvements are described in detail on plans prepared by RFE Engineering dated March 7, 2018 and approved by the City Engineer on March 8, 2018. The Sewer Improvements provided for and defined in the Reimbursement Agreement are referred to herein as the “Work”.
2. The estimated cost for completing the Work was: \$220,002.00
3. 3.8 of the Reimbursement Agreement require the City to “accept” the improvements, if completed to the satisfaction of the City, and provide a Notice of Completion promptly thereafter.

Final inspection of the project was performed on January 18<sup>th</sup>, 2019. Staff has determined that the work performed by Teichert Construction, for the Sierra Oaks Sewer Improvements, are complete and in accordance with the applicable plans and specifications. 3.10 of the Agreement provides for a one-year guarantee from formal acceptance. With a formal acceptance date of January 18, 2019, the retroactive one-year guarantee ending date will be January 18, 2020.

### Conclusion:

Staff recommends that the City Council accept the Sierra Oaks Sewer Improvements Project as complete, and to authorize the City Clerk to file a Notice of Completion with the Placer County Recorder. The Notice of Completion shall constitute the City’s agreement that the Developer (Sierra Oaks Estates) has completely installed and constructed all of the Sewer Improvements in accordance with applicable plans and specifications, and that the Developer has fulfilled and met all of its obligations hereunder with respect to the installation and construction of the Sewer Improvements.

**Attachments**

1. Resolution 26-2019

# City of Colfax

## City Council

### Resolution № 26-2019

---

#### ACCEPTING THE SIERRA OAKS SANITARY SEWER IMPROVEMENT PROJECT AS COMPLETE AND AUTHORIZING THE RECORDING OF THE NOTICE OF COMPLETION

---

**WHEREAS**, on August 9<sup>th</sup>, 2017 the City of Colfax entered into a Reimbursement Agreement with Sierra Oaks Estates LLC for the Sierra Oaks Sewer Improvement Project; and,

**WHEREAS**, all work with the above agreement was accepted on January 18<sup>th</sup>, 2019, in accordance with the plans and specifications; and,

**WHEREAS**, City Staff recommended to the City Council that said completed project be accepted and a Notice of Completion be filed by the City; and,

**NOW, THEREFORE, BE IT RESOLVED**, by the City Council of the City of Colfax accepting the Sierra Oaks Sewer Improvements Project as complete and authorizing the recording of the notice of completion.

**THE FOREGOING RESOLUTION WAS DULY AND REGULARLY ADOPTED** at the Regular Meeting of the City Council of the City of Colfax held on the 26<sup>th</sup> day of June 2019 by the following vote of the Council:

**AYES:**

**NOES:**

**ABSTAIN:**

**ABSENT:**

---

**Joe Fatula, Mayor**

**ATTEST:**

---

**Wes Heathcock, City Manager**



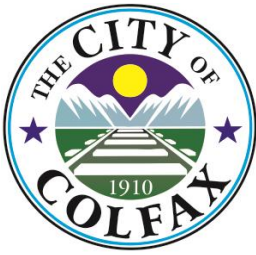

# Staff Report to City Council

## FOR THE JUNE 26, 2019 REGULAR CITY COUNCIL MEETING

**From:** Wes Heathcock, City Manager  
**Prepared by:** Chris J. Clardy, Community Services Director  
**Subject:** Sierra Oaks Estates Subdivision Improvements – Notice of Completion

*Budget Impact Overview:*

N/A: ✓	Funded:	Un-funded:	Amount:	Fund(s):
--------	---------	------------	---------	----------

**RECOMMENDED ACTION:** Adopt Resolution 27-2019 accepting the Sierra Oaks Estates Subdivision Improvements as complete and authorizing the recording of the Notice of Completion.

### Summary/Background

On August 9, 2017 the City and Sierra Oaks Estates LLC entered into a Security Agreement, amended on March 5, 2018 (the “Security Agreement”).

1. Owner prepared, and City approved subdivision improvement plans for the streets, utilities, grading and drainage improvements and facilities to be constructed and installed toward the development of Sierra Oaks Estates. Such improvements are described in detail on plans prepared by RFE Engineering dated March 7, 2018 and approved by the City Engineer on March 8, 2018.
2. The estimated cost for completing the grading, drainage and paving was \$796,237.00.
3. The Colfax Municipal Code and conditions of Subdivision approval and construction require the City to require adequate security to be tendered by the Owner to ensure that the work is diligently pursued and that the work be maintained repaired and guaranteed for a period of one year after it is accepted by the City. The Security was deposited as required and is being held.
4. By the Security Agreement, the City will be allowed to expend the Security as needed to complete, maintain, or repair the work as needed for a period of one year after the work is accepted by the City; and the unexpended portion of the Security will be distributed to the Owner (Eric Stauss) after the one-year guarantee period expires.

Final inspection of the project was performed on June 11th, 2019. Staff and City Engineer has determined that the work performed for the Sierra Oaks Estates Subdivision Improvements are complete and in accordance with the applicable plans and specifications. 3.10 of the Agreement provides for a one-year guarantee from formal acceptance. Formal acceptance will be the date of this resolution, establishing a one-year guarantee end date of June 27<sup>th</sup>, 2020.

**Conclusion:**

Staff recommends that the City Council adopt resolution 27-2019 accepting the Sierra Oaks Estates Subdivision Improvements as complete, and to authorize the City Clerk to file a Notice of Completion with the Placer County Recorder. The Notice of Completion shall constitute the City's agreement that the Owner has completely installed and constructed all of the Subdivision Improvements in accordance with applicable plans and specifications, and that the Owner has fulfilled and met all of its obligations hereunder with respect to the installation and construction of the Subdivision Improvements.

**Attachments**

1. Resolution 27-2019

# City of Colfax

## City Council

### Resolution № 27-2019

---

#### ACCEPTING THE SIERRA OAKS ESTATES SUBDIVISION IMPROVEMENTS AS COMPLETE AND AUTHORIZING THE RECORDING OF THE NOTICE OF COMPLETION

---

**WHEREAS**, on August 9<sup>th</sup>, 2017 the City of Colfax entered into a Security Agreement with Sierra Oaks Estates LLC for the Sierra Oaks Estates Subdivision Improvements; and,

**WHEREAS**, all work with the above agreement was inspected on June 11<sup>th</sup>, 2019 and found to be complete in accordance with the plans and specifications; and,

**WHEREAS**, the Security Agreement provides for a one-year guarantee from formal acceptance that allows the City to expend the Security as needed to complete, maintain, or repair the work; and,

**WHEREAS**, the formal acceptance date will be the date of this resolution, establishing a one-year guarantee end date of June 26, 2020; and

**WHEREAS**, City Staff recommends to the City Council that said completed improvements be accepted and a Notice of Completion be filed by the City.

**NOW, THEREFORE, BE IT RESOLVED** by the City Council of the City of Colfax accepts the Sierra Oaks Estates Subdivision Improvements as complete and authorizing the recording of the notice of completion.

**THE FOREGOING RESOLUTION WAS DULY AND REGULARLY ADOPTED** at the Regular Meeting of the City Council of the City of Colfax held on the 26<sup>th</sup> day of June 2019 by the following vote of the Council:

**AYES:**

**NOES:**

**ABSTAIN:**

**ABSENT:**

---

**Joe Fatula, Mayor**

**ATTEST:**

---

**Wes Heathcock, City Manager**



# Staff Report to City Council

## FOR THE JUNE 26, 2019 REGULAR CITY COUNCIL MEETING

**From:** Wes Heathcock, City Manager  
**Prepared by:** Chris J. Clardy, Community Services Director  
**Subject:** Culver Street Rehabilitation Project - Phase I

*Budget Impact Overview:*

<b>N/A:</b>	<b>Funded:</b> ✓	<b>Un-funded:</b>	<b>Amount:</b> \$220,000	<b>Fund(s):</b> 355
-------------	------------------	-------------------	--------------------------	---------------------

**RECOMMENDED ACTION:** Adopt Resolution 28-2019 accepting the design and specification and authorizing the City Manager to solicit bids for the construction of the Culver Street Rehabilitation Project - Phase I.

### Summary/Background

On May 10, 2017 the City Council adopted resolution 17-2017 authorizing the City Manager to approve a proposal by Coastland Engineering for developing the City's first Pavement Management Plan (PMP). The PMP systematically evaluates the current pavement conditions as well as project future pavement conditions to assist in prioritizing paving projects for all the City's maintained streets.

On May 22, 2018 the City Council adopted the 2018-2019 fiscal year budget which included the projected cost for design and paving of Culver Street from Newman St. to W. Oak Street. The PMP assigned this portion of Culver Street a Pavement Condition Index (PCI) of 9 and 20 placing it in the failed category. The current pavement is 1 inch to 1 ½ inches of asphalt/asphalt patch on top of native soil.

The proposed scope of work for the Culver Street Phase 1 project includes reconstructing approximately 330-linear feet of roadway between Newman Street and W. Oak Street including excavation of failing pavement and subgrade; compacting the subgrade; removing and replacing drainage inlets; adjusting utilities to grade; capping PCWA water main with concrete slurry and pavement reinforcing fabric; and placing new asphalt pavement. Special attention is given to controlling drainage that comes down the westerly hillside and across the road. It is anticipated that construction will occur in August of 2019.

### Budget Impacts

The total project is funded with Community Development Block Grant (CDBG) funds; local streets/road funds; Road Maintenance and Rehabilitation Account (RMRA SB1) funds at the City's discretion. In addition, a reimbursement agreement with Placer County Water Agency (PCWA) will add to the overall project budget, which will be addressed during the award of contract council action.

Staff recommends council accepting the final design and specification and authorize the City Manager to solicit bids for construction.

### Attachments

1. Resolution 28-2019
2. Plans and Specifications

# City of Colfax

## City Council

### Resolution № 28-2019

---

#### ACCEPTING THE DESIGN AND SPECIFICATION AND AUTHORIZING THE CITY MANAGER TO SOLICIT BIDS FOR THE CONSTRUCTION OF THE CULVER STREET REHABILITATION PROJECT - PHASE I

---

**WHEREAS**, the City Council of the City of Colfax adopted resolution 17-2017 authorizing the City Manager to approved the City’s first Pavement Improvement Plan; and,

**WHEREAS**, the City Council of the City of Colfax adopted resolution 32-2018 approving the 2018-2019 fiscal year budget; and the Culver Street Rehabilitation was identified; and

**WHEREAS**, Culver Street’s Pavement Condition Index is in the “failed” category; and

**WHEREAS**, Coastland Engineering, completed plans, specification and engineering and staff is ready to release the project for bidding.

**NOW, THEREFORE, BE IT RESOLVED** by the City Council of the City of Colfax accepting the design and specification and authorizing the City Manager to solicit bids for the construction of the Culver Street Rehabilitation Project - Phase I.

**THE FOREGOING RESOLUTION WAS DULY AND REGULARLY ADOPTED** at the Regular Meeting of the City Council of the City of Colfax held on the 26<sup>th</sup> day of June 2019 by the following vote of the Council:

**AYES:**

**NOES:**

**ABSTAIN:**

**ABSENT:**

---

**Joe Fatula, Mayor**

**ATTEST:**

---

**Wes Heathcock, City Manager**

PROJECT PLANS FOR :  
**CITY OF COLFAX**  
**CULVER STREET PAVEMENT**  
**REHABILITATION PROJECT**

JUNE 2019

CITY OF COLFAX

PLACER COUNTY, CALIFORNIA

FOR USE IN CONJUNCTION WITH:  
 CALTRANS STANDARD SPECIFICATIONS, DATED 2015  
 CALTRANS STANDARD PLANS, DATED 2015

FOR REDUCED PLANS, THE ORIGINAL SCALE IS IN INCHES

3  
2  
1  
0

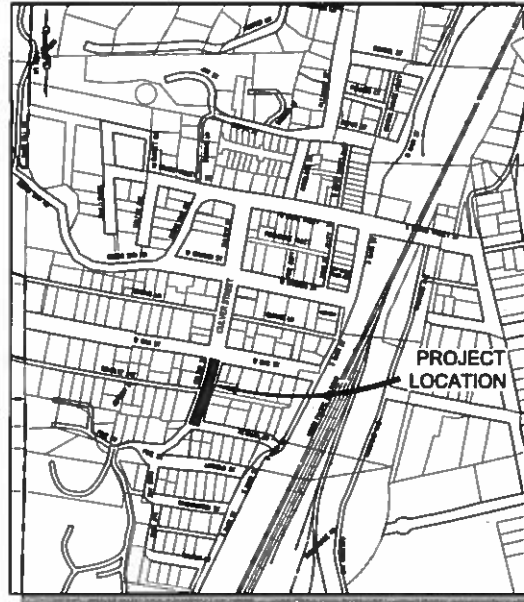
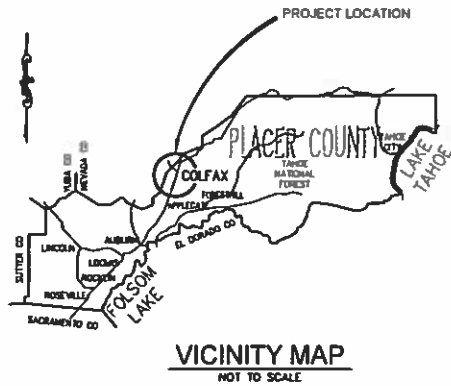

**INDEX OF SHEETS**

No.	Sheet Title
1	TITLE SHEET
2	GENERAL NOTES
3	ABBREVIATIONS, LEGEND & DETAILS
4	SITE PLAN

DATE PLOTTED: 06/19/19 11:58:03 AM PLOTTER: HP DesignJet T1100e



**Coastland Civil Engineering, Inc.**  
 11841 Blocker Dr., Ste 170, Auburn, CA 95803  
 530.888.8820 530.888.8879 Fax

*D.H.S.*  
 DATE 06/19/19



**CITY OF COLFAX**  
 APPROVED  
 DATE 6/20/19  
 [Signature]  
 WES HEARHOOD  
 CITY MANAGER

PROJECT NUMBER	53-3911
DRAWING DATE	JUNE 2019
DRAWING NUMBER	1 of 4

CITY OF COLFAX CULVER STREET PAVEMENT REHABILITATION PROJECT

**GENERAL NOTES:**

1. EXCAVATIONS OVER FIVE FEET (5') DEEP REQUIRE AN EXCAVATION PERMIT FROM THE STATE DEPARTMENT OF INDUSTRIAL SAFETY.
2. CONTRACTOR SHALL CALL "UNDERGROUND SERVICE ALERT" AT (800) 642-2444 AT LEAST ONE (1) WEEK PRIOR TO START OF CONSTRUCTION FOR LOCATING UNDERGROUND UTILITIES.
3. CONSTRUCTION CONTRACTOR AGREES THAT IN ACCORDANCE WITH GENERALLY ACCEPTED CONSTRUCTION PRACTICES, CONSTRUCTION CONTRACTOR WILL BE REQUIRED TO ASSUME SOLE AND COMPLETE RESPONSIBILITY FOR JOB SITE CONDITIONS DURING THE COURSE OF CONSTRUCTION OF THE PROJECT, INCLUDING SAFETY OF ALL PERSONS AND PROPERTY; THAT THIS REQUIREMENT SHALL BE MADE TO APPLY CONTINUOUSLY AND NOT BE LIMITED TO NORMAL WORKING HOURS, AND CONSTRUCTION CONTRACTOR FURTHER AGREES TO DEFEND, INDEMNIFY AND HOLD DESIGN PROFESSIONAL HARMLESS FROM ANY AND ALL LIABILITY, REAL OR ALLEGED, IN CONNECTION WITH THE PERFORMANCE OF WORK ON THIS PROJECT, EXCEPTING LIABILITY ARISING FROM THE SOLE NEGLIGENCE OF THE DESIGN PROFESSIONAL.
4. UNAUTHORIZED CHANGES & USES: THE ENGINEER PREPARING THESE PLANS WILL NOT BE RESPONSIBLE FOR, OR LIABLE FOR, UNAUTHORIZED CHANGES TO OR USES OF THESE PLANS. ALL CHANGES TO THE PLANS MUST BE IN WRITING AND MUST BE APPROVED BY THE PREPARER OF THESE PLANS.
5. NOTICE TO CONTRACTORS: THE EXISTENCE AND LOCATION OF ANY UNDERGROUND UTILITY LINES OR STRUCTURES SHOWN ON THESE PLANS WERE OBTAINED BY A SEARCH OF AVAILABLE RECORDS. TO THE BEST OF THE ENGINEER'S KNOWLEDGE THERE ARE NO EXISTING UTILITIES EXCEPT AS SHOWN ON THESE PLANS. THE CONTRACTOR IS REQUIRED TO TAKE DUE PRECAUTIONARY MEASURES TO PROTECT THE UTILITY LINES SHOWN AND ANY OTHER LINES NOT OF RECORD OR NOT SHOWN ON THESE PLANS.
6. THE CONTRACTOR SHALL BE RESPONSIBLE FOR ANY DAMAGES TO CITY OWNED OR OTHER UTILITIES CAUSED BY HIS OPERATIONS.
7. THE CONTRACTOR SHALL BE RESPONSIBLE FOR OFF-SITE DISPOSAL OF ALL BITUMINOUS PAVEMENT, CONCRETE AND REINFORCEMENT, AND SPOILS NOT NEEDED FOR BACKFILL AS REQUIRED BY THE ENGINEER AND PER THE SPECIFICATIONS.
8. ALL CONSTRUCTION MATERIALS AND METHODS SHALL CONFORM TO THE REQUIREMENTS OF THE CURRENT COUNTY OF PLACER GENERAL SPECIFICATIONS. ALL REFERENCES TO STATE OF CALIFORNIA, DEPARTMENT OF TRANSPORTATION STANDARD SPECIFICATIONS SHALL REFER TO CURRENT EDITION OF THE STANDARD SPECIFICATIONS. ATTENTION IS ALSO DIRECTED TO THE STANDARD PLATES CONTAINED IN THE PLACER COUNTY LAND DEVELOPMENT MANUAL AND THE CURRENT EDITION OF THE CALTRANS STANDARD PLANS, WHICH, WHEN APPLICABLE, ARE INCLUDED IN THESE DRAWINGS AND/OR REFERENCED BY PLATE OR STANDARD PLAN NUMBER. CONTRACTOR IS RESPONSIBLE TO HAVE AVAILABLE A CURRENT SET OF PLACER COUNTY GENERAL SPECIFICATIONS WITH PLATES, CALTRANS STANDARD SPECIFICATIONS, AND CALTRANS STANDARD PLANS.
9. PUBLIC SAFETY AND TRAFFIC CONTROL SHALL BE PROVIDED IN ACCORDANCE WITH COUNTY REQUIREMENTS AND AS DIRECTED BY THE ENGINEER. SAFE VEHICULAR AND PEDESTRIAN ACCESS SHALL BE PROVIDED AT ALL TIMES DURING CONSTRUCTION.
10. CONTRACTOR MUST IMMEDIATELY REINSTALL ANY TRAFFIC SIGNS REMOVED IN THE COURSE OF CONSTRUCTION. ANY SIGNS LOST OR DAMAGED BY THE CONTRACTOR SHALL BE REPLACED OR REPAIRED BY THE CONTRACTOR AS DIRECTED BY THE ENGINEER.
11. THE CITY MAY REQUIRE THE CONTRACTOR TO UNCOVER ANY IMPROVEMENTS THAT HAVE BEEN COMPLETED WITHOUT PROPER CITY INSPECTION AND/OR APPROVAL. IF THE INSTALLATION IS FOUND NOT TO MEET CITY STANDARDS OR PREVIOUSLY APPROVED ALTERNATIVES SHOWN ON THE PLANS, THE CONTRACTOR MAY BE REQUIRED TO REMOVE AND REPLACE SUCH IMPROVEMENTS AT CONTRACTOR EXPENSE.

**GENERAL NOTES (CONTINUED):**

12. PRIOR TO ANY ACTIVITY WITHIN THE CITY RIGHT-OF-WAY, THE CONTRACTOR SHALL INSTALL C19(CA) OR C23(CA) SIGNS IN ACCORDANCE WITH CHAPTER 6 OF THE CURRENT MUTCD MANUAL. THE SIGNS SHALL BE PROFESSIONALLY MADE, METAL, REFLECTORIZED, AND PLACED ON WOODEN POSTS FOR THE DURATION OF THE PROJECT. THE MINIMUM SIZE SHALL BE 36". THE SIGNS SHALL BE REPLACED OR REPAIRED IF STOLEN OR DAMAGED. THE PLACEMENT, TYPE, AND LOCATION OF ALL TRAFFIC CONTROL DEVICES SHALL BE REVIEWED AND APPROVED BY THE ENGINEER. THE ENGINEER OR INSPECTOR SHALL DIRECT THE INSTALLATION OR CHANGES TO SIGNS, STRIPING, CONES, BARRICADES, ETC. DURING THE COURSE OF CONSTRUCTION FOR TRAFFIC SAFETY.
13. IF ANY ARCHEOLOGICAL ARTIFACTS, EXOTIC ROCK (NON-NATIVE), OR UNUSUAL AMOUNTS OF SHELL OR BONE ARE UNCOVERED DURING ANY ON-SITE CONSTRUCTION ACTIVITIES, ALL WORK MUST STOP IMMEDIATELY IN THE AREA AND A SOPA-CERTIFIED (SOCIETY OF PROFESSIONAL ARCHAEOLOGISTS) ARCHAEOLOGIST RETAINED TO EVALUATE THE DEPOSIT. THE CITY PLANNING DEPT. AND THE COUNTY DEPT. OF MUSEUMS MUST ALSO BE CONTACTED FOR REVIEW OF THE ARCHAEOLOGICAL FIND(S). IF THE DISCOVERY CONSISTS OF HUMAN REMAINS, THE PLACER COUNTY CORNER AND NATIVE AMERICAN HERITAGE COMMISSION MUST ALSO BE CONTACTED. WORK IN THE AREA MAY ONLY PROCEED AFTER AUTHORIZATION IS GRANTED BY THE CITY OF COLFAX PLANNING DEPARTMENT. FOLLOWING A REVIEW OF THE NEW FIND AND CONSULTATION WITH APPROPRIATE EXPERTS, IF NECESSARY, THE AUTHORITY TO PROCEED MAY BE ACCOMPANIED BY THE ADDITION OF DEVELOPMENT REQUIREMENTS WHICH PROVIDE PROTECTION OF THE SITE AND/OR ADDITIONAL MITIGATION MEASURES NECESSARY TO ADDRESS THE UNIQUE OR SENSITIVE NATURE OF THE SITE.
14. THE CONTRACTOR SHALL INSURE THAT ALL CONSTRUCTION VEHICLES OR EQUIPMENT, FIXED OR MOBILE, OPERATED WITHIN CLOSE PROXIMITY OF A RESIDENTIAL DWELLING SHALL BE EQUIPPED WITH PROPERLY OPERATING AND MAINTAINED MUFFLERS AT ALL TIMES DURING PROJECT CONSTRUCTION. IT IS THE CONTRACTOR'S RESPONSIBILITY TO OBTAIN THE SERVICES OF A QUALIFIED ACOUSTICAL PROFESSIONAL TO VERIFY PROPER EQUIPMENT MUFFLERS. IF CONCERNS RELATING TO THE ISSUE ARISE. CONSTRUCTION NOISE EMANATING FROM ANY CONSTRUCTION ACTIVITIES FOR WHICH A BUILDING PERMIT OR GRADING PERMIT IS REQUIRED IS PROHIBITED ON SUNDAYS AND FEDERAL HOLIDAYS, AND SHALL ONLY OCCUR:
  - A) MONDAY THROUGH FRIDAY, 7:00 AM TO 7:00 PM
  - B) SATURDAYS, 8:00 AM TO 6:00 PM
15. PRIOR TO THE START OF CONSTRUCTION THE CONTRACTOR SHALL PROVIDE THE CITY OF COLFAX A TRAFFIC PLAN IN ACCORDANCE WITH THE PROJECT SPECIFICATIONS.
16. TEMPORARY TRAFFIC STRIPING MUST BE PROVIDED BY THE CONTRACTOR IF EXISTING DELINEATION IS DESTROYED DURING CONSTRUCTION. PAINTED MARKING OR STRIPING TAPE MAY BE USED. THE TEMPORARY STRIPING MUST BE APPROVED FOR MATERIAL AND LAYOUT BY THE ENGINEER. ALL TEMPORARY PAINTED MARKINGS THAT ARE TO BE REMOVED SHALL BE SANDBLASTED BY THE CONTRACTOR AT THE EXPENSE OF THE CONTRACTOR.
17. ONLY THE APPROXIMATE LOCATION OF THE EXISTING STORM DRAINS & WATER FACILITIES HAVE BEEN SHOWN. THE CONTRACTOR SHALL VERIFY EXACT LOCATION BY POTHOLING IN THE FIELD.
18. IF AT ANY TIME DURING THE COURSE OF CONSTRUCTING THE PROPOSED PROJECT EVIDENCE OF SOIL AND/OR GROUNDWATER CONTAMINATION WITH HAZARDOUS MATERIAL IS ENCOUNTERED, THE APPLICANT SHALL IMMEDIATELY STOP THE PROJECT AND CONTACT ENVIRONMENTAL HEALTH SERVICES HAZARDOUS MATERIAL SECTION. THE PROJECT SHALL REMAIN SUSPENDED UNTIL THERE IS A RESOLUTION OF THE CONTAMINATION PROBLEM TO THE SATISFACTION OF ENVIRONMENTAL HEALTH SERVICES AND TO THE REGIONAL WATER QUALITY CONTROL BOARD.

**PAVING NOTES:**

1. ALL EXISTING AC SURFACES SHALL BE SAWCUT ONE FOOT MINIMUM INSIDE THE EDGE OF PAVEMENT OR AS SHOWING ON THE PLANS TO A HEAT, STRAIGHT LINE AND REMOVED. THE EXPOSED EDGE SHALL BE SEALED WITH EMULSION PRIOR TO PAVING. THE EXPOSED BASE MATERIAL SHALL BE GRADED, RECOMPACTED, AND RESEALED PRIOR TO PAVING.
2. ASPHALT CONCRETE SHALL BE TYPE A, 1/2" MAXIMUM MEDIUM GRADING AND SHALL CONFORM TO THE SPECIAL PROVISIONS.
3. AGGREGATE BASE SHALL BE CLASS 2, 3/4" MAXIMUM GRADING. AGGREGATE BASE SHALL CONFORM TO THE SPECIAL PROVISIONS.

**FUGITIVE DUST CONTROL:**

1. THE CONTRACTOR IS TO MAINTAIN ADEQUATE DUST CONTROL PER SECTION 10, CALTRANS SPECIFICATIONS, AND UTILIZE DUST CONTROL MITIGATION APPROVED BY THE AIR POLLUTION CONTROL DISTRICT (A.P.C.D.). PARTICULATE CONTROL MEASURES SHALL ALSO BE USED THROUGHOUT THE CONSTRUCTION PHASE OF THIS PROJECT.
2. THE CONTRACTOR SHALL FOLLOW THE GUIDELINES OUTLINED IN THE "FUGITIVE DUST CONTROL" HANDBOOK AVAILABLE FROM A.P.C.D.
3. THE CONTRACTOR SHALL APPLY WATER TO ALL DISTURBED AREAS FOR THE ALLEVIATION OR PREVENTION OF DUST NUISANCE.
4. DUST PRODUCING CONSTRUCTION ACTIVITIES SHALL BE SUSPENDED DURING PERIODS OF HIGH WINDS (GUSTS EXCEEDING 25 MPH).
5. CONSTRUCTION VEHICLES AND EQUIPMENT SHALL BE RESTRICTED TO TRAVEL ALONG WELL WATERED CONSTRUCTION ROUTES AND SHALL BE LIMITED TO A MAXIMUM SPEED OF 15 MPH ON NON-PAVED CONSTRUCTION SITES.
6. THE CONTRACTOR SHALL USE TARPAULINS OR OTHER EFFECTIVE COVERS FOR HAUL TRUCKS WHICH TRAVELS IN PUBLIC STREETS.
7. EXISTING STREETS AND PAVED ROADS SHALL BE REGULARLY SWEEP AS FAR AS NECESSARY TO ENSURE THAT NOT SILT, DEBRIS OR POLLUTANT ARE CARRIED OVER TO ADJACENT PUBLIC THOROUGHFARES. DO NOT WASH DOWN STREETS WITH WATER UNTIL DIRT AND DUST HAS BEEN REMOVED BY DRY SWEEPING. THIS IS TO PREVENT CONTAMINATION OF WATERWAY WITH SEDIMENT.
8. ALL CONSTRUCTION EQUIPMENT SHALL BE CLEANED REGULARLY AND KEPT PROPERLY TUNED TO MINIMIZE THE AMOUNT OF DUST AND POLLUTANTS EMITTED INTO THE AIR.

**WATER NOTES:**

1. THE CONTRACTOR SHALL PROVIDE TWO WORKING DAYS NOTICE TO PLACER COUNTY WATER AGENCY INSPECTION HOTLINE AT (530) 823-4885 PRIOR TO BEGINNING ANY WORK OVER WATER MAIN FACILITIES.



PREPARED UNDER THE DIRECTION OF  
 DATE: 06/10/19  
 DRAWN BY: D.H.S.  
 CHECKED BY: [Signature]  
 IN CHARGE: [Signature]  
 SCALE: AS SHOWN  
 SHEET NO.: 2 OF 4

**Coscofield Civil Engineering, Inc.**  
 11641 Rockledge Dr., Ste. 1700, Colfax, CA 95705  
 (530) 823-4885

CITY OF COLFAX  
 CALIFORNIA  
 CULVER STREET PAVEMENT REHABILITATION PROJECT  
**GENERAL NOTES**

PROJECT NUMBER: 53-3011  
 DRAWING DATE: JUNE 2019  
 SHEET NUMBER: 2 OF 4

ABBREVIATIONS

AC	ASPHALT CONCRETE	MS	MANHOLE
AB	AGGREGATE BASE	MO	MANHOLE
AVV	AIR RELEASE VALVE	OG	ORIGINAL GROUND
BO	BLOWOFF	OH	OVERHEAD UTILITY
C	CENTERLINE	PO	PULL BOX
CB	CATCH BASIN	POC	POINT OF COMPOUND CURVE
CI	CLASS INLET	PCWA	PLACER COUNTY WATER AGENCY
CPP	CAST-IN-PLACE PIPE	PH	UTILITY POHOLE
CL	CLASS	PVC	POLY VINYL CHLORIDE
CO	CLEAROUT	R	RADIUS
COAC	CONCRETE	RCP	REINFORCED CONCRETE PIPE
CSP	CONCRETE STEEL PIPE	RET	RETAINING
CV	CHECK VALVE	RFB	REDUCED PRESSURE BACKFLOW PREVENTER
DI	DROP INLET	RW	RECLAIMED WATER
DIP	DUCTILE IRON PIPE	R/W	RIGHT-OF-WAY
DWT	DWY	S	SLOPE
E	ELECTRICAL CONDUIT	SD	STORM DRAIN
EP	EDGE OF PAVEMENT	SL	STREET LIGHT
ESMT	EASEMENT	SS	SANITARY SEWER
ETW	EDGE OF TRAVELED WAY	STA	STATION
EXIST, EX	EXISTING	STD	STANDARD
F	FLOWLINE	TD	TOP OF DRAIN
FG	FISHED GRADE	TC	TOP OF CURB
FH	FIRE HYDRANT	TEL	TELEPHONE
FC	FACE OF CURB	TO	TOP OF GRADE
FX	FENCE	TSE	TOP OF SLOPE
G	GAS MAIN	TP	TELEPHONE POLE
GV	GATE VALVE	TR	TOP OF RAIL
HDPE	HIGH DENSITY POLYETHYLENE	TP	TYPICAL
INVT	INVERT	U	UNDERGROUND UTILITY
IP	IRON PIPE	UTL	UTILITY
JP	JOINT POLE	VF	VERIFY IN FIELD
JT	JOINT UTILITY TRENCH	W	WATER, WATER MAIN
LAT	SANITARY SEWER LATERAL	WM	WATER METER
LF	LINEAL FEET	WME	WATER MAIN EASEMENT
		WV	WATER VALVE

LEGEND

DESCRIPTION OF LINE/TYPE	PROPOSED	EXISTING
CENTER LINE/ CONTROL LINE	N/A	---
WATER MAIN PIPE	N/A	— —
SANITARY SEWER PIPE	N/A	— —
STORM DRAIN PIPE	N/A	— —
TELEPHONE LINE/CONDUIT	N/A	— —
ELECTRICAL LINE/CONDUIT	N/A	— —
OVERHEAD UTILITY	N/A	— —

DESCRIPTION OF SYMBOL	PROPOSED	EXISTING
CONCRETE	▒	▒
ASPHALT CONCRETE	▒	▒
SANITARY SEWER MANHOLE	N/A	⊙
STORM DRAIN MANHOLE	N/A	⊙
STORM DRAIN INLET	⊙	⊙
WATER METER	⊙	⊙
WATER MAIN GATE VALVE	N/A	⊙

CONSTRUCTION NOTE DESIGNATIONS

- (R1) - DRAINAGE AND RELATED ITEMS CONSTRUCTION NOTES.
- (R2) - ROADWAY AND RELATED ITEMS CONSTRUCTION NOTES.
- (R3) - WATER AND RELATED ITEMS CONSTRUCTION NOTES.

DETAIL AND SECTION CALLOUTS

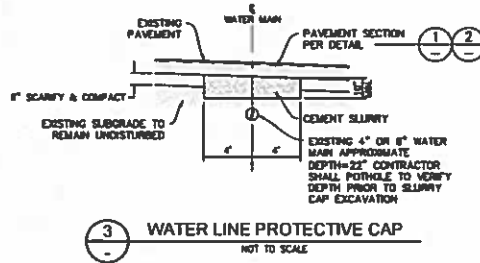
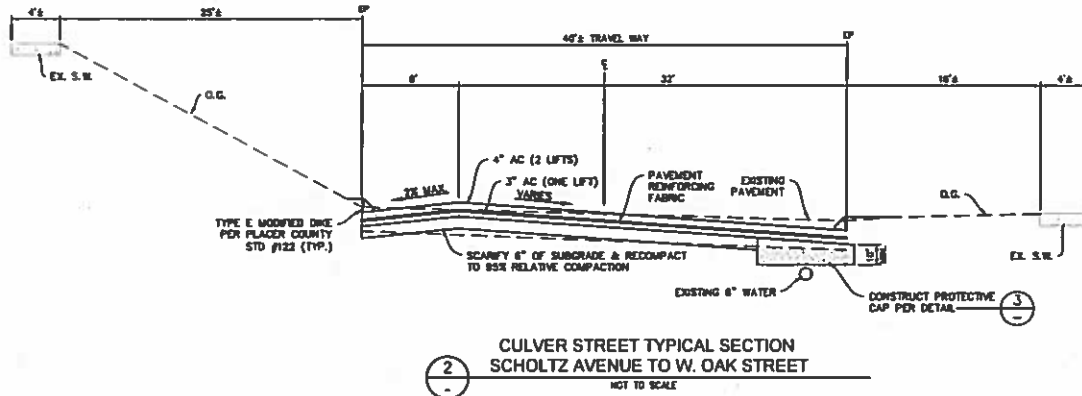
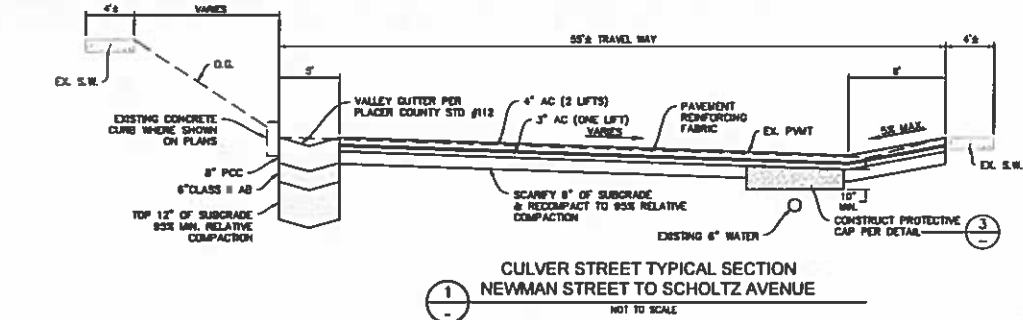
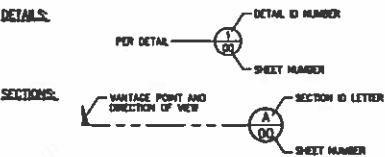

PREPARED UNDER THE DIRECTION OF  
 DATE: 06/11/19  
 DRAWN BY: D.H. Soper  
 CHECKED BY: D.H. Soper  
 IN CHARGE: D.H. Soper  
 PROJECT NO.: 53-3011  
 SHEET NO.: 3 OF 4

**Constard Civil Engineering, Inc.**  
 11541 Blinnway Dr., Ste. 170, Auburn, CA 95603  
 (530) 885-1111  
 Constard Civil Engineering, Inc. is an Equal Opportunity Employer.

CITY OF COLIFAX CALIFORNIA  
 CITY OF COLIFAX  
 CULVER STREET PAVEMENT REHABILITATION PROJECT  
**ABBREVIATIONS, LEGEND & DETAILS**

PROJECT NUMBER: 53-3011  
 DRAWING DATE: JUNE 2019  
 SHEET NUMBER: 3 OF 4

FOR REDUCED PLANS, THE ORIGINAL SCALE IS IN INCHES  
 1" = 10' (VERTICAL SCALE)  
 1" = 40' (HORIZONTAL SCALE)  
 DATE: 06/11/19  
 DRAWN BY: D.H. Soper  
 CHECKED BY: D.H. Soper  
 IN CHARGE: D.H. Soper  
 PROJECT NO.: 53-3011  
 SHEET NO.: 3 OF 4



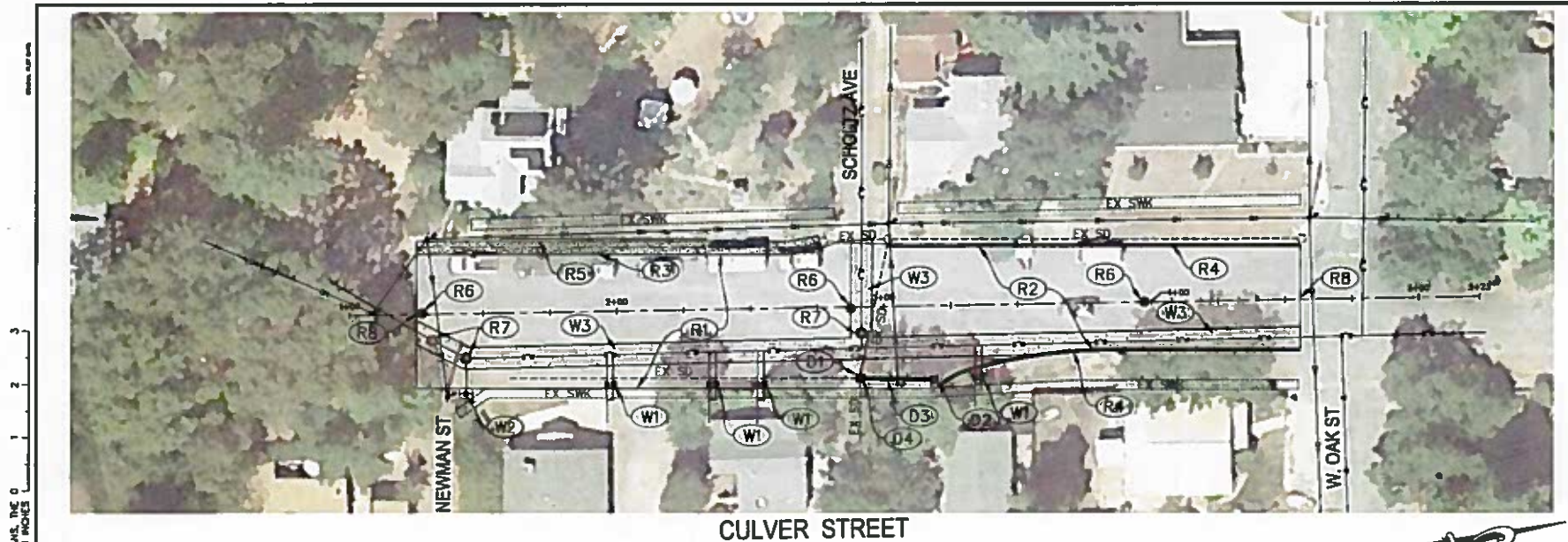

PREPARED UNDER THE DIRECTION OF  
*D.H.S.*  
DATE: 06/15/19  
DRAWN BY: J.D.  
CHECKED BY: C.D./J.M.  
REVIEWED BY: P.M.

**Coastland Civil Engineering, Inc.**  
11845 Woodgate Dr. Ste 1752, Culver City, CA 90230  
310.308.8770 Fax 310.308.8770

CITY OF COLIFAX  
CULVER STREET PAVEMENT REHABILITATION PROJECT  
**CULVER STREET SITE PLAN**

FOR REDUCED PLANS, THE ORIGINAL SCALE IS IN INCHES

PROJECT NUMBER: 53-3011  
DRAWING DATE: JUNE 2019  
SHEET NUMBER: 4 OF 4

**CONSTRUCTION NOTES**

- (D1) REMOVE EXISTING INLET AND REPLACE WITH 24" X 24" PRECAST DRAINAGE INLET PER THE SPECIFICATIONS. TOP OF GRATE TO BE SET TO NEW AC FLOWLINE. INSPECTOR TO VERIFY PROPOSED LINES & GRADES.
- (D2) REMOVE EXISTING INLET AND REPLACE WITH 18" X 18" PRECAST DRAINAGE INLET PER THE SPECIFICATIONS. TOP OF GRATE TO BE SET TO NEW AC FLOWLINE.
- (D3) REMOVE EXISTING SD PIPE AND INSTALL 12" SD PIPE, 30 LF S=0.005.
- (D4) INSTALL NEW 12" SD TO MATCH INVERT OF EXISTING OUTLET.
- (R1) CONSTRUCT PAVEMENT REHABILITATION PER DETAIL 

1	3
---	---
- (R2) CONSTRUCT PAVEMENT REHABILITATION PER DETAIL 

2	3
---	---
- (R3) CONSTRUCT CONCRETE VALLEY GUTTER PER PLACER COUNTY STD 112
- (R4) CONSTRUCT TYPE E MODIFIED ASPHALT DIKE PER PLACER COUNTY STD 122
- (R5) EXISTING CONCRETE CURB, PROTECT IN PLACE.
- (R6) ADJUST MANHOLE FRAME AND COVER TO FINISH GRADE
- (R7) ADJUST WATER VALVE FRAME AND COVER TO FINISH GRADE
- (RB) CONFORM TO EXISTING PAVEMENT.
- (W1) NEW WATER SERVICE METER AND BOX BY OTHERS.
- (W2) FIRE HYDRANT AND VALVE ASSEMBLY BY OTHERS.
- (W3) CONTRACTOR SHALL PROTECT EXISTING ASBESTOS CEMENT WATER MAIN IN PLACE AND CONSTRUCT WATER LINE PROTECTIVE CAP PER DETAIL 

3	3
---	---

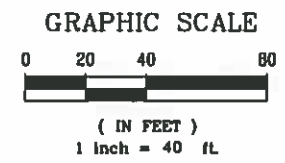

Sheet 4 of 4. Project 53-3011 - Culver Street Pavement Rehabilitation Project. Prepared by J.D. on 06/15/19. Checked by C.D./J.M. on 06/15/19. Reviewed by P.M. on 06/15/19. Date of Issue: 06/15/19. Scale: As Shown.

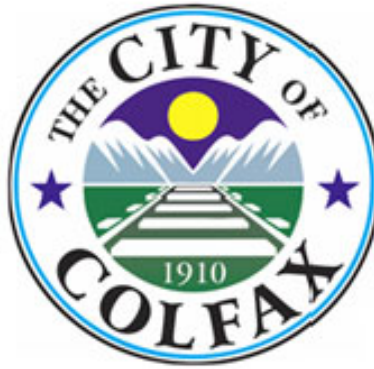

CITY OF COLFAX  
CALIFORNIA

NOTICE TO CONTRACTORS

SPECIAL PROVISIONS, PROPOSAL AND CONTRACT

FOR

**CULVER STREET PAVEMENT REHABILITATION PROJECT**

A COMMUNITY DEVELOPMENT BLOCK GRANT (CDBG) GRANT PROJECT NO. \_\_\_\_\_

FOR USE IN CONNECTION WITH  
STANDARD SPECIFICATIONS AND STANDARD PLANS DATED 2015  
OF THE CALIFORNIA DEPARTMENT OF TRANSPORTATION

AND

CURRENT GENERAL PREVAILING WAGE RATES AND  
LABOR SURCHARGE AND EQUIPMENT RENTAL RATES  
OF THE CALIFORNIA DEPARTMENT OF TRANSPORTATION

BID OPENING DATE:

**2:30 p.m., July 25, 2019**

**CITY OF COLFAX  
PUBLIC WORKS DEPARTMENT  
33 SOUTH MAIN STREET  
P.O. BOX 702  
COLFAX, CA 95713**

**NOTICE INVITING BIDS**

NOTICE IS HEREBY GIVEN that sealed bids will be received by the Office of the City Clerk of the City of Colfax, 33 South Main Street, P.O. Box 702 Colfax, California 95713, until the hour of **2:00 p.m., on the 25<sup>th</sup> of July, 2019** at which time they will be publicly opened and read for the construction in accordance with the project plans and specifications for the following public works project:

**CULVER STREET PAVEMENT REHABILITATION PROJECT**

Complete bid packages, including project plans, technical specifications, bid forms and contract documents may be secured at the office of:

City of Colfax  
Office of the City Clerk  
33 South Main Street  
P.O. Box 702  
Colfax, California 95713  
phone (530) 346-2313, fax (530) 346-6214

at the following non-refundable costs: **Specifications and Contract Documents \$30.00 per set. If mailing is desired an additional non-refundable cost of \$5.00 per set will be required.** Checks shall be made payable to "City of Colfax".

The Engineer's Estimate of probable construction cost of the project is \$225,000.

**Attention is directed to Section 10-1.10 Obstructions regarding adjustment of water valves and coordination with Placer County Water Agency (PCWA).**

In accordance with California Public Contract Code Section 3400, bidders may propose equals of products listed in the technical specifications or project plans by manufacturer name, brand or model number, unless the technical specifications or plans specify that the product is necessary to match others in use. Complete information for products proposed as equals must be submitted in writing to the City Engineer for review at least 10 working days before the time specified for bid opening in accordance with the bidders instructions contained in the bid package.

In accordance with California Public Contract Code Section 20170, all bids must be presented under sealed cover and include one of the following forms of bidder's security: cash, cashier's check made payable to the City, certified check made payable to the City, or a bidder's bond. The amount of bidder's security provided must equal at least ten (10) percent of the total of the bid price for the base bid and the additive or deductive items listed in this notice. The successful bidder must submit to the City complete, executed copies of all required documents within ten (10) working days of date of written notice of award of the project. Bidder's security of any successful bidder that fails to do so will be forfeited to the City.

Such required documents include, but are not limited to, a payment or labor and materials bond in an amount of at least 100 percent of the amount payable by the terms of the project contract and that satisfies the requirements of California Civil Code Section 9554, and a performance bond in an amount of at least 100 percent of the amount payable by the terms of the contract. All project bonds must be executed by an admitted surety insurer in accordance with applicable law and acceptable to the City.

Pursuant to the provisions of Section 1770 et seq. of the California Labor Code the Director of Industrial Relations for the State of California has ascertained the current general prevailing rate of wages for employer purposes, in Placer County, State of California. Not less than the general prevailing rate of per diem wages for work of a similar character in Placer County and not less than the general prevailing rate of per diem wages for holiday work fixed as provided in the California Labor Code shall be paid to all workers engaged in performing the project.

*The City of Colfax has obtained from the Placer County Housing and Community Development Department, the Federal Wage Decision listing the general prevailing wages and fringes in the County in which said work is to be performed for each craft and type of worker or mechanic needed to execute the contract. A copy of the Federal Wage Decision is included in the bid documents. The successful Contractor shall post said prevailing wage rates in a prominent place at the job site. If there is a discrepancy or difference between the state prevailing wage rate and the federal prevailing wage rate, the higher rate will apply.*

Pursuant to the provisions of Section 1771.1 of the California Labor Code, a contractor or subcontractor shall not be qualified to bid on, be listed in a bid proposal, subject to the requirements of Section 4104 of the Public Contract Code, or engage in the performance of any contract for public work, as defined in Chapter 1 of Part 7 of Division 2 of the California Labor Code, unless currently registered and qualified to perform public work pursuant to Civil Code Section 1725.5. **Please note:** *It is not a violation of Section 1771.1 for an unregistered contractor to submit a bid that is authorized by Section 7029.1 of the Business and Professions Code or by Section 10164 or 20103.5 of the Public Contract Code, provided the contractor is registered to perform public work pursuant to Section 1725.5 at the time the contract is awarded.* Any bids submitted without proof that Bidder and any listed subcontractor(s) are currently registered and qualified to perform public work, pursuant to Labor Code Section 1725.5, shall not be accepted by the City.

In accordance with the California Government Code Section 1773.2, copies of the applicable determinations of the Director are on file in the City of Colfax, City Clerk, and may be reviewed upon request.

A pre-bid meeting is not scheduled for this project.

In accordance with California Civil Code Section 1771.4, the project is subject to compliance monitoring and enforcement by the Department of Industrial Relations.

In accordance with California Public Contract Code Section 3300, a valid Class A California contractor's license is required at the time the contract is awarded.

In accordance with California Public Contract Code Section 22300, except where prohibited by federal regulations or policies, the successful bidder may, on request and at its expense, substitute securities in lieu of amounts withheld by the City from progress payments to ensure performance under the contract in accordance with the contract documents.

The City of Colfax reserves the right to postpone the date and time for the opening of proposals at any time prior to the date and time announced in the advertisement in accordance with applicable law.

The City of Colfax reserves the right to reject any and all bids or to waive any defects or irregularity in bidding in accordance with applicable law. In accordance with California Public Contract Code Section 20103.8, if the City elects to award a contract for performance of the project, the contract will be awarded in accordance with California Public Contract Code Section 20162 and other applicable law to the responsible bidder submitting a responsive bid with the lowest total bid price for the base bid without consideration of the bid price for any additive or deductive items. The lowest responsive bidder and any listed subcontractors will be checked to ensure that they are clear from the Federal Procurement and Non-Procurement Program List. All bids will remain valid for 90 days after the bid opening. Except as permitted by law and subject to all applicable remedies, including forfeiture of bidder's security, bidders may not withdraw their bid during the 90 day period after the bid opening.

By order of the City Council of the City of Colfax, Placer County, California.

**TABLE OF CONTENTS**

Instructions to Bidders..... BB-1  
Bidder’s Check List ..... BB-17  
Proposal and Schedule of Bid Prices ..... BB-18  
Bid Bond..... BB-21  
Contractor License Information..... BB-23  
List of Subcontractors..... BB-24  
Workers Compensation Insurance Certification..... BB-27  
Non-Collusion Declaration..... BB-28  
California Debarment Certification ..... BB-29  
Federal Debarment and Suspension Certification ..... BB-30  
Public Contract Code Section 10285.1 Statement..... BB-31  
Public Contract Code Section 10162 Questionnaire ..... BB-32  
Public Contract Code Section 10232 Statement..... BB-33  
Bidder’s Signature Page ..... BB-34  
Contract Check List ..... BB-36  
Agreement..... BB-37  
Performance Bond ..... BB-42  
Payment Bond..... BB-44  
Contract Change Order..... BB-46  
Maintenance Bond..... BB-48  
Escrow Agreement..... BB-50  
City of Colfax Business License Application..... BB-53  
Bidder’s Section 3 Proposed New Hires ..... BB-61  
Bidder’s Proposed Section 3 Contracts/Subcontracts..... BB-62

**ATTACHMENT A – Ineligibility and Voluntary Exclusion Lower Tier Covered Transactions**

**GENERAL PROVISIONS**

<u>SECTION</u>	<u>TITLE</u>	
1.	Definitions .....	1
2.	Scope of Work .....	5
3.	Control of Work and Material and Changes in Work.....	7
4.	Trenching and Utilities and Project Facilities .....	18
5.	Prosecution and Progress of the Work.....	22
6.	Contractor Responsibilities.....	27
7.	Measurement and Payment.....	48
8.	Project Acceptance and Closeout .....	52
9.	Remedies and Disputes.....	54
10	Special Provisions (Technical Specifications).....	66

**APPENDIX A - Labor Compliance and Federal Contract Regulations and Provisions**

**APPENDIX B – Placer County Department of Public Works Standard Details**

**PROJECT PLANS**

Four (4) 11” x 17” Sheets

**INSTRUCTIONS TO BIDDERS**

**1. DEFINITIONS**

- 1.1 Bid forms. The bid forms are the documents listed in the Bidder's Check List in the bid package Table of Contents as comprising the documents that must be submitted for each bid for it to be deemed complete.
- 1.2 Bid package. A complete bid package consists of the following documents: Notice to Bidders, Instructions to Bidders, Bidder's Check List, Proposal and Schedule of Bid Prices, Bid Bond, Contractor License Information, List of Proposed Subcontractors, Workers Compensation Insurance Certification, Non-collusion Declaration, California Debarment Certification, Debarment and Suspension Certification, Public Contract Code Section 10285.1, Public Contract Code Section 10162 Questionnaire, Public Contract Code Section 10232 Statement, Bidder's Questionnaire, if any, Bidder's Signature Page, Contract Check List, Contract, Performance Bond, Payment Bond, Contract Change Order, Maintenance Bond, Escrow for Security Deposit Agreement, Bidder's Section 3 Proposed New Hires, Bidder's Proposed Section 3 Contracts/Subcontracts.
- 1.3 Contract documents. The contract documents are all of the documents incorporated into the final Project contract as listed in the contract.
- 1.4 Project. The Project is the Culver Street Pavement Rehabilitation Project as described in the bid package.
- 1.5 Project Plans. The Project Plans are the primarily graphic detailed requirements concerning the Project contained in the bid package.
- 1.6 Technical Specifications. The Technical Specifications provide detailed requirements concerning the Project and are contained in Special Provisions in the bid package.

**2. BIDDER'S REPRESENTATIONS**

Each bidder by submitting a bid represents that:

- 2.1 The bidder has read and understands the bid package and the bid is in accordance with all of the requirements of the bid package and applicable law.
- 2.2 Neither the bidder nor any subcontractor included on the list of proposed subcontractors submitted with the bid are ineligible to perform work on public works projects pursuant to California Labor Code Sections 1777.1 or 1777.7.
- 2.3 The bidder understands that quantities of unit price items may vary from the estimates provided in the technical specifications.
- 2.4 Representatives of the bidder have visited the Project site and have familiarized themselves with the conditions under which the Project work is to be performed so as to ensure that the Project work may be performed for the amount bid.

- 2.5 The bidder has informed the City in writing no later than five (5) working days prior to the time specified for bid opening of any apparent conflicts, errors, or ambiguities contained in the bid package or between the contents of the bid package and the Project site.

**3. EXAMINATION OF PLANS, SPECIFICATIONS, CONTRACT, AND WORK SITE**

- 3.1 The bidder shall examine carefully the work site, the Project Plans and Technical Specifications, and the entire Bid Package. The submission of a bid shall be conclusive evidence that the bidder has investigated and is satisfied as to the general and local conditions to be encountered, as to the character, quality and scope of work to be performed, the quantities of materials to be furnished and as to the requirements of the Contract Documents.
- 3.2 The submission of a bid shall also be conclusive evidence that the bidder is satisfied as to the character, quality and quantity of surface and subsurface materials or obstacles to be encountered insofar as this information was reasonably ascertainable from an inspection of the site and the records of exploratory work done by the City as shown in the bid documents, as well as from the Project Plans and Technical Specifications.
- 3.3 Where the City has made investigations of work site conditions including subsurface conditions in areas where Work is to be performed, or in other areas, that may constitute possible local material sources, bidders may, upon request, inspect the records of the City as to those investigations.
- 3.4 Where there has been prior construction by the City or other public agencies within the project limits, records of the prior construction that are currently in the possession of the City and that have been used by, or are known to, the designers and administrators of the project will be made available for inspection by bidders, upon request, subject to this Section 3. Such records may include, but are not limited to, as-built drawings, design calculations, foundation and site studies, project reports and other data assembled in connection with the investigation, design, construction and maintenance of the prior projects.
- 3.5 Inspection of the records of investigations and project records in the possession of the City may be made at the Office of the City Clerk.
- 3.6 When a log of test borings or other record of geotechnical data obtained by the City's investigation of surface and subsurface conditions is included with the Project Plans, it is furnished for the bidders' information and its use shall be subject to this Section 3.
- 3.7 In some instances, information considered by the City to be of possible interest to bidders has been compiled as "Materials Information." The use of the "Materials Information" shall be subject to the conditions and limitations set forth in this Section 3.
- 3.8 When cross sections are not included with the Project Plans, but are available, bidders may inspect the cross sections and obtain copies for their use, at their expense.
- 3.9 When cross sections are included with the Project Plans, it is expressly understood and agreed that the cross sections do not constitute part of the Agreement, do not necessarily represent actual site conditions or show location, character, dimensions and details of Work to be



performed, and are included in the Project Plans only for the convenience of bidders and their use is subject to the conditions and limitations set forth in this Section 3.

- 3.10 When contour maps were used in the design of the project, bidders may inspect those maps, and if available, they may obtain copies for their use.
- 3.11 The availability or use of information described in this Section 3 is not to be construed in any way as a waiver of any of the provisions in this Section 3 and bidders are cautioned to make independent investigations and examinations as they deem necessary to be satisfied as to conditions to be encountered in the performance of the Work and, with respect to possible local material sources, the quality and quantity of material available from the property and the type and extent of processing that may be required in order to produce material conforming to the requirements of the Technical Specifications.
- 3.12 The City assumes no responsibility for conclusions or interpretations made by a bidder based on the information or data made available by the City. The City does not assume responsibility for representation made by its officers or agents before the execution of the Agreement concerning surface or subsurface conditions, unless that representation is expressly stated in the Contract Documents.
- 3.13 No conclusions or interpretations made by a bidder from the information and data made available by the City will relieve a bidder from properly fulfilling the terms of the Agreement.

**4. PRE-BID COMMUNICATION AND INTERPRETATION OF THE BID PACKAGE**

- 4.1 Any bidder that discovers any apparent conflicts, errors, or ambiguities contained in the bid package or between the contents of the bid package and the Project site, or that has questions or requires clarification concerning the bid package or its intent must inform the City in writing as soon as reasonably possible, but no later than five (5) working days before the date specified for bid opening. Such notice to the City must be sent to the address specified in the Notice to Bidders for questions concerning the bid package. Questions received less than five (5) working days before the time specified for opening bids may not be answered.
- 4.2 Any interpretation, correction or change of the bid package prior to bid opening will be made by addendum signed by an authorized representative of the City and transmitted to all bid package recipients. No other interpretation or information concerning the bid package issued prior to the date specified for opening bids will be binding. All addenda signed by an authorized representative of the City and issued prior to the time and date specified for opening bids will form a part of the contract documents and must be acknowledged on the bid forms. Any changes, exceptions or conditions concerning the Project and/or the bid package submitted by any bidder as part of a bid may render that bid non-responsive.

**5. PRE-BID ACCESS TO THE PROJECT SITE**

- 5.1 Prior to submitting a bid, it will be the sole responsibility of each bidder to conduct any additional examination, investigation, exploration, testing, study or other inquiry and to obtain any additional information pertaining to the physical conditions (including surface, subsurface, and underground utilities) at or near the Project site that may affect the cost, progress, or

performance of the Project, and that the bidder deems are necessary to prepare its bid for performance of the Project in accordance with the bid package and contract documents. Bidders seeking any such additional examination or other inquiries or information concerning the Project will do so at the bidder's sole expense.

- 5.2 Bidders seeking to conduct any additional examination or other inquiry at the Project site must request site access from the City at least two (2) working days in advance. The location of any excavation, boring or other invasive testing will be subject to approval on behalf of the City and any other agencies with jurisdiction over such testing. Bidders may not conduct tests at the Project site prior to obtaining City approval. The City may require bidders to execute an access agreement prior to approving testing at the Project site. Once approved testing is complete, Bidders must fill all trenches or holes, restore all pavement to match existing structural section, and otherwise clean up and restore the test site to its pre-test condition.

**6. BIDDING PROCEDURE**

- 6.1 Bids must be delivered to the City of Colfax, 33 South Main Street, P.O. Box 702, Colfax, California, 95713, no later than the time and date specified in the Notice to Bidders. Bids will be opened and read publicly at that time. Bids that are submitted late according to the official time kept by the City Clerk will be returned unopened. Telephones for use by bidders are not available at the City offices.
- 6.2 In accordance with California Public Contract Code Section 20170, Bids must be presented under sealed cover. Bids must be submitted using the bid forms furnished with the bid package. Bids must include all documents listed in the Bidder's Check List completed in accordance with the bid package. Bids must bear the bidder's legal name and be signed by a representative authorized to bind the bidder. Bids must be typed or written in ink. Corrections may be made if initialed by the individual signing the bid. No oral or telegraphic modifications of bids, including facsimile modifications, will be considered. Bids that are incomplete or that are not presented on the bid forms furnished with the bid package may be deemed non-responsive.
- 6.3 Each bid must give the full business address of the bidder. Bids of partnerships must furnish the full name of all partners and must be signed in the partnership name by one of the members of the partnership, or by an authorized representative, followed by the printed name and title of the person signing. Bids of corporations must be signed with the legal name of the corporation, followed by the name of the state of incorporation and by the signature and designation of the president, secretary or other person authorized to bind the corporation. The name of each person signing shall also be typed or printed below the signature. Upon request of the City, bidders will furnish satisfactory evidence of the authority of the person signing the bid. Bids of joint ventures must include a certified copy of the legal agreement constituting the joint venture.
- 6.4 No person, firm, corporation, partnership or legal joint venture may submit more than one bid for the Project. However, a person, firm, corporation, partnership or legal joint venture that has submitted a subcontract proposal to a bidder, or that has quoted prices on materials to a bidder may submit a subcontract proposal, quote prices to other bidders and submit its own bid.

- 6.5 In accordance with California Public Contract Code Section 20170, all bids must include one of the forms of bidder's security specified in the Notice to Bidders in an amount of at least ten (10) per cent of the total of the bid prices for the base bid and those additive or deductive items specifically identified in the Notice to Bidders for the purpose of determining the lowest price bid. Bidders that elect to provide bidder's security in the form of a bid bond must execute a bid bond using the form provided in the bid forms. The bidder's security is tendered as a guarantee that the successful bidder, if awarded the Project contract, will execute and submit to the City all required bonds, certificates of insurance, completed contract forms and other documents listed in the Contract Check List and enter into a contract with the City within ten (10) working days of date of the notice of award. The bidder's security of any successful bidder that fails to do so will be forfeited to the City. All bidders' security not forfeited to the City will be returned once a successful bidder provides all required documents and enters a contract with the City in accordance with all applicable bid package requirements. Forfeiture of the bidder's security to the City will not waive or otherwise limit any other remedy available to the City under applicable law.
- 6.6 In accordance with California Business and Professions Code Section 7028.15, Public Contract Code Section 20103.5, and as specified in the Notice to Bidders, all Project work must be performed by properly licensed contractors and subcontractors with active licenses in good standing as of the date and time specified for bid opening, or, if the Project involves federal funds, no later than the time the Project contract is awarded. Bidders must verify their Contractor's License number and license expiration date on the proposal cover page under penalty of perjury. Bids that do not satisfy applicable licensing requirements will be considered non-responsive and rejected and may subject the bidder to criminal and/or civil penalties.
- 6.7 In accordance with California Civil Code Section 1771.1, the City shall accept bids only from bidders which (along with all listed subcontractors) are currently registered and qualified to perform public work pursuant to Civil Code Section 1725.5. The City may, however, accept a non-complying bid provided that bidder (and all listed subcontractors) are registered and qualified at the time of award.
- 6.8 If the bid forms include a bidder's questionnaire, all bids must include a completed bidder's questionnaire on the forms provided. By submitting a bid, bidders authorize City representatives to verify any and all information provided on the bidder's questionnaire and agree to indemnify, defend and hold harmless the City and its officials, officers, employees, agents and volunteers to the full extent permitted by law from and against any claims, liability or causes of action, including, without limitation, legal fees and costs, arising out of verification of the information provided on the bidder's questionnaire, and/or arising out of use of information provided in the bidder's questionnaire to determine, in accordance with applicable law, the qualification of the bidder for performing the Project.
- 6.9 Bids may be withdrawn prior to the time set for bid opening by a written request signed by an authorized representative of the bidder filed with the City Clerk. The bid security submitted with bids so withdrawn will be returned to the bidder. Bidders that have withdrawn their bid in accordance with this provision may submit a new bid prior to the time set for bid opening in accordance with all applicable bid package requirements. Bids may not be withdrawn during the ninety day period after the time set for bid opening except as permitted by law pursuant to

California Public Contract Code Section 5100 and following sections. Any other bid withdrawal will result in forfeiture of the bidder's bid security to the City.

**7. BID PROTESTS**

- 7.1 Any protest of the proposed Project award must be submitted in writing to the City no later than 5:00 PM on the third business day following the date of the bid opening.
- 7.2 The protest must contain a complete statement of the basis for the protest.
- 7.3 The protest must state the facts and refer to the specific portion of the document or the specific statute that forms the basis for the protest. The protest must include the name, address, and telephone number of the person representing the protesting party.
- 7.4 The party filing the protest must concurrently transmit a copy of the protest to the proposed awardee.
- 7.5 The party filing the protest must have actually submitted a bid for the Project. A subcontractor of a party filing a bid for the Project may not submit a bid protest. A party may not rely on the bid protest submitted by another bidder, but must timely pursue its own protest.
- 7.6 The procedure and time limits set forth in these Instructions to Bidders are mandatory and are the bidders' sole and exclusive remedy in the event of a bid protest. Any bidder's failure to fully comply with these procedures shall constitute a waiver of any right to further pursue a bid protest, including filing of a challenge of the award pursuant to the California Public Contract Code, filing of a claim pursuant to the California Government Code, or filing of any other legal proceedings.
- 7.7 The City shall review all timely protests prior to award of the Project. The City shall not be required to hold an administrative hearing to consider any protests, but may do so at its option. At the time of the City Council's consideration of the Project award, the City Council shall also consider the merits of any timely protests. The City Council may either reject the protest and award to the lowest responsible bidder or accept the protest and award the bid to the next lowest responsible bidder. Nothing in this section shall be construed as a waiver of the City Council's right to reject all bids.

**8. AWARD**

- 8.1 In accordance with applicable law, the City reserves the right to reject any or all bids and to waive any informality in any bid. The City reserves the right to accept any portion of any bid, unless the bid package expressly provides that the award will be made as a whole. If the City elects to award a contract for performance of the Project, the contract will be awarded in accordance with California Public Contract Code Section 20162 and other applicable law to the responsible bidder submitting a responsive bid with the lowest total bid price for the base bid without consideration of the bid prices for additive or deductive alternate items listed in the Notice to Bidders, and who has been checked and cleared (along with all named subcontractors) from the Federal Procurement and Non-Procurement Program List. In accordance with the contract documents and other applicable law, the City may add or deduct items of work from the Project after the lowest responsible bidder is determined.

- 8.2 The successful bidder must submit to the City complete, executed copies of all documents specified in the Contract Checklist within ten (10) working days of date of written notice of award of the Project. Bidder's security of any successful bidder that fails to do so will be forfeited to the City.
- 8.3 The successful bidder and any subcontractors and others engaged in performance of the Project must have valid local business license(s), as applicable, and must submit a Form W-9 (Taxpayer Identification Number and Certification) before commencing work on the Project. Both the Business License form and the W-9 form can be found in this document for your use.
- 8.4 The successful bidder and any subcontractors and others engaged in performance of the Project must have valid local business license(s), as applicable, before commencing work on the Project.
- 8.5 Upon verifying that the successful bidder has provided complete, executed copies of all documents specified in the Contract Checklist an authorized City representative will execute the Project contract, and the City will issue to the successful bidder a notice to proceed specifying the Project commencement date. The number of days within which the Project must be complete begins to run on the Project commencement date.

**9. PRICING**

- 9.1 If an inconsistency exists between the amount listed for a unit price in a bid and the total listed for that bid item (e.g., if the total listed for a bid item does not equal the unit price listed in the bid multiplied by the quantity listed), subject to applicable law, the unit price will be deemed to accurately reflect the bidder's intent concerning the bid item and the intended total for the bid item will be deemed to be the unit price as listed in the bid multiplied by the quantity listed.
- 9.2 If the Project bid price is a lump sum total made up of smaller individual bid item prices and an inconsistency exists between the lump sum total bid price and any individual bid item price, subject to applicable law, the individual bid item prices as listed in the bid will be deemed to accurately reflect the bidder's intended bid for the Project and the intended lump sum total bid for the Project will be deemed to be the sum of the individual bid item prices as listed in the bid, even if that sum is different from the amount actually listed as the lump sum total bid for the Project.
- 9.3 Any federal, state, or local tax payable on articles to be furnished for the Project shall be included in the lump sum total bid price and paid by the Contractor under the contract. The City is exempt from federal excise tax and will provide a certificate of exemption to the successful bidder upon request.

**10. QUANTITIES**

- 10.1 Quantities, including but not limited to, material or labor quantities, that are provided in the bid package concerning the Project are estimates only and are provided solely as a general indication of the Project scope. The City does not warrant that such quantity estimates provided in the bid package represent the actual quantities required to perform the Project in accordance with the contract documents. Such quantity estimates do not bind the City, and

bidders should not rely on them in preparing their bids. Each bidder is solely responsible for determining the quantities on which to base their bids in light of information contained in the bid package, bidder investigation and analysis of the Project and the Project site, and any other analysis or expertise of the bidder concerning the Project.

- 10.2 The City may amend, decrease or increase the Project work in accordance with the bidding package and the contract documents. If the City amends, decreases or increases the Project work prior to award of the Project each bidder will be solely responsible for determining the revised quantities, if any, on which to base their bid in light of information contained in the bid package and any amendments or addenda to the bid package, bidder investigation and analysis of the Project as amended, decreased or increased, the Project site, and any other analysis or expertise of the bidder concerning the Project.

**11. SUBSTITUTION OF “OR EQUAL” ITEMS**

- 11.1 In accordance with California Public Contract Code Section 3400, where the Technical Specifications or Project Plans list products by manufacturer's name, brand or model number such information indicates the quality and utility of the items desired and does not restrict bidders to that manufacturer's name, brand or model number, unless the Technical Specifications or Project plans specify that the listed product is necessary to match others in use on a particular public improvement either completed or in the course of completion. Except where the Technical Specifications indicate that a particular brand product is necessary to match others in use, when a manufacturer’s name, brand or model number is listed, it shall be construed to be followed by the words "or equal" whether or not those words in fact follow the manufacturer’s name, brand name or model number listed in the Technical Specifications or Project Plans. Unless the Technical Specifications or Project Plans indicate that a particular brand product is necessary to match others in use, bidders may propose equals of products listed by manufacturer name, brand name or model number.
- 11.2 Complete information for products proposed as equals must be submitted to the City for review by at least ten (10) working days before the time specified for opening bids. To be considered, proposals concerning products proposed as equals must include sufficient information to permit the City to determine whether the products proposed as equals will satisfy the same performance requirements as products listed by manufacturer’s name, brand or model number. Such performance requirements may include, but are not limited to, size, strength, function, appearance, ease of maintenance and repair, and useful life requirements. Proposals concerning products proposed as equals that are submitted later than ten (10) working days before the time specified for opening bids will not be considered. Failure to bid products specified by manufacturer name, brand name or model number where the Technical Specifications or Project Plans specify that a particular product is necessary to match others in use, or where no proposal concerning products proposed as equals has been submitted in accordance with this provision may render a bid non-responsive.

**12. SUBCONTRACTING**

- 12.1 Bids must be in accordance with the requirements of the Subletting and Subcontracting Fair Practices, Act, California Public Contract Code Section 4100 and following. Bids must include a completed list of proposed subcontractors on the form included in the bid package. In accordance with California Public Contract Code Section 4104, completed lists of

proposed subcontractors must include the name, business location, the portion (type or trade), and dollar amount of the Project work to be subcontracted for each subcontractor that will perform a portion of the Project work (including special fabrication and installation of a portion of the work) valued in excess of one half of one percent of the total Project bid price. If the Project work includes construction of streets or highways, the completed list of proposed subcontractors must include the subcontractor name, business location, type of work and dollar amount to be subcontracted for each subcontractor that will perform a portion of the Project work (including special fabrication and installation of a portion of the work) valued in excess of one half of one percent of the total Project bid price, or ten thousand dollars (\$10,000), whichever is greater.

- 12.2 In accordance with California Public Contract Code Section 4106, for any portion of the Project work with a value of more than one half of one percent of the total Project bid price for which no subcontractor is listed, or for which more than one subcontractor is listed, bidders certify by submitting their bids that they are qualified to perform that portion of the Project work and that they will perform that portion of the Project work with their own forces. Bidders may not substitute another subcontractor for a subcontractor listed in their bid except as permitted by the City in accordance with Section 4107 and following sections of the California Public Contract Code.

**13. ASSIGNMENT**

Bidders may not assign, sublet, sell, transfer, or otherwise dispose of their bid or any right, title or interest in their bid, or their obligations under their bid, without the written consent of an authorized representative of the City. Any purported assignment, subletting, sale, transfer or other disposition of a bid or any interest in a bid, or of any obligations under a bid without such written consent will be void and of no effect.

**14. BONDS**

- 14.1 The successful bidder must submit to the City a performance bond within ten (10) working days of date of written notice of award. If the Project involves expenditures in excess of twenty five thousand dollars (\$25,000), the successful bidder must submit to the City a payment or labor and materials bond within ten (10) working days of date of written notice of award. Prior to issuance of the final Project payment, the successful bidder must submit a maintenance bond. All bonds must be executed by corporate sureties who are admitted surety insurers in the State of California in accordance with applicable law and acceptable to the City. Individual sureties will not be accepted. All Project bonds must be executed using the forms provided in the bid package.
- 14.2 In accordance with California Civil Code Section 9554, the payment or labor and materials bond must be in the amount of one hundred percent of the total amount payable by the terms of the Project contract and guarantee payment to persons listed in California Civil Code Section 9100 for work performed and for charges for materials, supplies, and equipment provided under the Project contract (including amounts due under or subject to the Unemployment Insurance Code).
- 14.3 The performance bond must be in the amount of one hundred percent of the amount payable by the terms of the Project contract to guarantee the faithful performance of the Project work.

- 14.4 The maintenance bond must be in the amount of ten percent of the final Project contract amount and guaranty the Project work against defects in materials, equipment, workmanship, or needed repair for one year from the City's acceptance of the Project work.

**15. LABOR LAWS**

- 15.1 Bidders must comply with applicable provisions of the California Labor Code.
- 15.2 In accordance with California Labor Code Section 1861, bids must include a workers compensation insurance certification on the form included in the bid package.
- 15.3 In accordance with California Labor Code Section 1777.1, contractors and subcontractors that are found guilty of willfully violating Chapter 1 of Part 7 of Division 2 of the Labor Code (except for Section 1777.5), or that are found guilty of such violations with intent to defraud, and entities in which such contractors or subcontractors have any interest, may be ineligible to bid on, be awarded, or perform Project work as a subcontractor.
- 15.4 Pursuant to Section 1773 of the Labor Code, the Owner has obtained from the Director of the Department of Industrial Relations (DIR), the general prevailing wage rates for each craft, classification, or type of workman required in the county, or counties, in which the work is to be done. These wages are set forth in the General Prevailing Wage Rates for this project, available at the City of Colfax and available from the California Department of Industrial Relations' Internet web site at <http://www.dir.ca.gov/DLSR/PWD>. The Federal minimum wage rates for this project as predetermined by the United States Secretary of Labor are contained in Appendix A of the Contract Documents. Addenda to modify the Federal minimum wage rates, if necessary, will be issued to holders of Bid book. Future effective general prevailing wage rates, which have been predetermined and are on file with the California Department of Industrial Relations are referenced but not printed in the general prevailing wage rates.
- 15.5 Attention is directed to the Federal minimum wage rate requirements in the Bid book. If there is a difference between the minimum wage rates predetermined by the Secretary of Labor and the general prevailing wage rates determined by the Director of the California Department of Industrial Relations for similar classifications of labor, the Contractor and subcontractors shall pay not less than the higher wage rate. The Department will not accept lower State wage rates not specifically included in the Federal minimum wage determinations. This includes "helper" (or other classifications based on hours of experience) or any other classification not appearing in the Federal wage determinations. Where Federal wage determinations do not contain the State wage rate determination otherwise available for use by the Contractor and subcontractors, the Contractor and subcontractors shall pay not less than the Federal minimum wage rate, which most closely approximates the duties of the employees in question.
- 15.6 A Contractor or Subcontractor shall not be qualified to bid on, be listed in a bid proposal, subject to the requirements of Section 4104 of the Public Contract Code, or engage in the performance of any contract for public work, as defined in this chapter, unless currently registered and qualified to perform public work pursuant to Section 1725.5. It is not a violation of this section for an unregistered contractor to submit a bid that is authorized by



Section 7029.1 of the business and Professions Code or by Section 10164 or 20103.5 of the Public Contract Code, provided the Contractor is registered to perform public work pursuant to Section 1725.5 at the time the Contract is awarded. Labor Code Section 1771.1(a) requires Contractors and their Subcontractors to possess and maintain such registration with DIR in order to be awarded and to perform on public works projects (regardless of funding source).

- 15.7 Pursuant to Section 1771.4, each CONTRACTOR and SUBCONTRACTOR shall furnish certified payroll records to the Labor Commissioner at least monthly and in a format prescribed by the Labor Commissioner of the DIR. Until such time that the DIR gives awarding agencies direct access to all certified payrolls submitted by CONTRACTORS and SUBCONTRACTORS, CONTRACTOR and his SUBCONTRACTORS are also required to submit copies of payroll records to OWNER on a monthly basis. Information on the above can be found at: <http://www.dir.ca.gov/Public-Works/PublicWorks.html>.

**BIDDER'S CHECK LIST**

Did You:

- \_\_\_\_\_ Submit equal product proposals, if any, in accordance with the instructions to bidders included in the bid package at least 10 working days before the time specified for opening bids, and have said substitutions approved in writing? Include a copy of the approved submittal.
  
- \_\_\_\_\_ Verify that the following documents in the bid book have been properly completed:
  - \_\_\_\_\_ Bidder's check list.
  - \_\_\_\_\_ Proposal and Schedule of Bid Prices that state the bid as intended.
  - \_\_\_\_\_ Executed bid bond.
  - \_\_\_\_\_ Contractor license information.
  - \_\_\_\_\_ Contractor DIR registration information
  - \_\_\_\_\_ Evidence of active D-U-N-S number?
  - \_\_\_\_\_ List of subcontractors, including DIR registration information.
  - \_\_\_\_\_ Non Collusion Affidavit.
  - \_\_\_\_\_ Workers compensation insurance certification.
  - \_\_\_\_\_ Signed and notarized Non-Collusion Declaration.
  - \_\_\_\_\_ California Debarment Certification.
  - \_\_\_\_\_ Federal Debarment Certification.
  - \_\_\_\_\_ Public Contract Code Section 10285.1 Statement.
  - \_\_\_\_\_ Public Contract Code Section 10162 Questionnaire.
  - \_\_\_\_\_ Public Contract Code Section 10232 Statement.
  - \_\_\_\_\_ Bidder's questionnaire, if any.
  - \_\_\_\_\_ Executed bidder's signature page.
  - \_\_\_\_\_ Bidder's Proposed Section 3 Contracts/Subcontracts?
  - \_\_\_\_\_ Bidder's Section 3 Proposed New Hires?
  - \_\_\_\_\_ Use federal wage rates which are current as of 10 days prior to bid?
  - \_\_\_\_\_ Use If any, copy of each addendum issued signed and dated by the bidder.
  
- \_\_\_\_\_ Arrange to have the sealed bid delivered to the Office of the City Clerk in the City of Colfax offices at 33 South Main Street, P.O. Box 702 Colfax, California 95713 on or before the time specified for bid opening in the notice inviting bids.

Only the above mentioned documents need be filled out to submit a bid.

DO NOT DETACH

**PROPOSAL****For: Construction of the Culver Street Pavement Rehabilitation Project**

For the City of Colfax, Placer County, California.

TO THE HONORABLE CITY COUNCIL  
OF THE CITY OF COLFAX

The undersigned, as bidder, declares that it has carefully examined the work, the annexed proposed form of contract, and agrees that if this Proposal is accepted to contract with the City of Colfax, under the form of contract annexed hereto, to provide all the necessary tools, apparatus, and other means of accomplishing the work as specified in the contract in the manner and time herein prescribed, and in accordance with the requirements of the Public Works Department as therein set forth, and to take in full payment thereof the following prices of the work to be done completely performed to the satisfaction of the City of Colfax, to-wit:

**Contractor's Bid Proposal**  
**Culver Street Pavement Rehabilitation Project**

Item No.	Item Description	Estimated Quantity	Unit of Measure	Unit Cost (in figures)	Total Cost (in figures)
1	Traffic Control	1	LS	\$	\$
2	Adjust Manhole Frame and Cover to Grade	3	EA	\$	\$
3	Adjust Water Valve Frame and Cover to Grade	3	EA	\$	\$
4	Roadway Excavation (F)	338	CY	\$	\$
5	Asphalt Concrete	687	TON	\$	\$
6	Asphalt Concrete Dike, Type E	292	LF	\$	\$
7	Pavement Reinforcing Fabric	1,735	SY	\$	\$
8	Water Line Protective Cap	120	CY	\$	\$
9	Minor Concrete, Valley Gutter	755	SF	\$	\$
10	Drainage Inlet, 24" x 24"	1	EA	\$	\$
11	Drainage Inlet, 18" x 18"	1	EA	\$	\$
12	12" Storm Drain Pipe	30	LF	\$	\$
13	Mobilization	1	LS	\$	\$

**Total Bid:** \$**Dollars****Written Amount**

The City of Colfax has obtained from the Department of Housing and Community Development CDBG Program, the Federal Wage Decision listing the general prevailing wages and fringes in the County in which said work is to be performed for each craft and type of worker or mechanic needed to execute the contract. A copy of the Federal Wage Decision is included in the bid documents. The successful Contractor shall post said prevailing wage rates in a prominent place at the job site. If there is a discrepancy or difference between the state prevailing wage rate and the federal prevailing wage rate, the higher rate will apply.

The undersigned further agrees to deliver and to complete the work within **30 working days**, from the date of issuance, by the City, of instructions to proceed with the work, and within 10 working days of the date of the notice of award, to enter into and execute and provide to the City the necessary contract with the necessary bonds and other required documents, and in case of default in executing the necessary contract within the time fixed by the Instructions to Bidders, the bidder's security accompanying this bid shall become the property of and be forfeited to the City of Colfax.

Prime Contractor \_\_\_\_\_

License # \_\_\_\_\_ Expiration Date \_\_\_\_\_

DIR Registration # \_\_\_\_\_ Expiration Date \_\_\_\_\_

D-U-N-S # \_\_\_\_\_ Expiration Date \_\_\_\_\_

EIN # \_\_\_\_\_ Expiration Date \_\_\_\_\_

Contractor's License number and expiration date are herein stated under penalty of perjury.

By: \_\_\_\_\_ Title: \_\_\_\_\_

Dated this \_\_\_\_\_ day of \_\_\_\_\_, 20\_\_\_\_\_

(Corporate Seal)

Corporate Signature

\_\_\_\_\_

Address: \_\_\_\_\_

Phone No.: \_\_\_\_\_

President's signature \_\_\_\_\_

Secretary's signature \_\_\_\_\_

Corporation organized under the laws of the State of \_\_\_\_\_

Partnership Name: \_\_\_\_\_

Address: \_\_\_\_\_

Names of Co-Partners and Addresses:

---

---

---

Names of Individuals and Addresses:

---

---

NOTE: Sign in proper space above.

**CITY OF COLFAX**  
33 South Main Street  
P.O. Box 702  
Colfax, California 95713

**BID BOND**

*(NOTE: Bidders must use this form, use of any other bond form may render a bid non-responsive)*

KNOW ALL MEN BY THESE PRESENTS:

That we, as PRINCIPAL, and \_\_\_\_\_, a (sole proprietorship/corporation/partnership/joint venture) organized and existing under and by virtue of the laws of the State of \_\_\_\_\_ and an admitted surety insurer authorized to do business in the State of California, as SURETY, are held and firmly bound unto the City of Colfax, as OBLIGEE, in a penal sum equal to ten-percent (10%) the total bid price including the base bid and alternates specified in the proposal of the PRINCIPAL, to the OBLIGEE for the work described below, which penal sum is \_\_\_\_\_ (\$ \_\_\_\_\_) lawful money of the United States of America, for the payment of which sum well and truly to be made, we, and each of us, bind ourselves, our heirs, executors, administrators, successors, and assigns, jointly and severally, firmly by these presents.

THE CONDITION OF THIS OBLIGATION IS SUCH that whereas the PRINCIPAL has submitted the accompanying proposal dated \_\_\_\_\_, \_\_\_\_\_ to the OBLIGEE, for the **Culver Street Pavement Rehabilitation Project** (designated as the "Project") which proposal is hereby made a part hereof;

NOW THEREFORE, if the PRINCIPAL shall not withdraw said proposal within the ninety (90) day period following the opening of bids, and if the PRINCIPAL receives written notice that the Project is awarded to the PRINCIPAL and shall, within ten (10) calendar days of receiving such notice: enter into a written contract with the OBLIGEE in the form prescribed in the bid package issued by the OBLIGEE concerning the Project; and give insurance and bond with good and sufficient sureties guaranteeing the faithful performance and proper fulfillment of such contract and guaranteeing payment for labor and materials used for performance of the contract as required by law; and file with the OBLIGEE all required documents and do all other thing required in accordance with the bid package issued by the OBLIGEE concerning the Project for the contract between the PRINCIPAL and the OBLIGEE to become effective and for work to commence in accordance with the bid package issued by the OBLIGEE concerning the Project , or, in the event of withdrawal of the accompanying proposal within the ninety (90) day period following the opening of bids; or failure by the PRINCIPAL to enter into such contract with the OBLIGEE or to give the OBLIGEE such bonds or to file any other documents or to do any other things required in the bid package issued by the OBLIGEE for the Project, if the PRINCIPAL shall pay the OBLIGEE the difference between the total bid price in the accompanying proposal and the amount for which the OBLIGEE may procure the required performance, if the latter amount be in excess of the former, together with all costs incurred by the OBLIGEE in again attempting to let the Project, and if the said PRINCIPAL shall fully reimburse and save harmless the OBLIGEE from any damage sustained by the OBLIGEE through failure of the PRINCIPAL to enter into the written contract or to file the required performance or labor and material bonds, or to file any other required documents or to do any other things required for the contract

between the PRINCIPAL and the OBLIGEE to become effective and the work to commence in accordance with the bid package issued by the OBLIGEE concerning the Project, then this obligation shall be null and void; otherwise, it shall be and remain in full force and effect.

SURETY, for value received, hereby stipulates and agrees that no change, extension of time, alteration or addition to the terms of the bid or contract documents for the Project, or to the specifications included in the same, or to the work to be performed thereunder, or to the notice to bidders, or to any other documents concerning the Project, shall in anywise affect SURETY's obligation under this bond, and SURETY hereby waives notice of any such change, extension of time, alteration or addition to such bid or contract documents.

In the event suit is brought upon this bond by the OBLIGEE and judgment is recovered, the SURETY shall pay all costs incurred by the OBLIGEE in such suit, including a reasonable attorney's fee to be fixed by the Court.

IN WITNESS WHEREOF, the above-bound parties have executed this instrument under their several seals this \_\_\_\_\_ day of \_\_\_\_\_, \_\_\_\_\_, the name and corporate seals of each corporate party being hereto affixed and these presents duly signed by their undersigned representatives, pursuant to authority of their governing bodies.

(Corporate Seal) PRINCIPAL \_\_\_\_\_  
By \_\_\_\_\_

(Acknowledgement) Title \_\_\_\_\_  
SURETY \_\_\_\_\_  
(Corporate Seal)

By \_\_\_\_\_  
(Attorney-in-fact)

(Acknowledgement) Title \_\_\_\_\_

*(NOTE TO SURETY COMPANY: A certified copy of unrevoked resolution of authority for the attorney-in-fact must be submitted with and attached to the executed bid bond.)*

**CONTRACTOR LICENSE INFORMATION**

The bidder acknowledges that a license is required for performance of the **Culver Street Pavement Rehabilitation Project**.

The bidder holds the following California Contractors License(s):

- 1. License No. \_\_\_\_\_, Class \_\_\_\_\_, Expiration Date \_\_\_\_\_
- 2. License No. \_\_\_\_\_, Class \_\_\_\_\_, Expiration Date \_\_\_\_\_
- 3. License No. \_\_\_\_\_, Class \_\_\_\_\_, Expiration Date \_\_\_\_\_
- 4. License No. \_\_\_\_\_, Class \_\_\_\_\_, Expiration Date \_\_\_\_\_
- 5. License No. \_\_\_\_\_, Class \_\_\_\_\_, Expiration Date \_\_\_\_\_
- 6. License No. \_\_\_\_\_, Class \_\_\_\_\_, Expiration Date \_\_\_\_\_
- 7. License No. \_\_\_\_\_, Class \_\_\_\_\_, Expiration Date \_\_\_\_\_
- 8. License No. \_\_\_\_\_, Class \_\_\_\_\_, Expiration Date \_\_\_\_\_
- 9. License No. \_\_\_\_\_, Class \_\_\_\_\_, Expiration Date \_\_\_\_\_
- 10. License No. \_\_\_\_\_, Class \_\_\_\_\_, Expiration Date \_\_\_\_\_

Bidder's Taxpayer Identification No. \_\_\_\_\_



**LIST OF SUBCONTRACTORS**

In accordance with the requirements of the Subletting and Subcontracting Fair Practices Act, California Public Contract Code Section 4100 and following, listed below are the name, business location, and the portion (type or trade) of the Project work to be subcontracted to each subcontractor that will perform a portion of the Project work (including special fabrication and installation of a portion of the work) valued in excess of one half of one percent of the total bid price. If the Project work includes construction of streets or highways, listed below are the name, business location, and the portion (type or trade) of the Project Work to be subcontracted to each subcontractor that will perform a portion of the Project work (including special fabrication and installation of a portion of the work) valued in excess of one half of one percent of the total Project bid price, or ten thousand dollars, whichever is greater. Also listed below are the proposed subcontract dollar amount and current California Contractor’s License Number(s) for each proposed subcontractor. Bids that fail to include complete proposed subcontractor information in accordance with this form and Public Contract Code Section 4100 and following may be deemed non-responsive.

In accordance with California Public Contract Code Section 4106, for any portion of the Project work with a value of more than one half of one percent of the total bid price for which no subcontractor is listed, or for which more than one subcontractor is listed, the bidder certifies by submission of its bid that the bidder is qualified to perform that portion of the Project work and that the bidder will perform that portion of the Project work with its own forces. The penalties listed in California Public Contract Code Section 4111 will apply to any substitution of another subcontractor for a subcontractor listed below except as permitted by the City in accordance with Section 4107 and following of the California Public Contract Code.

- 1. Subcontractor Name \_\_\_\_\_  
 Business Location \_\_\_\_\_  
 Trade \_\_\_\_\_  
 Subcontract Amount \_\_\_\_\_  
 Current Contractor’s License No.(s) \_\_\_\_\_  
 Current DIR Registration No. \_\_\_\_\_  
 Current EIN No. \_\_\_\_\_
- 2. Subcontractor Name \_\_\_\_\_  
 Business Location \_\_\_\_\_  
 Trade \_\_\_\_\_  
 Subcontract Amount \_\_\_\_\_  
 Current Contractor’s License No.(s) \_\_\_\_\_  
 Current DIR Registration No. \_\_\_\_\_  
 Current EIN No. \_\_\_\_\_
- 3. Subcontractor Name \_\_\_\_\_  
 Business Location \_\_\_\_\_  
 Trade \_\_\_\_\_  
 Subcontract Amount \_\_\_\_\_  
 Current Contractor’s License No.(s) \_\_\_\_\_  
 Current DIR Registration No. \_\_\_\_\_  
 Current EIN No. \_\_\_\_\_
- 4. Subcontractor Name \_\_\_\_\_  
 Business Location \_\_\_\_\_  
 Trade \_\_\_\_\_

- Subcontract Amount \_\_\_\_\_
- Current Contractor's License No.(s) \_\_\_\_\_
- Current DIR Registration No. \_\_\_\_\_
- Current EIN No. \_\_\_\_\_
- 5. Subcontractor Name \_\_\_\_\_
- Business Location \_\_\_\_\_
- Trade \_\_\_\_\_
- Subcontract Amount \_\_\_\_\_
- Current Contractor's License No.(s) \_\_\_\_\_
- Current DIR Registration No. \_\_\_\_\_
- Current EIN No. \_\_\_\_\_
- 6. Subcontractor Name \_\_\_\_\_
- Business Location \_\_\_\_\_
- Trade \_\_\_\_\_
- Subcontract Amount \_\_\_\_\_
- Current Contractor's License No.(s) \_\_\_\_\_
- Current DIR Registration No. \_\_\_\_\_
- Current EIN No. \_\_\_\_\_
- 7. Subcontractor Name \_\_\_\_\_
- Business Location \_\_\_\_\_
- Trade \_\_\_\_\_
- Subcontract Amount \_\_\_\_\_
- Current Contractor's License No.(s) \_\_\_\_\_
- Current DIR Registration No. \_\_\_\_\_
- Current EIN No. \_\_\_\_\_
- 8. Subcontractor Name \_\_\_\_\_
- Business Location \_\_\_\_\_
- Trade \_\_\_\_\_
- Subcontract Amount \_\_\_\_\_
- Current Contractor's License No.(s) \_\_\_\_\_
- Current DIR Registration No. \_\_\_\_\_
- Current EIN No. \_\_\_\_\_
- 9. Subcontractor Name \_\_\_\_\_
- Business Location \_\_\_\_\_
- Trade \_\_\_\_\_
- Subcontract Amount \_\_\_\_\_
- Current Contractor's License No.(s) \_\_\_\_\_
- Current EIN No. \_\_\_\_\_
- 10. Subcontractor Name \_\_\_\_\_
- Business Location \_\_\_\_\_
- Trade \_\_\_\_\_
- Subcontract Amount \_\_\_\_\_
- Current Contractor's License No.(s) \_\_\_\_\_
- Current DIR Registration No. \_\_\_\_\_
- Current EIN No. \_\_\_\_\_
- 11. Subcontractor Name \_\_\_\_\_
- Business Location \_\_\_\_\_
- Trade \_\_\_\_\_
- Subcontract Amount \_\_\_\_\_

Current Contractor's License No.(s) \_\_\_\_\_

Current DIR Registration No. \_\_\_\_\_

Current EIN No. \_\_\_\_\_

12. Subcontractor Name \_\_\_\_\_

Business Location \_\_\_\_\_

Trade \_\_\_\_\_

Subcontract Amount \_\_\_\_\_

Current Contractor's License No.(s) \_\_\_\_\_

Current DIR Registration No. \_\_\_\_\_

Current EIN No. \_\_\_\_\_

**WORKERS COMPENSATION INSURANCE CERTIFICATION**

By submitting its bid the bidder certifies as follows:

I am aware of the provisions of California Labor Code Section 3700, which require every employer to be insured against liability for workmen's compensation or to undertake self-insurance in accordance with the provisions of the Labor Code, and I will comply with such provisions before commencing performance of the work of this Contract.

**NON-COLLUSION DECLARATION  
TO BE EXECUTED BY BIDDER  
AND SUBMITTED WITH BID**

The undersigned declares:

I am the \_\_\_\_\_ of \_\_\_\_\_, the party making the foregoing bid. The bid is not made in the interest of, or on behalf of, any undisclosed person, partnership, company, association, organization, or corporation. The bid is genuine and not collusive or sham. The bidder has not directly or indirectly induced or solicited any other bidder to put in a false or sham bid. The bidder has not directly or indirectly colluded, conspired, connived, or agreed with any bidder or anyone else to put in a sham bid, or to refrain from bidding. The bidder has not in any manner, directly or indirectly, sought by agreement, communication, or conference with anyone to fix the bid price of the bidder or any other bidder, or to fix any overhead, profit, or cost element of the bid price, or of that of any other bidder. All statements contained in the bid are true. The bidder has not, directly or indirectly, submitted his or her bid price or any breakdown thereof, or the contents thereof, or divulged information or data relative thereto, to any corporation, partnership, company, association, organization, bid depository, or to any member or agent thereof, to effectuate a collusive or sham bid, and has not paid, and will not pay, any person or entity for such purpose.

Any person executing this declaration on behalf of a bidder that is a corporation, partnership, joint venture, limited liability company, limited liability partnership, or any other entity, hereby represents that he or she has full power to execute, and does execute, this declaration on behalf of the bidder.

I declare under penalty of perjury under the laws of the State of California that the foregoing is true and correct and that this declaration is executed on \_\_\_\_\_ [date], at \_\_\_\_\_ [city], \_\_\_\_\_ [state]."

\_\_\_\_\_  
Signature

**CALIFORNIA DEBARMENT CERTIFICATION**

By submitting its bid, the bidder certifies in accordance with California Public Contract Code Section 6109 that neither the bidder nor any subcontractor included on the list of proposed subcontractors submitted with the bid is ineligible to perform work on public works projects pursuant to California Labor Code Sections 1777.1 or 1777.7. In accordance with California Public Contract Code Section 6109, Contractors and subcontractors who are ineligible to perform work on public works projects pursuant to California Labor Code Sections 1777.1 or 1777.7 may neither bid on, be awarded or perform as a subcontractor on public works projects.

**TITLE 49, CODE OF FEDERAL REGULATIONS - PART 29  
DEBARMENT AND SUSPENSION CERTIFICATION**

The bidder, under penalty of perjury, certifies that, except as noted below, he/she or any person associated therewith in the capacity of partner, director, officer, manager:

1. Is not currently under suspension, debarment, voluntary exclusion, or determination of ineligibility by any federal agency; and
2. Has not been suspended, debarred, voluntarily excluded or determined ineligible by any Federal Agency within the past 3 years; and
3. Does not have a proposed debarment pending; and,
4. Has not been indicted, convicted, or had a civil judgment rendered against it by a court of competent jurisdiction in any matter involving fraud or official misconduct within the past 3 years.

If there are any exceptions to this certification, insert the exceptions in the following space:

Exceptions will not necessarily result in denial of award, but will be considered in determining bidder responsibility. For any exception noted above, indicate below to whom it applies, initiating agency, and dates of action.

**PUBLIC CONTRACT CODE SECTION 10285.1 STATEMENT**

In accordance with Public Contract Code Section 10285.1 (Chapter 376, Stats, 1986), The bidder hereby declares under penalty of perjury under the laws of the State of California that the bidder has , has not \_\_\_\_\_ been convicted within the preceding three years of any offenses referred to in that section, including any charge of fraud, bribery, collusion, conspiracy, or any other act in violation of any state or federal antitrust law in connection with the bidding upon, award of, or performance of, any public works contract, as defined in Public Contract Code Section 1100, including the Regents of the University of California or the Trustees of the California State University. The term "bidder" is understood to include any partner, member, officer, director, responsible managing officer, or responsible managing employee thereof, as referred to in Section 10285.1.

Note: The bidder must place a check mark after "has" or "has not" in one of the blank spaces provided.

The above Statement is part of the Proposal. Signing the Contractor's Proposal on the signature portion thereof shall also constitute signature of this Statement.

Bidders are cautioned that making false certification may subject the certifier to criminal prosecution.



**PUBLIC CONTRACT CODE SECTION 10162 QUESTIONNAIRE**

In accordance with Public Contract Code Section 10162, The Bidder shall complete, under penalty of perjury, the following questionnaire:

Has the bidder, any officer of the bidder, or any employee of the bidder who has a proprietary interest in the bidder, ever been disqualified, removed, or otherwise prevented from bidding on, or completing a federal, state, or local government project because of a violation of law or a safety regulation?

Yes \_\_\_\_\_ No \_\_\_\_\_

If the answer is "Yes", explain the circumstances in the following space.

**PUBLIC CONTRACT SECTION 10232 STATEMENT**

In accordance with Public Contract Code Section 10232, the Contractor hereby states under penalty of perjury that no more than one final unappealable finding of contempt of court by a federal court has been issued against the Contractor within the immediately preceding two year period because of the Contractor's failure to comply with an order of a federal court which orders the Contractor to comply with an order of the National Labor Relations Board.

**BIDDER'S SIGNATURE PAGE**

By signing this proposal the bidder certifies, under penalty of perjury under the laws of the State of California, that the information submitted with this proposal for the **Culver Street Pavement Rehabilitation Project** ("Project"), which information includes, but is not limited to, the Bidder's Check List, Proposal and Schedule of Bid Prices, Bid Bond, Contractor License Information, List of Subcontractors, Workers Compensation Insurance Certification, Non-Collusion Declaration, Debarment Certification, Debarment and Suspension Certification, Public Contract Code Section 10285.1 Statement, Public Contract Code Section 10162 Questionnaire, Public Contract Code Section 10232 Statement and Bidder's Questionnaire, if any, is accurate, true and correct, and is submitted in accordance with the requirements of the bid package issued by the City of Colfax concerning Project and applicable law. By signing this proposal, the bidder representative specified below certifies that he or she is legally authorized to bind the bidder and will perform the work in conformance with all required regulations including but not limited to those outlined in Attachment A.

The bidder agrees to deliver and to complete the Project within **30 working days** from the date of issuance, by the City, of instructions to proceed with the Project, and within 10 working days of the date of notice of award, to enter into and execute and provide to the City the Project contract, bonds and all other documents specified in the Contract Check List included in the bid package, and in case of default in executing the Project contract within the time fixed by the Instructions to Bidders, the bidder's security accompanying this bid shall become the property of and be forfeited to the City of Colfax.

Prime Contractor \_\_\_\_\_

By: \_\_\_\_\_ Title: \_\_\_\_\_

Dated this \_\_\_\_\_ day of \_\_\_\_\_, 20\_\_\_\_\_

(Corporate Seal)

Corporate signature

\_\_\_\_\_

Address: \_\_\_\_\_

Phone No.: \_\_\_\_\_

President's signature \_\_\_\_\_

Secretary's signature \_\_\_\_\_

Corporation organized under the laws of the State of \_\_\_\_\_

Partnership Name: \_\_\_\_\_

Address: \_\_\_\_\_

Names of Co-Partners and Addresses:

\_\_\_\_\_  
\_\_\_\_\_  
\_\_\_\_\_

Names of Individuals and Addresses:

---

---

---

NOTE: Sign in proper space above.

Date: \_\_\_\_\_

\_\_\_\_\_  
(Typed or printed name)

\_\_\_\_\_  
(Signature)

\_\_\_\_\_  
(Bidder)

Bidder business address (street, city, state and zip code)

---

---

---

Bidder Business phone: ( ) \_\_\_\_\_

Bidder Business fax: ( ) \_\_\_\_\_

**CONTRACT CHECK LIST**

Complete, accurate, executed copies of the following documents must be submitted to the City of Colfax in accordance with the bid package issued by the City within ten (10) working days of date of written notice of award of the project. The bidder's security of any successful bidder that fails to do so will be forfeited to the City.

\_\_\_\_\_ Contract Check List

\_\_\_\_\_ Agreement

\_\_\_\_\_ Performance Bond

\_\_\_\_\_ Payment Bond

\_\_\_\_\_ Certificates of Insurance and Endorsements

\_\_\_\_\_ Escrow for Deposit Agreement, if applicable

\_\_\_\_\_ General Conditions

AGREEMENT

The City of Colfax, a California Municipal Corporation (“City”) enters into this Agreement, dated \_\_\_\_\_, with \_\_\_\_\_ (“Contractor”).

RECITALS

- A. NOTICE INVITING BIDS. The City gave notice inviting bids to be submitted by 2:00 p.m., July 25, 2019 for the Culver Street Pavement Rehabilitation Project by soliciting bids in accordance with the City of Colfax City Code and other applicable law.
- B. BID OPENING. On July 25, 2019 at 2:00 p.m., City representatives opened the bids for the Culver Street Pavement Rehabilitation Project and read the bids aloud.
- C. PROJECT AWARD. On \_\_\_\_\_, the City Council awarded the **Culver Street Pavement Rehabilitation Project** to the Contractor and directed City staff to send the Contractor written notice of award of the project. The City Council conditioned award of the project on the Contractor’s providing executed copies of all documents specified in the contract check list included in the bid package within ten (10) working days of date of written notice of award of the project.
- D. REQUIRED DOCUMENTS. The Contractor has provided the City executed copies of all documents specified in the contract check list included in the bid package within ten (10) working days of date of written notice of award.

AGREEMENT TERMS

The City and the Contractor agree as follows:

- 1. THE WORK. The Contractor shall furnish all equipment, tools, apparatus, facilities, material labor, and skill necessary to perform and complete in a good and workmanlike manner the **Culver Street Pavement Rehabilitation Project** (“Work”) as shown in the Technical Specifications and Project Plans in accordance with the Contract Documents and applicable law.
- 2. LOCATION OF WORK. The Work will be performed at the following location:  
Rising Sun Road between Newman Street and W. Oak Street in Colfax, California
- 3. TIME FOR COMPLETION. The Contractor must complete the Work in accordance with the Contract Documents within thirty (30) working days from the date specified in the City’s Notice to Proceed (“Time for Completion”).
- 4. REMEDIES FOR FAILURE TO TIMELY COMPLETE THE WORK. If the Contractor fails to fully perform the Work in accordance with the Contract Documents by the Time for Completion, as such time may be amended by change order or other modification to this Agreement in accordance with its terms, and/or if the Contractor fails, by the Time for Completion, to fully perform all of the Contractor’s obligations under this Agreement that have accrued by the Time for Completion, the Contractor will become liable to the City for all

resulting loss and damage in accordance with the Contract Documents and applicable law. The City's remedies for the Contractor's failure to perform include, but are not limited to, assessment of liquidated damages of **\$1,000 per day** in accordance with California Government Code Section 53069.85 and Section 5-1.02 of the General Provisions, and/or obtaining or providing for substitute performance in accordance with the Contract Documents.

5. TERMINATION. In accordance with 2 CFR Part 200, the CITY may suspend or terminate this Agreement, in whole or in part, if the CONTRACTOR materially fails to comply with any term of this Agreement, or with any of the rules, regulations or provisions referred to herein; and the CITY may declare the CONTRACTOR ineligible for any further participation in the CITY's contracts, in addition to other remedies as provided by law. In the event there is probable cause to believe the CONTRACTOR is in noncompliance with any applicable rules or regulations, the CITY may withhold up to fifteen (15) percent of said contract funds until such time as the CONTRACTOR is found to be in compliance by the CITY, or is otherwise adjudicated to be in compliance.
6. CONTRACT PRICE AND PAYMENT. As full compensation in consideration of completion of the Work in accordance with the Contract Documents and in consideration of the fulfillment of all of the Contractor's obligations under the Contract Documents, the City will pay the Contractor in lawful money of the United States the total price of \$      **In Bold** \_\_\_\_\_ (the "Contract Price") as specified in the Contractor's completed Bid Schedule dated \_\_\_\_\_, \_\_\_\_\_, and attached hereto and incorporated in this Agreement. Payment to the Contractor under this Agreement will be for Work actually performed in accordance with the Contract Documents and will be made in accordance with the requirements of the Contract Documents and applicable law. The City will have no obligation to pay the Contractor any amount in excess of the Contract Price unless this Agreement is first modified in accordance with its terms. The City's obligation to pay the Contractor under this Agreement is subject to and may be offset by charges that may apply to the Contractor under this Agreement. Such charges include but are not limited to, charges for liquidated damages and/or substitute performance in accordance with the Contract Documents.
7. PREVAILING WAGES. In accordance with California Labor Code Section 1771, not less than the general prevailing rate of per diem wages for work of a similar character in the locality in which the Work is to be performed, and not less than the general prevailing rate of per diem wages for holiday and overtime work fixed as provided in the California Labor Code must be paid to all workers engaged in performing the Work. In accordance with California Labor Code Section 1770 and following, the Director of Industrial Relations has determined the general prevailing wage per diem rates for the locality in which the Work is to be performed. In accordance with California Labor Code Section 1773, the City has obtained the general prevailing rate of per diem wages and the general rate for holiday and overtime work in the locality in which the Work is to be performed for each craft, classification or type of worker needed to perform the project. In accordance with California Labor Code Section 1773.2, copies of the prevailing rate of per diem wages are on file at the Office of the City Clerk and will be made available on request. Throughout the performance of the Work the Contractor must comply with all provisions of the Contract Documents and all applicable laws and regulations that apply to wages earned in performance of the Work.
8. THE CONTRACT DOCUMENTS. This Agreement consists of the following documents ("Contract Documents"), all of which are incorporated into and made a part of this Agreement

as if set forth in full. In the event of a conflict between or among the Contract Documents, precedence will be in the following order:

- 8.1 This Agreement and change orders and other amendments to this Agreement signed by authorized representatives of the City and the Contractor.
- 8.2 The General Provisions and change orders and other amendments to the General Conditions signed by authorized representatives of the City and the Contractor.
- 8.3 The Special Provisions, addenda to the Special Provisions signed by authorized representatives of the City and issued prior to bid opening, Equal Product Proposals accepted by the City and signed by authorized City representatives prior to bid opening, and change orders and other amendments to the Technical Specifications signed by authorized representatives of the City and the Contractor.
- 8.4 The Project Plans, addenda to the Project Plans signed by authorized representatives of the City and issued prior to bid opening, Equal Product Proposals accepted by the City and signed by authorized City representatives prior to bid opening, and change orders and other amendments to the Project Plans signed by authorized representatives of the City and the Contractor.
- 8.5 Notice Inviting Bids.
- 8.6 Instructions to Bidders.
- 8.7 The successful bidder's completed Proposal Form and Bidder's Sheet.
- 8.8 The successful bidder's completed Contractor License Information.
- 8.9 The successful bidder's completed List of Proposed Subcontractors.
- 8.10 The successful bidder's Workers Compensation Insurance Certification.
- 8.11 The successful bidder's completed Non-Collusion Declaration.
- 8.12 The successful bidder's Debarment Certification.
- 8.13 The successful bidder's completed Certificates of Insurance and Endorsements.
- 8.14 The successful bidder's executed Performance Bond.
- 8.15 The successful bidder's executed Payment Bond.
- 8.16 Executed Escrow for Deposit Agreement, if applicable.
- 8.17 Change Order Form.



8.18 The Maintenance Bond form included in the bid package that the Contractor must execute prior to release of final payment under the Contract.

8.19 The successful bidder's Qualification Statement, if any.

8.20 The successful bidder's signed Signature Form.

8.21 Attachment A.

8. PROVISIONS INCORPORATED BY REFERENCE. Provisions or parts of provisions that are incorporated by reference and not set forth at length in any of the Contract Documents will only form a part of this Agreement to the extent the Contract Documents expressly make such provisions or parts of provisions a part of this Agreement. For example, published public works agreement provisions, such as those of the State of California Department of Transportation Standard Specifications (known as the Standard Specifications) are only a part of this Agreement to the extent expressly incorporated in this Agreement by section number, and references in the Standard Specifications incorporated by reference to other Standard Specifications do not make such other Standard Specifications a part of this Agreement. When such published provisions are made a part of this Agreement, references in the published provisions to other entities, such as the State, the Agency, or similar references, will be deemed references to the City as the context of this Agreement may require.

9. INTERPRETATION OF CONTRACT DOCUMENTS. Any question concerning the intent or meaning of any provision of the Contract Documents, including, but not limited to, the Technical Specifications or Project Plans, must be submitted to the City Engineer, for issuance of an interpretation and/or decision by an authorized City Engineer representative in accordance with the requirements of the Contract Documents. Interpretations or decisions by any other person concerning the Contract Documents will not be binding on the City. The decision of an authorized City Engineer representative shall be final.

10. ASSIGNMENT PROHIBITED. The Contractor may not assign part or all of this Agreement, or any moneys due or to become under this Agreement, or any other right or interest of the Contractor under this Agreement, or delegate any obligation or duty of the Contractor under this Agreement without the prior written approval of an official authorized to bind the City and an authorized representative of Contractor's surety or sureties. Any such purported assignment or delegation without such written approval on behalf of the City and the Contractor's sureties will be void and a material breach of this agreement subject to all available remedies under this Agreement and at law and equity.

11. CERTIFICATION RE CONTRACTOR'S LICENSE. By signing this Agreement the Contractor certifies that the Contractor holds a valid Type A license issued by the California State Contractors Licensing Board, and that the Contractor understands that failure to maintain its license in good standing throughout the performance of the Work may result in discipline and/or other penalties pursuant to the California Business and Professions Code, and may constitute a material breach of this Agreement subject to all available remedies under this agreement and at law and equity.

- 12. SEVERABILITY. If any term or provision or portion of a term or provision of this Agreement is declared invalid or unenforceable by any court of lawful jurisdiction, then the remaining terms and provisions or portions of terms or provisions will not be affected thereby and will remain in full force and effect.
  
- 13. DEFINITIONS. All words as used in the Agreement shall be subject to the Definitions set forth in Section 1 of the General Provisions of the Notice to Contractors, Special Provisions, Proposal and Contract for the Culver Street Pavement Rehabilitation Project.

IN WITNESS WHEREOF, the parties have executed this Contract at Colfax, California, the day and year first above written.

CITY OF COLFAX

Name of Contractor

\_\_\_\_\_  
By: William Stockwin, Mayor

\_\_\_\_\_  
Name of Signatory & Title

Attest:

\_\_\_\_\_  
Lorraine Cassidy, City Clerk

Approved as to Form and Legality:

\_\_\_\_\_  
Alfred Cabral, City Attorney

**PERFORMANCE BOND**

*(NOTE: Bidders must use this form, use of any other bond form may render a bid non-responsive)*

KNOW ALL MEN BY THESE PRESENTS:

WHEREAS the City Council of the City of Colfax has awarded to \_\_\_\_\_ (designated as the "PRINCIPAL") a contract for the **Culver Street Pavement Rehabilitation Project**, which contract and all of the contract documents as defined therein (designated as the "Contract") are hereby made a part hereof; and

WHEREAS, said PRINCIPAL is required under the terms of the Contract to furnish a bond for the faithful performance of the Contract;

NOW, THEREFORE, WE, the PRINCIPAL and \_\_\_\_\_ as surety (designated as "SURETY"), an admitted surety insurer authorized to do business in the State of California, are held and firmly bound unto the City (designated as "OBLIGEE"), in the penal sum of \_\_\_\_\_ dollars (\$ \_\_\_\_\_), lawful money of the United States for the payment of which sum well and truly to be made, we bind ourselves, our heirs, executors, and administrators, and successors, jointly and severally, firmly by these presents.

THE CONDITION OF THIS OBLIGATION IS SUCH that, if the above bound PRINCIPAL, his or its heirs, executors, administrators, successors, or assigns, shall in all things stand to and abide by, and well and truly keep and perform the covenants, conditions and agreements in the Contract and any alteration thereof made as therein provided, on his or their part to be kept and performed at the time and in the manner therein specified and in all respects according to their true intent and meaning, and shall defend, indemnify and save harmless the OBLIGEE, it's officials, officers, employees, volunteers and agents, as therein stipulated, then this obligation shall become null and void, otherwise it shall be and remain in full force and virtue.

And the said SURETY, for value received, hereby stipulates and agrees that no change, extension of time, alteration or addition to the terms of the Contract or to the work to be performed thereunder or to the specifications or the plans accompanying the same or to any other part of the contract documents, as defined therein, shall in any way affect said SURETY's obligation on this bond, and the SURETY does hereby waive notice of any such change, extension of time, alteration or addition.

And the said SURETY, for value received, hereby stipulates and agrees that upon termination of the Contract for cause, the OBLIGEE reserves the right to refuse tender of the PRINCIPAL by the SURETY to complete the Contract work.

IN WITNESS WHEREOF, the above-bound parties have executed this instrument under their several seals this \_\_\_\_\_ day of \_\_\_\_\_, \_\_\_\_\_, the name and corporate seals of each corporate party being hereto affixed and these presents duly signed by their undersigned representatives, pursuant to authority of their governing bodies.

(Corporate Seal) PRINCIPAL \_\_\_\_\_

By \_\_\_\_\_

(Acknowledgment) Title \_\_\_\_\_

(Corporate Seal) SURETY \_\_\_\_\_

By \_\_\_\_\_  
(Attorneys-in-fact)

(Acknowledgment) Title \_\_\_\_\_

*(NOTE TO SURETY COMPANY: A certified copy of unrevoked resolution of authority for the attorney-in-fact must be submitted with and attached to the executed bond.)*

**PAYMENT/LABOR AND MATERIALS BOND**

*(NOTE: Bidders must use this form, use of any other bond form may render a bid non-responsive)*

KNOW ALL MEN BY THESE PRESENTS:

WHEREAS the City Council of the City of Colfax has awarded to \_\_\_\_\_ (designated as the "PRINCIPAL") a contract for the **Culver Street Pavement Rehabilitation Project**, which contract and all of the contract documents as defined therein (designated as the "Contract") are hereby made a part hereof; and

WHEREAS, pursuant to California Civil Code Section 9550, the PRINCIPAL is required, before entering upon the performance of the Contract, to file a payment bond with and have such bond approved by the officer or public entity by whom the Contract is awarded; and

WHEREAS, pursuant to California Civil Code Section 9554, such payment bond must be in a sum not less than one hundred percent (100%) of the total amount payable by the terms of the Contract, and must satisfy the other requirements specified in that section; and

WHEREAS, the PRINCIPAL is required in accordance with the Contract to furnish a payment bond in connection with the Contract to secure payment of claims of laborers, mechanics and materialmen employed on work under the Contract in accordance with applicable law;

NOW, THEREFORE, THESE PRESENTS WITNESSETH:

That the PRINCIPAL and the undersigned \_\_\_\_\_, as surety (designated as "SURETY"), an admitted surety insurer authorized to do business in the State of California are held and firmly bound unto all laborers, material men, and all other persons named in California Civil Code Section 9100 in the sum of \_\_\_\_\_ Dollars (\$ \_\_\_\_\_), lawful money of the United States, being a sum not less than one hundred percent of the total amount payable by the terms of the Contract, for the payment of which sum well and truly to be made, we bind ourselves, our heirs, executors, administrators, successors, or assigns, jointly and severally, by these presents.

THE CONDITION OF THIS OBLIGATION IS SUCH that if the PRINCIPAL or any of the PRINCIPAL's subcontractors, or the heirs, executors, administrators, successors, or assigns of any, all, or either of them, shall fail to pay any persons named in California Civil Code Section 9100, or fail to pay for any labor, materials, provisions, provender, or other supplies used in, upon, for or about the performance of the work contracted to be done, or for any work or labor thereon of any kind, or fail to pay amounts due under the Unemployment Insurance Code with respect to such work or labor, or fail to pay for any amounts required to be deducted, withheld, and paid over to the Employment Development Department from the wages of employees of the PRINCIPAL or any subcontractors of the PRINCIPAL pursuant to Section 13020 of the Unemployment Insurance Code with respect to such work or labor, that the SURETY will pay for the same in an amount not exceeding the amount herein above set forth, and also, in case suit is brought upon this bond, will pay a reasonable attorney's fee to be awarded and fixed by the Court; otherwise this obligation shall be void.

It is hereby expressly stipulated and agreed by the said Surety, for value received, that this bond shall inure to the benefit of any and all of the persons named in Section 9100 of the California Civil Code so as to give a right of action to them or their assigns in any suit brought upon this bond.

It is hereby further expressly stipulated and agreed by the said Surety, for value received, that no change, extension of time, alteration or addition to the terms of the Contract or the specifications or drawings accompanying the same or to any other part of the contract documents, as defined therein, shall in any manner affect the obligations of the SURETY on this bond, and SURETY does hereby waive notice of any such change, extension, alteration, or addition.

IN WITNESS WHEREOF, the above-bound parties have executed this instrument under their several seals this \_\_\_\_\_ day of \_\_\_\_\_, \_\_\_\_\_, the name and corporate seals of each corporate party being hereto affixed and these presents duly signed by their undersigned representatives, pursuant to authority of their governing bodies.

(Corporate Seal) PRINCIPAL \_\_\_\_\_

By \_\_\_\_\_

(Acknowledgment) Title \_\_\_\_\_

(Corporate Seal) SURETY \_\_\_\_\_

By \_\_\_\_\_  
(Attorneys-in-fact)

(Acknowledgment) Title \_\_\_\_\_

*(NOTE TO SURETY COMPANY: A certified copy of unrevoked resolution of authority for the attorney-in-fact must be submitted with and attached to the executed bond.)*

CITY OF COLFAX  
33 South Main Street, P.O. Box 702 Colfax, California 95713

ORDER NO
DATE
STATE California
COUNTY Placer

**CONTRACT CHANGE ORDER**

**CONTRACT FOR:**  
**CONTRACT NO:**  
**OWNER:** City of Colfax  
**CONTRACTOR:**  
**CURRENT CONTRACT PRICE:**  
**CURRENT CONTRACT TIME OF COMPLETION:**  
**CURRENT NO. WORKING DAYS:**

**TO:** \_\_\_\_\_  
(Contractor)

You are hereby requested to comply with the following changes from to the contract plans, specifications, or other contract documents:

Description of Changes (Supplemental Plans and Specifications Attached)	DECREASE in Contract Price	INCREASE In Contract Price
1)		
TOTALS	\$ -	\$ -
NET CHANGE IN CONTRACT PRICE		\$ 0.00

**JUSTIFICATION:**

The amount of the Contract will be (Decreased) (Increased) By The Sum Of: \$ -

The Contract Total Including this and previous Change Orders Will Be:

The Contract Period Provided for Completion Will Be (Increased) (Decreased) (Unchanged): \_\_\_\_\_ Days  
Contract Completion Date

Upon execution by representatives authorized to bind the parties, this Change Order will become a part of the contract. The consideration specified in this Change Order (whether an adjustment of the contract price, an adjustment of time, and/or other consideration) is the full and sole compensation owed to the contractor as a result of the changes and issues described in this Change Order. Such consideration includes, but is not limited to, any and all direct and indirect costs incurred by the contractor as a result of the changes and issues described in this Change Order for any labor, equipment, materials, overhead (additional, extended, field and home office), profit, or time adjustments. By signing this Change Order the contractor waives and releases the owner from any and all claims for additional compensation concerning any of the changes and issues specified in this Change Order.

The undersigned, being the \_\_\_\_\_ (Title) of the Contractor, by signing this Changer Order declares under penalty of perjury under the laws of the State of California, and does personally certify and attest that: the undersigned has thoroughly reviewed the attached request for change order and knows its contents, and said request for change order is made in good faith; that it is supported by truthful and accurate data; that the amount requested and the additional time requested accurately reflect the allowable expenses that would be incurred, and the time necessary, to perform the change order; and further, that the undersigned is familiar with California Penal Code Section 72 and California Government Code Section 12650 et seq., pertaining to false claims, and further knows and understands that the submission or certification of a false claim may lead to fines, imprisonment, or other severe legal consequences.

Requested \_\_\_\_\_ (Owner) (Date)

Recommended \_\_\_\_\_ (Owner's Architect/Engineer) (Date)

Accepted \_\_\_\_\_ (Contractor) (Date)

Approved by Agency \_\_\_\_\_ (Name and Title) (Date)

925984



**MAINTENANCE BOND**

*(NOTE: Bidders must use this form, use of any other bond form may render a bid non-responsive)*

KNOW ALL MEN BY THESE PRESENTS:

WHEREAS the City Council of the City of Colfax has awarded to \_\_\_\_\_ (designated as the "PRINCIPAL") a contract for the **Culver Street Pavement Rehabilitation Project**, which contract and all of the contract documents as defined therein (designated as the "Contract") are hereby made a part hereof; and

WHEREAS, the PRINCIPAL is required under the terms of the Contract to furnish a bond for the correction of any defects due to defective materials or workmanship in the work performed under the Contract.

NOW, THEREFORE, we the PRINCIPAL and the undersigned \_\_\_\_\_, as surety (designated as "SURETY"), an admitted surety insurer authorized to do business in the State of California, are held and firmly bound unto the City of Colfax, (designated as the "OBLIGEE"), in the penal sum of \_\_\_\_\_ Dollars (\$ \_\_\_\_\_), lawful money of the United States, being a sum not less than ten percent (10%) of the final Contract price, for the payment of which sum well and truly to be made, we bind ourselves, our heirs, executors, administrators, successors, and assigns jointly and severally, firmly by these presents.

THE CONDITIONS OF THIS OBLIGATION ARE SUCH that if, during a maintenance period of one (1) year from the date of acceptance by the OBLIGEE of the contracted work, the PRINCIPAL upon receiving written notice of a need for repairs which are directly attributable to defective materials or workmanship, shall diligently take the necessary steps to correct said defects within seven (7) days from the date of said notice, then this obligation shall be null and void; otherwise it shall remain in full force and effect.

If any action shall be brought by the OBLIGEE upon this bond, a reasonable attorney's fee, to be fixed by the Court, shall be and become a part of OBLIGEE's judgment in any such action.

No right of action shall accrue on this bond to, or for the use of, any person or corporation other than the OBLIGEE named herein or the heirs, executors, administrator or successor of the OBLIGEE.

IN WITNESS WHEREOF, the above bound parties have executed this instrument under their seals this \_\_\_\_\_ day of \_\_\_\_\_, the name and corporate seals of each corporate party being hereto affixed and these presents duly signed by its undersigned representative, pursuant to authority of its governing body.

(Corporate Seal) PRINCIPAL \_\_\_\_\_

By \_\_\_\_\_

(Acknowledgment) Title \_\_\_\_\_

(Corporate Seal) SURETY \_\_\_\_\_

By \_\_\_\_\_  
(Attorneys-in-fact)

(Acknowledgment) Title \_\_\_\_\_

*(NOTE TO SURETY COMPANY: A certified copy of unrevoked resolution of authority for the attorney-in-fact must be submitted with and attached to the executed bond.)*

**ESCROW AGREEMENT FOR  
SECURITY DEPOSITS IN LIEU OF RETENTION**

This Escrow Agreement is made and entered into by and between the City of Colfax, whose address is 33 South Main Street, P.O. Box 702 Colfax, California 95713 hereinafter called "City", and \_\_\_\_\_, whose address is \_\_\_\_\_, hereinafter called "Contractor", and \_\_\_\_\_, whose address is \_\_\_\_\_, hereinafter called "Escrow Agent"

For consideration hereinafter set forth, the City, Contractor, and Escrow Agent agree as follows:

1. Pursuant to Section 22300 of the Public Contract Code of the State of California, Contractor has the option to deposit securities with Escrow Agent as a substitute for retention earnings required to be withheld by City pursuant to the Construction Contract entered into between the City and Contractor for the project entitled **Culver Street Pavement Rehabilitation Project** in the amount of \_\_\_\_\_ dated \_\_\_\_\_ (hereinafter referred to as the "Contract"). Alternatively, on written request of the Contractor, the City shall make payments of the retention earnings directly to the Escrow Agent. When Contractor deposits the securities as substitute for Contract earnings, the Escrow Agent shall notify the City within 10 days of the deposit. The market value of the securities at the time of the substitution shall be at least equal to the cash amount then required to be withheld as retention under the terms of the Contract between the City and Contractor. Securities shall be held in the name of \_\_\_\_\_ and shall designate the Contractor as the beneficial owner.
2. The City shall make progress payments to the Contractor for such funds which otherwise would be withheld from progress payments pursuant to the Contract provisions, provided that the Escrow Agent holds securities in the form and amount specified above.
3. When the City makes payment of retentions earned directly to the Escrow Agent, the Escrow Agent shall hold them for the benefit of the Contractor until such time as the escrow created under this contract is terminated. The Contractor may direct the investments of the payments into securities. All terms and conditions of this agreement and the rights and responsibilities of the parties shall be equally applicable and binding when the City pays the escrow agent directly.
4. Contractor shall be responsible for paying all fees for the expenses incurred by Escrow Agent in administering the Escrow Account and all expenses of the City. These expenses and payment terms shall be determined by the City, Contractor and Escrow Agent.
5. The interest earned on the securities or the money market accounts held in escrow and all interest earned on that interest shall be for the sole account of the Contractor and shall be subject to withdrawal by Contractor at any time and from time to time without notice to the City.
6. Contractor shall have the right to withdraw all or any part of the principal in the Escrow Account only by written notice to Escrow Agent accompanied by written authorization from City to the Escrow Agent that City consents to the withdrawal of the amount sought to be withdrawn by Contractor.

- 7. The City shall have a right to draw upon the securities in the event of default by the Contractor. Upon seven day's written notice to the Escrow Agent from the City of the default, the Escrow Agent shall immediately convert the securities to cash and shall distribute the cash as instructed by the City.
- 8. Upon receipt of written notification from the City certifying that the Contract is final and complete, and that the Contractor has complied with all requirements and procedures applicable to the Contract, Escrow Agent shall release to Contractor all securities and interest on deposit less escrow fees and charges of the Escrow Account. The escrow shall be closed immediately upon disbursement of all monies and securities on deposit and payments of fees and charges.
- 9. Escrow Agent shall rely on the written notifications from the City and the Contractor pursuant to Sections (4) to (6) inclusive, of this agreement and the City and Contractor shall hold Escrow Agent harmless from Escrow Agent's release and disbursement of the securities and interest as set forth above.
- 10. The names of the persons who are authorized to give written notice or to receive written notice on behalf of the City and on behalf of Contractor in connection with the foregoing, and exemplars of their respective signatures, are as follows:

On behalf of City:

\_\_\_\_\_

Title: \_\_\_\_\_

Name: \_\_\_\_\_

On Behalf of Contractor:

\_\_\_\_\_

Title: \_\_\_\_\_

Name: \_\_\_\_\_

On behalf of Escrow Agent:

\_\_\_\_\_

\_\_\_\_\_

Title

\_\_\_\_\_

Name

\_\_\_\_\_

Signature

\_\_\_\_\_

Address

At the time the Escrow Account is opened, the City and Contractor shall deliver to the Escrow Agent a fully executed counterpart of this Agreement.

IN WITNESS WHEREOF, the parties have executed this Agreement by their proper officers on the date first set forth above.

City:

Contractor:

\_\_\_\_\_  
Title

\_\_\_\_\_  
Title

\_\_\_\_\_  
Name

\_\_\_\_\_  
Name

\_\_\_\_\_  
Signature

\_\_\_\_\_  
Signature

\_\_\_\_\_  
Address

\_\_\_\_\_  
Address



# CITY of COLFAX

C A L I F O R N I A

CITY HALL, 33 SOUTH MAIN STREET, COLFAX, CA



## BUSINESS LICENSE APPLICATION

**BUSINESS INFORMATION**

**Business Name**

\_\_\_\_\_

**DBA / Corporate Name**

\_\_\_\_\_

**Business Address**

\_\_\_\_\_

17538.5)

(Cannot be PO Box per State of California Business & Professionals Code – Section

**Mailing Address**

\_\_\_\_\_

**Phone Number**

\_\_\_\_\_

**Email Address**

\_\_\_\_\_

**Description of Business**

\_\_\_\_\_

\_\_\_\_\_

**Type of Ownership:**    Corporation    LLC    Partnership    Sole Proprietor    Trust    Non-Profit

.....

**PERSONAL INFORMATION**

– Enter below names of Owners, Partners, or Corporate Officers (Attach additional sheet(s) if necessary)

**1<sup>st</sup>**

**Owner/Principal**

\_\_\_\_\_

\_\_\_\_\_

**Title**

\_\_\_\_\_

\_\_\_\_\_

**Home Address**

\_\_\_\_\_

(Cannot be a PO Box)

City

Zip Code

Bus. Start Date	
State Sales Tax No.	
Federal Tax ID No.	
State Lic. Type	
State Lic. No.	
Expire Date	

Home Phone Number	
Cell Phone Number	

2<sup>nd</sup>  
 Owner/Principal \_\_\_\_\_

Home Phone Number	_____
Cell Phone Number	_____

Title \_\_\_\_\_

Home Address \_\_\_\_\_  
(Cannot be a PO Box) City Zip Code

**IF YOUR BUSINESS IS LOCATED IN THE CITY OF COLFAX:**

**YES**

**NO**

1. Is the building newly constructed?.....
2. Are you making any modifications to the building that would require a permit?.....    
 (e.g. new signs, additions, tenant improvements (electrical, plumbing, etc.)  
 \*If yes, have you submitted application(s) for permit(s)?.....
3. Is this a home business?.....

*\*Please complete application on the back\**

Please enter all that apply to this business/rental		CERTIFICATION AND ACKNOWLEDEMENT
No. of Owners / Employees	#	I declare under penalty and perjury that the statements made in this application are true. I further agree that business shall be conducted in accordance with the City of Colfax Municipal Code. I understand that Sales or Use Tax may apply to my business activities. Upon issuance of a business license, it shall be my responsibility to renew the license annually by June 30 <sup>th</sup> .  Owner/Principal Signature _____  Title _____ Date _____
Estimated Current Year Annual Gross Receipts for Sales and/or Services	\$	
No. of Residential Rental Units	#	

OFFICE USE ONLY	
ANNUAL FEE \$	FEE BASIS
PRORATED FEE \$	DATE RECEIVED
*A.D.A. FEE \$ 4.00	LICENSE EXPIRES
TOTAL FEES PAID \$	ACCEPTED BY
PAYMENT BY: Check # _____ \$ _____ CASH \$ _____ CREDIT CARD \$ _____	
*Senate Bill 1186 (Chapter 383, Statues of 2012, Steinberg) requires an additional fee of one dollar (\$1) to be paid by any person(s) applying for a local business license, or equivalent instrument, or permit, and any applicant renewing a business license, or equivalent instrument, or permit.	

APPLICATION APPROVED BY	
City Manager	Date
City Building Official	Date
City Planner	Date
City Engineer (If Required)	Date

If you **do NOT have employees** and do NOT carry Workers' Compensation Insurance, please sign below.

**AFFIDAVIT OF WORKERS' COMPENSATION EXEMPTION**

I certify that, in the performance of work for which this license is issued, I shall not employ any person in any manner so as to become subject to the Workers' Compensation laws of California.

Owner's Signature \_\_\_\_\_ Date \_\_\_\_\_

Sales or use tax may apply to your business activities. You may seek written advice regarding the application of tax to your particular business by writing to the nearest State Board of Equalization office.  
For general information, please call the Board of Equalization at 1-800-400-7115.

---

**STATE OF CALIFORNIA DISABILITY ACCESS FEE**

Under federal and state law, compliance with disability access laws is a serious and significant responsibility that applies to all California building owners and tenants with buildings open to the public. You may obtain information about your legal obligations and how to comply with disability access laws at the following agencies:

The Division of the State Architect at [www.dgs.ca.gov/dsa/Home.aspx](http://www.dgs.ca.gov/dsa/Home.aspx).

The Department of Rehabilitation at [www.rehab.cahwnet.gov](http://www.rehab.cahwnet.gov).

The California Commission on Disability Access at [www.cdda.ca.gov](http://www.cdda.ca.gov).

---

**Mail completed form and check made payable to the "City of Colfax" at address below.**

**PLEASE NOTE: Cash or Checks Accepted Only**

**City of Colfax  
City Clerk's Office  
33 South Main Street  
P.O. Box 702  
Colfax, CA 95713**

(530) 346-2313

FAX: (530) 346-6214



Form **W-9**  
(Rev. November 2005)  
Department of the Treasury  
Internal Revenue Service

**Request for Taxpayer  
Identification Number and Certification**

**Give form to the  
requester. Do not  
send to the IRS.**

Print or type  
See Specific Instructions on page 2.

Name (as shown on your income tax return)	
Business name, if different from above	
Check appropriate box: <input type="checkbox"/> Individual/ Sole proprietor <input type="checkbox"/> Corporation <input type="checkbox"/> Partnership <input type="checkbox"/> Other ▶ .....	<input type="checkbox"/> Exempt from backup withholding
Address (number, street, and apt. or suite no.)	Requester's name and address (optional)
City, state, and ZIP code	
List account number(s) here (optional)	

**Part I Taxpayer Identification Number (TIN)**

Enter your TIN in the appropriate box. The TIN provided must match the name given on Line 1 to avoid backup withholding. For individuals, this is your social security number (SSN). However, for a resident alien, sole proprietor, or disregarded entity, see the Part I instructions on page 3. For other entities, it is your employer identification number (EIN). If you do not have a number, see *How to get a TIN* on page 3.

**Note:** If the account is in more than one name, see the chart on page 4 for guidelines on whose number to enter.

<b>Social security number</b>								
<b>or</b>								
<b>Employer identification number</b>								

**Part II Certification**

Under penalties of perjury, I certify that:

1. The number shown on this form is my correct taxpayer identification number (or I am waiting for a number to be issued to me), and
2. I am not subject to backup withholding because: (a) I am exempt from backup withholding, or (b) I have not been notified by the Internal Revenue Service (IRS) that I am subject to backup withholding as a result of a failure to report all interest or dividends, or (c) the IRS has notified me that I am no longer subject to backup withholding, and
3. I am a U.S. person (including a U.S. resident alien).

**Certification instructions.** You must cross out item 2 above if you have been notified by the IRS that you are currently subject to backup withholding because you have failed to report all interest and dividends on your tax return. For real estate transactions, item 2 does not apply. For mortgage interest paid, acquisition or abandonment of secured property, cancellation of debt, contributions to an individual retirement arrangement (IRA), and generally, payments other than interest and dividends, you are not required to sign the Certification, but you must provide your correct TIN. (See the instructions on page 4.)

**Sign Here**

Signature of  
U.S. person ▶

Date ▶

**Purpose of Form**

A person who is required to file an information return with the IRS, must obtain your correct taxpayer identification number (TIN) to report, for example, income paid to you, real estate transactions, mortgage interest you paid, acquisition or abandonment of secured property, cancellation of debt, or contributions you made to an IRA.

**U.S. person.** Use Form W-9 only if you are a U.S. person (including a resident alien), to provide your correct TIN to the person requesting it (the requester) and, when applicable, to:

1. Certify that the TIN you are giving is correct (or you are waiting for a number to be issued),
2. Certify that you are not subject to backup withholding, or
3. Claim exemption from backup withholding if you are a U.S. exempt payee.

In 3 above, if applicable, you are also certifying that as a U.S. person, your allocable share of any partnership income from a U.S. trade or business is not subject to the withholding tax on foreign partners' share of effectively connected income.

- An individual who is a citizen or resident of the United States,
- A partnership, corporation, company, or association created or organized in the United States or under the laws of the United States, or
- Any estate (other than a foreign estate) or trust. See Regulations sections 301.7701-6(a) and 7(a) for additional information.

**Special rules for partnerships.** Partnerships that conduct a trade or business in the United States are generally required to pay a withholding tax on any foreign partners' share of income from such business. Further, in certain cases where a Form W-9 has not been received, a partnership is required to presume that a partner is a foreign person, and pay the withholding tax. Therefore, if you are a U.S. person that is a partner in a partnership conducting a trade or business in the United States, provide Form W-9 to the partnership to establish your U.S. status and avoid withholding on your share of partnership income.

The person who gives Form W-9 to the partnership for purposes of establishing its U.S. status and avoiding

**Note.** If a requester gives you a form other than Form W-9 to request your TIN, you must use the requester's form if it is substantially similar to this Form W-9.

For federal tax purposes, you are considered a person if you are:

withholding on its allocable share of net income from the partnership conducting a trade or business in the United States is in the following cases:

- The U.S. owner of a disregarded entity and not the entity,

Cat. No. 10231X

Form **W-9** (Rev. 11-2005)

Page **2**

Form W-9 (Rev. 11-2005)

- The U.S. grantor or other owner of a grantor trust and not the trust, and
- The U.S. trust (other than a grantor trust) and not the beneficiaries of the trust.

**Foreign person.** If you are a foreign person, do not use Form W-9. Instead, use the appropriate Form W-8 (see Publication 515, Withholding of Tax on Nonresident Aliens and Foreign Entities).

**Nonresident alien who becomes a resident alien.**

Generally, only a nonresident alien individual may use the terms of a tax treaty to reduce or eliminate U.S. tax on certain types of income. However, most tax treaties contain a provision known as a "saving clause." Exceptions specified in the saving clause may permit an exemption from tax to continue for certain types of income even after the recipient has otherwise become a U.S. resident alien for tax purposes.

If you are a U.S. resident alien who is relying on an exception contained in the saving clause of a tax treaty to claim an exemption from U.S. tax on certain types of income, you must attach a statement to Form W-9 that specifies the following five items:

1. The treaty country. Generally, this must be the same treaty under which you claimed exemption from tax as a nonresident alien.
2. The treaty article addressing the income.
3. The article number (or location) in the tax treaty that contains the saving clause and its exceptions.
4. The type and amount of income that qualifies for the exemption from tax.
5. Sufficient facts to justify the exemption from tax under the terms of the treaty article.

**Example.** Article 20 of the U.S.-China income tax treaty allows an exemption from tax for scholarship income received by a Chinese student temporarily present in the United States. Under U.S. law, this student will become a resident alien for tax purposes if his or her stay in the United States exceeds 5 calendar years. However, paragraph 2 of the first Protocol to the U.S.-China treaty (dated April 30, 1984) allows the provisions of Article 20 to continue to apply even after the Chinese student becomes a resident alien of the United States. A Chinese student who qualifies for this exception (under paragraph 2 of the first protocol) and is relying on this exception to claim an exemption from tax on his or her scholarship or fellowship income would attach to Form W-9 a statement that includes the information described above to support that exemption.

If you are a nonresident alien or a foreign entity not subject to backup withholding, give the requester the appropriate completed Form W-8.

**What is backup withholding?** Persons making certain payments to you must under certain conditions withhold and pay to the IRS 28% of such payments (after December 31, 2002). This is called "backup withholding." Payments that may be subject to backup withholding include interest, dividends, broker and barter exchange transactions, rents, royalties, nonemployee pay, and certain payments from fishing boat operators. Real estate transactions are not subject to backup withholding.

You will not be subject to backup withholding on payments

3. The IRS tells the requester that you furnished an incorrect TIN,

4. The IRS tells you that you are subject to backup withholding because you did not report all your interest and dividends on your tax return (for reportable interest and dividends only), or

5. You do not certify to the requester that you are not subject to backup withholding under 4 above (for reportable interest and dividend accounts opened after 1983 only).

Certain payees and payments are exempt from backup withholding. See the instructions below and the separate Instructions for the Requester of Form W-9.

Also see *Special rules regarding partnerships* on page 1.

## Penalties

**Failure to furnish TIN.** If you fail to furnish your correct TIN to a requester, you are subject to a penalty of \$50 for each such failure unless your failure is due to reasonable cause and not to willful neglect.

**Civil penalty for false information with respect to withholding.** If you make a false statement with no reasonable basis that results in no backup withholding, you are subject to a \$500 penalty.

**Criminal penalty for falsifying information.** Willfully falsifying certifications or affirmations may subject you to criminal penalties including fines and/or imprisonment.

**Misuse of TINs.** If the requester discloses or uses TINs in violation of federal law, the requester may be subject to civil and criminal penalties.

## Specific Instructions

### Name

If you are an individual, you must generally enter the name shown on your income tax return. However, if you have changed your last name, for instance, due to marriage without informing the Social Security Administration of the name change, enter your first name, the last name shown on your social security card, and your new last name.

If the account is in joint names, list first, and then circle, the name of the person or entity whose number you entered in Part I of the form.

**Sole proprietor.** Enter your individual name as shown on your income tax return on the "Name" line. You may enter your business, trade, or "doing business as (DBA)" name on the "Business name" line.

**Limited liability company (LLC).** If you are a single-member LLC (including a foreign LLC with a domestic owner) that is disregarded as an entity separate from its owner under Treasury regulations section 301.7701-3, enter the owner's name on the "Name" line. Enter the LLC's name on the "Business name" line. Check the appropriate box for your filing status (sole proprietor, corporation, etc.), then check the box for "Other" and enter "LLC" in the space provided.

**Other entities.** Enter your business name as shown on required federal tax documents on the "Name" line. This name should match the name shown on the charter or other legal document creating the entity. You may enter any business, trade, or DBA name on the "Business name" line.

you receive if you give the requester your correct TIN, make the proper certifications, and report all your taxable interest and dividends on your tax return.

**Payments you receive will be subject to backup withholding if:**

1. You do not furnish your TIN to the requester,
2. You do not certify your TIN when required (see the Part II instructions on page 4 for details),

Form W-9 (Rev. 11-2005)

Page **3**

Generally, individuals (including sole proprietors) are not exempt from backup withholding. Corporations are exempt from backup withholding for certain payments, such as interest and dividends.

**Note.** If you are exempt from backup withholding, you should still complete this form to avoid possible erroneous backup withholding.

**Exempt payees.** Backup withholding is not required on any payments made to the following payees:

1. An organization exempt from tax under section 501(a), any IRA, or a custodial account under section 403(b)(7) if the account satisfies the requirements of section 401(f)(2),
2. The United States or any of its agencies or instrumentalities,
3. A state, the District of Columbia, a possession of the United States, or any of their political subdivisions or instrumentalities,
4. A foreign government or any of its political subdivisions, agencies, or instrumentalities, or
5. An international organization or any of its agencies or instrumentalities.

Other payees that may be exempt from backup withholding include:

6. A corporation,
7. A foreign central bank of issue,
8. A dealer in securities or commodities required to register in the United States, the District of Columbia, or a possession of the United States,
9. A futures commission merchant registered with the Commodity Futures Trading Commission,
10. A real estate investment trust,
11. An entity registered at all times during the tax year under the Investment Company Act of 1940,
12. A common trust fund operated by a bank under section 584(a),
13. A financial institution,
14. A middleman known in the investment community as a nominee or custodian, or
15. A trust exempt from tax under section 664 or described in section 4947.

The chart below shows types of payments that may be exempt from backup withholding. The chart applies to the exempt recipients listed above, 1 through 15.

<b>IF the payment is for . . .</b>	<b>THEN the payment is exempt for . . .</b>
Interest and dividend payments	All exempt recipients except for 9
Broker transactions	Exempt recipients 1 through 13. Also, a person registered under the Investment Advisers Act of 1940 who regularly acts as a broker
Barter exchange transactions and patronage dividends	Exempt recipients 1 through 5

**Note.** You are requested to check the appropriate box for your status (individual/sole proprietor, corporation, etc.).

**Exempt From Backup Withholding**

If you are exempt, enter your name as described above and check the appropriate box for your status, then check the "Exempt from backup withholding" box in the line following the business name, sign and date the form.

**Part I. Taxpayer Identification Number (TIN)**

**Enter your TIN in the appropriate box.** If you are a resident alien and you do not have and are not eligible to get an SSN, your TIN is your IRS individual taxpayer identification number (ITIN). Enter it in the social security number box. If you do not have an ITIN, see *How to get a TIN* below.

If you are a sole proprietor and you have an EIN, you may enter either your SSN or EIN. However, the IRS prefers that you use your SSN.

If you are a single-owner LLC that is disregarded as an entity separate from its owner (see *Limited liability company (LLC)* on page 2), enter your SSN (or EIN, if you have one). If the LLC is a corporation, partnership, etc., enter the entity's EIN.

**Note.** See the chart on page 4 for further clarification of name and TIN combinations.

**How to get a TIN.** If you do not have a TIN, apply for one immediately. To apply for an SSN, get Form SS-5, Application for a Social Security Card, from your local Social Security Administration office or get this form online at [www.socialsecurity.gov](http://www.socialsecurity.gov). You may also get this form by calling 1-800-772-1213. Use Form W-7, Application for IRS Individual Taxpayer Identification Number, to apply for an ITIN, or Form SS-4, Application for Employer Identification Number, to apply for an EIN. You can apply for an EIN online by accessing the IRS website at [www.irs.gov/businesses](http://www.irs.gov/businesses) and clicking on Employer ID Numbers under Related Topics. You can get Forms W-7 and SS-4 from the IRS by visiting [www.irs.gov](http://www.irs.gov) or by calling 1-800-TAX-FORM (1-800-829-3676).

If you are asked to complete Form W-9 but do not have a TIN, write "Applied For" in the space for the TIN, sign and date the form, and give it to the requester. For interest and dividend payments, and certain payments made with respect to readily tradable instruments, generally you will have 60 days to get a TIN and give it to the requester before you are subject to backup withholding on payments. The 60-day rule does not apply to other types of payments. You will be subject to backup withholding on all such payments until you provide your TIN to the requester.

**Note.** Writing "Applied For" means that you have already applied for a TIN or that you intend to apply for one soon.

**Caution:** A disregarded domestic entity that has a foreign owner must use the appropriate Form W-8.

Payments over \$600 required to be reported and direct sales over \$5,000 <sup>1</sup>	Generally, exempt recipients 1 through 7
--	--

<sup>1</sup>See Form 1099-MISC, Miscellaneous Income, and its instructions.

<sup>2</sup>However, the following payments made to a corporation (including gross proceeds paid to an attorney under section 6045(f), even if the attorney is a corporation) and reportable on Form 1099-MISC are not exempt from backup withholding: medical and health care payments, attorneys' fees; and payments for services paid by a federal executive agency.

Form W-9 (Rev. 11-2005)

Page 4

## Part II. Certification

To establish to the withholding agent that you are a U.S. person, or resident alien, sign Form W-9. You may be requested to sign by the withholding agent even if items 1, 4, and 5 below indicate otherwise.

For a joint account, only the person whose TIN is shown in Part I should sign (when required). Exempt recipients, see *Exempt From Backup Withholding* on page 2.

**Signature requirements.** Complete the certification as indicated in 1 through 5 below.

**1. Interest, dividend, and barter exchange accounts opened before 1984 and broker accounts considered active during 1983.** You must give your correct TIN, but you do not have to sign the certification.

**2. Interest, dividend, broker, and barter exchange accounts opened after 1983 and broker accounts considered inactive during 1983.** You must sign the certification or backup withholding will apply. If you are subject to backup withholding and you are merely providing your correct TIN to the requester, you must cross out item 2 in the certification before signing the form.

**3. Real estate transactions.** You must sign the certification. You may cross out item 2 of the certification.

**4. Other payments.** You must give your correct TIN, but you do not have to sign the certification unless you have been notified that you have previously given an incorrect TIN. "Other payments" include payments made in the course of the requester's trade or business for rents, royalties, goods (other than bills for merchandise), medical and health care services (including payments to corporations), payments to a nonemployee for services, payments to certain fishing boat crew members and fishermen, and gross proceeds paid to attorneys (including payments to corporations).

**5. Mortgage interest paid by you, acquisition or abandonment of secured property, cancellation of debt, qualified tuition program payments (under section 529), IRA, Coverdell ESA, Archer MSA or HSA contributions or distributions, and pension distributions.** You must give your correct TIN, but you do not have to sign the certification.

## What Name and Number To Give the Requester

For this type of account:	Give name and SSN of:
1. Individual	The individual
2. Two or more individuals (joint account)	The actual owner of the account or, if combined funds, the first individual on the account <sup>1</sup>
3. Custodian account of a minor (Uniform Gift to Minors Act)	The minor <sup>2</sup>
4. a. The usual revocable savings trust (grantor is also trustee)	The grantor-trustee <sup>1</sup>
b. So-called trust account that is not a legal or valid trust under state law	The actual owner <sup>1</sup>
5. Sole proprietorship or single-owner LLC	The owner <sup>3</sup>
For this type of account:	Give name and EIN of:
6. Sole proprietorship or single-owner LLC	The owner <sup>3</sup>
7. A valid trust, estate, or pension trust	Legal entity <sup>4</sup>
8. Corporate or LLC electing corporate status on Form 8832	The corporation
9. Association, club, religious, charitable, educational, or other tax-exempt organization	The organization
10. Partnership or multi-member LLC	The partnership
11. A broker or registered nominee	The broker or nominee
12. Account with the Department of Agriculture in the name of a public entity (such as a state or local government, school district, or prison) that receives agricultural program payments	The public entity

<sup>1</sup>List first and circle the name of the person whose number you furnish. If only one person on a joint account has an SSN, that person's number must be furnished.

<sup>2</sup>Circle the minor's name and furnish the minor's SSN.

<sup>3</sup>You must show your individual name and you may also enter your business or "DBA" name on the second name line. You may use either your SSN or EIN (if you have one). If you are a sole proprietor, IRS encourages you to use your SSN.

<sup>4</sup>List first and circle the name of the legal trust, estate, or pension trust. (Do not furnish the TIN of the personal representative or trustee unless the legal entity itself is not designated in the account title.) Also see *Special rules regarding partnerships* on page 1.

**Note.** If no name is circled when more than one name is listed, the number will be considered to be that of the first name listed.

## Privacy Act Notice

Section 6109 of the Internal Revenue Code requires you to provide your correct TIN to persons who must file information returns with the IRS to report interest, dividends, and certain other income paid to you, mortgage interest you paid, the acquisition or abandonment of secured property, cancellation of debt, or contributions you made to an IRA, or Archer MSA or HSA. The IRS uses the numbers for identification purposes and to help verify the accuracy of your tax return. The IRS may also provide this

---

information to the Department of Justice for civil and criminal litigation, and to cities, states, the District of Columbia, and U.S. possessions to carry out their tax laws. We may also disclose this information to other countries under a tax treaty, to federal and state agencies to enforce federal nontax criminal laws, or to federal law enforcement and intelligence agencies to combat terrorism.

You must provide your TIN whether or not you are required to file a tax return. Payers must generally withhold 28% of taxable interest, dividend, and certain other payments to a payee who does not give a TIN to a payer. Certain penalties may also apply.

**Attachment 2**

STATE OF CALIFORNIA

Department of Housing and Community Development  
COMMUNITY DEVELOPMENT BLOCK GRANT (CDBG) Program

**Item 5F**

67 of 208

**BIDDER'S SECTION 3 PROPOSED NEW HIRES**

Job Category	Total Estimated Positions Needed for the Project	No. of Positions Occupied by Permanent Employees	Number of Positions Not Occupied	No. of Positions to be filled with Section 3 Residents
Officer/Supervisors				
Professionals				
Technical				
Housing Sales/ Rental Management				
Office/Clerical				
Service Workers				
Others				
TRADE:				
Journeyman				
Apprentices				
Trainees				
Others				
TRADE:				
Journeyman				
Apprentices				
Trainees				
Others				

**Section 3 Resident:**

Individual residing in a public housing project or within the non-metropolitan county in which the project is located and whose income does not exceed 80% of the higher of the median income, adjusted for family size, for the county of residence or the non-metropolitan area of the state.

\_\_\_\_\_  
Company

\_\_\_\_\_  
Project Name

\_\_\_\_\_  
Project Number

\_\_\_\_\_  
Person Completing Form

\_\_\_\_\_  
Date

STATE OF CALIFORNIA  
 Department of Housing and Community Development  
 COMMUNITY DEVELOPMENT BLOCK GRANT (CDBG) Program

**BIDDER'S PROPOSED SECTION 3 CONTRACTS/SUBCONTRACTS**

Type of Contract (Business or Profession)	Total No.	Total Approximate Dollar Amount	Estimated No. of Contracts to Section 3 Businesses	Estimated Dollar Amount to Section 3 Businesses

**Section 3 Business Concern:**

- 1. A business that is 51% or more owned by Section residents, or**
- 2. A business whose permanent full time work force at least 30% are Section 3 residents or,**
- 3. A business which contracts a dollar amount of all subcontracts with businesses as defined in numbers 1 and 2 above.**

\_\_\_\_\_  
 Company

\_\_\_\_\_  
 Project Name

\_\_\_\_\_  
 Project Number

\_\_\_\_\_  
 Person Completing Form

\_\_\_\_\_  
 Date

Attachment A

**CERTIFICATION REGARDING DEBARMENT, SUSPENSION,**

***INELIGIBILITY AND VOLUNTARY EXCLUSION LOWER TIER COVERED TRANSACTIONS***

This certification is required by the regulations implementing Executive Order 12549, Debarment and Suspension, 24 CFR Part 85, Section 85.510, Participants' responsibilities. The regulations were published as Part VII of the May 26, 1988 Federal Register (pages 19160-19211).

***(BEFORE COMPLETING THIS CERTIFICATION, READ INSTRUCTIONS BELOW)***

- (1) The prospective lower tier participant certifies, by submission of this proposal, that neither it nor its principles are presently debarred, suspended, proposed for debarment, declared ineligible, or voluntarily excluded from participation in this transaction by any Federal department or agency.
- (2) Where the prospective lower tier participant is unable to certify to any of the statements in this certification, such prospective participant shall attach an explanation to this proposal.

**Grant Number:** Program Income                      **Name of Participant:** \_\_\_\_\_

**Address of Participant:** \_\_\_\_\_

Name and Title of Authorized Representative	Signature	Date
---	-----------	------

- 1. By signing and submitting this proposal, the prospective lower tier participant is providing the certification set out below.
- 2. The certification in this clause is a material representation of fact upon which reliance was placed when this transaction was entered into. If it is later determined that the prospective lower tier participant knowingly rendered an erroneous certification, in addition to other remedies available to the Federal Government, the department or agency with which this transaction originated may pursue available remedies, including suspension and/or debarment.
- 3. The prospective lower tier participant shall provide immediate written notice to the person to whom this proposal is submitted if at any time the prospective lower tier participant learns that its certification was erroneous when submitted or has become erroneous by reason of changed circumstances.
- 4. The terms "covered transaction", "debarred", "suspended", "ineligible", "lower tier covered transaction", "participant", "person", "primary covered transaction", "principal", "proposal", and "voluntarily excluded", as used in this clause, have the meanings set out in the Definitions and Coverage sections of rules implementing Executive Order 12549.
- 5. The prospective lower tier participant agrees by submitting this proposal that, should the proposed covered transaction be entered into, it shall not knowingly enter into any lower tier covered transaction with a person who is debarred, suspended, declared ineligible, or voluntarily excluded from participation in this covered transaction, unless authorized by the department or agency with which this transaction originated.
- 6. The prospective lower tier participant further agrees by submitting this proposal that it will include the clause titled "Certification Regarding Debarment, Suspension, Ineligibility and Voluntary Exclusion -- Lower Tier Covered Transactions", without modification, in all lower tier covered transactions and in all solicitations for lower tier covered transactions.
- 7. A participant in a covered transaction may rely upon a certification of a prospective participant in a lower tier covered transaction that is not debarred, suspended, ineligible, or voluntarily excluded from the covered transaction, unless it knows that the certification is erroneous. A participant may decide the method and frequency by which it determines the eligibility of its principals. Each participant may check the non-procurement List.
- 8. Nothing contained in the foregoing shall be construed to require establishment of a system of records in order to render in good faith the certification required by this clause. The knowledge and information of a participant is not required to exceed that which is normally possessed by a prudent person in the ordinary course of business dealings.
- 9. Except for transactions authorized under paragraph 5 of these instructions, if a participant in a covered transaction knowingly enters into a lower tier covered transaction with a person who is suspended, debarred, ineligible, or voluntarily excluded from participation in this transaction, in addition to other remedies available to the Federal Government, the department or agency with which this transaction originated may pursue available remedies, including suspension and/or debarment.



## **GENERAL PROVISIONS**

### **SECTION 1 DEFINITIONS**

The following terms as used in any agreement of which these General Provisions are a part are defined as follows:

**1-1.01 Agreement:** The Agreement between the City and Contractor concerning the Project, as evidenced by and comprised of the Contract Documents, sometimes referred to as the Project Agreement or the Contract.

**1-1.02 Base:** A layer of specified material of planned thickness placed immediately below the pavement or surfacing.

**1-1.03 Base Material:** The material in excavation or embankments underlying the lowest layer of subbase, base, pavement, surfacing or other specified layer which is to be placed.

**1-1.04 Bid Package:** All of the documents listed as comprising the entire Bid Package as specified in the Instructions to Bidders and representing the full set of documents made available to bidders on the Project.

**1-1.05 Bridge:** Any structure, with a bridge number, which carries a utility facility, or railroad, highway, pedestrian or other traffic, over a water course or over or under or around any obstruction.

**1-1.06 Caltrans:** The Department of Transportation of the State of California, as created by law.

**1-1.07 Change Order:** An Amendment to the Agreement, the Project Plans, Technical Specifications or other Contract Documents made in accordance with Section 3, Control of Work and Material and Changes in Work, of the General Provisions hereof.

**1-1.08 City:** City of Colfax.

**1-1.09 Conduit:** A pipe or tube in which smaller pipes, tubes or electrical conductors are inserted or are to be inserted.

**1-1.10 Contract Documents:** All those documents listed in the Project Agreement as comprising the entire agreement between the City and the Contractor.

**1-1.11 Contractor:** The successful bidder for the Project and party to the Project Agreement with the City as specified in the Project Agreement.

**1-1.12 Culvert:** Any structure, other than a bridge, which provides an opening under a roadway for drainage or other purposes.

**1-1.13 Days:** Unless otherwise specified in the Contract Documents, days mean working days.

- 1-1.14 Designer:** The person or persons so specified on the Technical Specifications and/or Project Plans.
- 1-1.15 Detour:** A temporary route for traffic around a closed portion of a road.
- 1-1.16 Divided Highway:** A highway with separated traveled ways for traffic, generally in opposite directions.
- 1-1.17 Engineer:** The City’s authorized representative for administration and overall management of the Project Agreement and Work. The Engineer is the official point of contact between the City and the Contractor, and is also known as the “City Engineer”.
- 1-1.18 Frontage Road:** A local street or road auxiliary to and located generally on the side of an arterial highway for service to abutting property and adjacent areas and for control of access.
- 1-1.19 Grading Plane:** The surface of the basement material upon which the lowest layer of subbase, base, pavement, surfacing or other specified layer is placed.
- 1-1.20 Highway:** The whole right of way or area which is reserved for and secured for use in constructing the roadway and its appurtenances.
- 1-1.21 Laboratory:** The established laboratory of the Materials and Research Department of the Department of Transportation of the State of California or laboratories authorized by the Engineer to test materials involved in the contract.
- 1-1.22 Manual on Uniform Traffic Control Devices:** the California Manual on Uniform Traffic Control Devices, latest edition, Caltrans.
- 1-1.23 Median:** That portion of a divided highway separating the traveled ways for traffic in opposite directions including inside shoulders.
- 1-1.24 Office of Structure Design:** The Office of Structure Design as part of the California Department of Transportation. When the specifications require working drawings to be submitted to the Offices of Structure Design, the drawings shall be submitted to: Office of Structure Design, Documents Unit, Mail Station 9-4/4I, 1801 30<sup>th</sup> Street, Sacramento, CA 95816, Telephone (916) 227-8252.
- 1-1.25 Pavement:** The uppermost layer of material placed on the traveled way or shoulders. This term is used interchangeably with surfacing.
- 1-1.26 Processing:** Any operation or operations of whatever nature and extent required to produce a specified material.
- 1-1.27 Project:** The **Culver Street Pavement Rehabilitation** Project as described in the Technical Specifications and Project Plans.

- 1-1.28 Project Inspector:** The party or parties charged by the City with inspecting the Work for compliance with the requirements of the Contract Documents and applicable laws and regulations. The Project Inspector acts under the direction of the City and shall coordinate with the City Engineer as directed by the City in accordance with the Contract Documents.
- 1-1.29 Project Plans:** The primarily graphic detailed requirements concerning the Project contained in the Bid Package and any addenda to the Project Plans signed by authorized City representatives and issued prior to bid opening, Equal Product Proposals accepted by the City and signed by authorized City representatives prior to bid opening, and change orders and other amendments to the Project Plans signed by authorized representatives of the City and the Contractor in accordance with the requirements of the Contract Documents.
- 1-1.30 Roadbed:** The roadbed is that area between the intersection of the upper surface of the roadway and the side slopes or curb lines. The roadbed rises in elevation as each increment or layer of subbase, base, surfacing or pavement is placed thereon. Where the medians are so wide as to include areas of undisturbed land, a divided highway is considered as including 2 separate roadbeds.
- 1-1.31 Roadway:** That portion of the highway included between the outside lines of sidewalks, or curbs, slopes, ditches, channels, waterways, and including all the appertaining structures, and other features necessary to proper drainage and protection.
- 1-1.32 Shoulders:** The portion of the roadway contiguous with the traveled way for accommodation of stopped vehicles, for emergency use, and for lateral support of base and surface courses.
- 1-1.33 Special Provisions:** The special provisions set forth conditions or requirements peculiar to the Work and supplementary to the General Provisions.
- 1-1.34 Standard Specifications:** The directions, provisions and requirements contained in the 2015 Caltrans Specifications.
- 1-1.35 Subbase:** A layer of specified material of planned thickness between a base and the basement material.
- 1-1.36 Subcontractor:** A person, firm or corporation that is obligated as a party to a contract with the Contractor to perform part of the Project work. For purposes of these General Provisions Subcontractors include, but are not limited to, those that are obligated as parties to a contract with the Contractor to specially fabricate and install a portion of the Project Work according to the Technical Specifications and/or Project Plans.
- 1-1.37 Subgrade:** That portion of the roadbed on which pavement, surfacing, base, subbase, or a layer of any other material is placed.
- 1-1.38 Substructure:** All that part of the bridge below the bridge seats, tops of piers, haunches of rigid frames, or below the spring lines of arches. Backwalls and parapets of abutments and wingwalls of bridges shall be considered as parts of the substructure.
- 1-1.39 Superstructure:** All that part of the bridge except the bridge substructure.

**1-1.40 Surfacing:** The uppermost layer of material placed on the traveled way, or shoulders. This term is used interchangeably with pavement.

**1-1.41 Technical Specifications:** The detailed Project requirements contained in the Bid Package and any addenda to the Technical Specifications signed by authorized City representatives and issued prior to bid opening, Equal Product Proposals accepted by the City and signed by authorized City representatives prior to bid opening, and change orders and other amendments to the Technical Specifications signed by authorized representatives of the City and the Contractor in accordance with the requirements of the Contract Documents.

**1-1.42 Traffic Lane:** That portion of a traveled way for the movement of a single line of vehicles.

**1-1.43 Traveled Way:** That portion of the roadway for the movement of vehicles, exclusive of the shoulders.

**1-1.44 Work:** The furnishing of all equipment, tools, apparatus, facilities, material, labor and skill necessary to perform and complete in a good and workmanlike manner the Project as shown in the Technical Specifications and Project Plans in accordance with the Contract Documents and applicable law.

**1-1.45 Written Notice:** Will be deemed to have been duly served for purposes of these General Provisions and any agreement of which they are a part if delivered in person to the individual or to a member of the firm or to any office of the corporation for whom the notice is intended, or if sent by registered or certified mail to the last known business address known to the party giving notice. Unless otherwise specified in the Contract Documents, the last known address of the Contractor shall be that listed in the Contractor's completed Proposal and Schedule of Bid Prices.

## SECTION 2 SCOPE OF WORK

**2-1.01 Documents Furnished by City.** The City will furnish to the Contractor, free of charge five (5) sets of prints of the Project Plans and Technical Specifications for execution of the Work. Throughout the performance of the Work the Contractor must keep one copy of the Project Plans and Technical Specifications in good order and available for review by the Engineer, the Designer, and any other City contractors or representatives.

**2-1.02 Ownership of Documents Furnished by City.** All documents furnished by the City, including, but not limited to, the Technical Specifications, Project Plans, and any copies, are the property of the City. Documents furnished by the City may not to be used on any other work. All documents furnished by the City must be returned to City upon completion of the Work.

### **2-1.03 Technical Specifications and Project Plans.**

- a. The Technical Specifications and Project Plans are complementary and intended to mutually describe the Work necessary to complete the Project in accordance with the Contract Documents.
- b. In general, the Project Plans indicate dimensions, position and kind of construction, and the Technical Specifications indicate qualities and methods. Any Work indicated on the Project Plans and not mentioned in the Technical Specifications or vice versa must be furnished as though fully set forth in both. Work that is not particularly detailed, marked or specified shall be the same as similar Work that is detailed, marked or specified. The Contractor must furnish items necessary for the operation of equipment depicted in the Project Plans or specified in the Technical Specifications that are suitable to allow such equipment to function properly at no extra charge.
- c. The Contractor must notify the Engineer as soon as possible of any apparent errors or inconsistencies, including, but not limited to, typographical or notational errors in the Project Plans, Technical Specifications, and/or in work done by others affecting the Work. The Engineer will issue instructions concerning any such apparent errors or inconsistencies. If the Contractor proceeds with Work impacted by apparent errors or inconsistencies without instructions from the Engineer, the Contractor shall do so at its sole risk and shall have all of the obligations and the City shall have all of the rights and remedies specified in Section 9 concerning any resulting damage or defect.
- d. The General Provisions apply with equal force to all of the Work, including extra work authorized by the Engineer in accordance with the Contract Documents. The Contractor must submit any required shop diagrams and/or drawings by the times and in the quantities indicated in the Technical Specifications. Any such shop diagrams and/or drawings must show completely the Work to be done, expanding on the Project Plans concerning details not previously shown, field conditions and the condition of the Work. Engineer review of such shop diagrams and/or drawings will concern conformance with the requirements of the Contract Documents only. The Engineer assumes no responsibility for the correctness or

accuracy of the dimensions or any other contents of any shop diagrams and/or drawings submitted by the Contractor. The Contractor must check all dimensions at the Work site. Shop diagrams and/or drawings must be clearly marked with the name of the Project and the name of the Contractor, subcontractor or supplier making the submittal, and must be stamped and signed by the Contractor and submitted under a signed transmittal letter from the Contractor certifying that all dimensions have been checked at the Work site. These requirements are mandatory. The Engineer will not review shop diagrams and/or drawings that do not satisfy these requirements. The Contractor will be responsible for any and all discrepancies between dimensions of the actual Project site and/or Work and those shown on shop diagram and/or drawings submitted by the Contractor, and for any other errors contained in or resulting from such shop diagrams and/or drawings, including, but not limited to, errors in material and/or equipment quantities and any resulting errors, delays or additional cost in the performance of the Work. The Contractor will have all of the obligations and the City will have all of the rights and remedies that are specified in Section 9, Remedies and Disputes, concerning any discrepancies or errors in shop diagrams and/or drawings submitted by the Contractor, and concerning any resulting errors, delays or additional costs in the performance of the Work.

**2-1.04 Pre-Construction Conference.** Prior to the issuance of the Notice to Proceed, a pre-construction conference will be held at the City Offices for the purpose of discussing with the Contractor the scope of work, Contract drawings, specifications, existing conditions, materials to be ordered, equipment to be used, and all essential matters pertaining to the prosecution of and the satisfactory completion of the project as required. The Contractor's representative at this conference shall include all major superintendents for the work and may include major subcontractors.

**SECTION 3  
CONTROL OF WORK AND MATERIAL  
AND  
CHANGES IN THE WORK**

**3-1.01 Engineer's Status.** The Engineer will administer the Project in accordance with the Contract Documents. After execution of the agreement and issuance of the Notice to Proceed, all correspondence and/or instructions concerning the Project between the Contractor and/or City shall be forwarded through the Engineer. Except as otherwise provided in the Contract Documents, the Engineer will not be responsible for and will not have control or charge of construction means, methods, techniques, or procedures or for safety precautions in connection with the Work. The Engineer, however, will have authority to reject materials and/or workmanship that do not conform to the requirements of the Contract Documents. The Engineer will also have the authority to require inspection or testing of the Work.

**3-1.02 Designer's Status.** The Designer will advise the Engineer concerning decisions on all claims of the Contractor and all other matters relating to the execution and progress of the Work or the interpretation of the Contract Documents. The Designer will also advise the Engineer concerning Work that does not conform to the Contract Documents. Whenever, in the Designer's opinion, it is necessary or advisable in accordance with the Contract Documents, the Designer may recommend to the Engineer inspection or testing of the Work, whether or not such Work is then fabricated, installed or completed.

**3-1.03 Inspection and Testing of Work and Material.**

- a. The City, the Engineer, the Designer and their representatives will have access to the Work at all times wherever it is in preparation or progress. The Contractor must provide proper facilities for such access and for inspection. The Contractor shall furnish the Engineer a list of the Contractor's sources of materials and the locations at which those materials will be available for inspection. The list shall be furnished to the Engineer in sufficient time to permit inspecting and testing of materials to be furnished from the listed sources in advance of their use. Within three (3) business days of receipt of the list, the Engineer may inspect, sample or test materials at the source of supply or other locations, but the inspection, sampling or testing will not be undertaken until the Engineer is assured by the Contractor of the cooperation and assistance of both the Contractor and the supplier of the material. The Contractor shall assure that the Engineer or the Engineer's authorized representative has free access at all times to the material to be inspected, sampled or tested. Adequate facilities shall be furnished free of charge to the Engineer to make the necessary inspection. The City assumes no obligation to inspect materials at the source of supply. It is understood that the inspections and tests if made at any point other than the point of incorporation in the Work in no way shall be considered as a guaranty of acceptance of the material nor of continued acceptance of material presumed to be similar to that upon which inspections and tests have been made, and that inspection and testing performed by the City shall not relieve the Contractor or the Contractor's suppliers of responsibility for quality control.

- b. The Contractor must inspect all materials as delivered and promptly return all defective materials without waiting for their rejection by the Designer or Engineer. The Contractor shall be responsible for controlling the quality of the material entering the Work and of the Work performed, and shall perform testing as necessary to ensure control. The test methods used for quality control testing shall be as determined by the Contractor and this Agreement. The results of the testing shall be made available to the Engineer upon request. These tests are for the Contractor's use in controlling the Work and will not be accepted for use as acceptance tests. Full compensation for performing quality control tests and making the results available to the Engineer shall be considered as included in the Contract Prices and no additional compensation will be allowed therefor.
- c. If the Engineer, the Technical Specifications, or any laws, ordinances, or any public authority require any Work to be tested or approved, the Contractor must give the Engineer timely notice of the Contractor's readiness for inspection. Inspections will be promptly made, and where practicable, at the source of supply. Any work subject to such testing that is covered up without timely notice to the Engineer or without the approval or consent of the Engineer must, if required by the Engineer, be uncovered for examination at the Contractor's expense. The Contractor will have all of the obligations and the City will have all of the rights and remedies that are specified in Section 9 of these General Provisions concerning any work subject to testing that is covered up without timely notice to the Engineer and that is not uncovered for examination at the Contractor's expense if required by the Engineer.
- d. Tests of materials or qualification tests required by the Contract Documents must be made in accordance with the Technical Specifications and the requirements of the California Building Standards Code, where applicable, as adopted by the City, and other applicable law. Copies of all testing reports shall be distributed as required in the Technical Specifications. The laboratory or inspection agency shall be selected by the City. The City will pay for all laboratory inspection service direct, and not as a part of the Contract. Materials of construction, particularly those upon which the strength and durability of the structure may depend, shall be subject to inspection and testing to establish conformance with specifications and suitability for uses intended.
- e. The City or its representatives may order re-examination of questioned Work. If ordered to do so, the Contractor must uncover such Work. If such Work is found to be according to the Contract Documents, the City shall pay the cost of uncovering and restoring the Work, unless such Work was subject to testing and covered up without timely notice to or approval of the Engineer. If re-examined Work is found not in accordance with the Contract Documents, the Contractor must pay the cost of uncovering and restoring the Work. The Contractor will have all of the obligations and the City will have all of the rights and remedies that are specified in Section 9 of these General Provisions concerning any re-examined Work not in accordance with the Contract Documents that the Contractor fails to uncover and restore at the Contractor's expense.
- f. The Contractor must replace or correct without charge any material or workmanship found not to conform to the requirements of the Contract Documents, unless the City consents to accept such material or workmanship with an appropriate adjustment in the Contract Price. The Contractor must promptly segregate and remove non-conforming material from the



Work site. The Contractor will have all of the obligations and the City will have all of the rights and remedies that are specified in Section 9 of these General Provisions concerning any failure by the Contractor to replace or correct without charge any material or workmanship that does not conform to the requirements of the Contract Documents and that the City has not consented to accept.

- g. Any work done beyond the lines and grades shown on the Project Plans or established by the Engineer, or any extra work done without written authority will be considered as unauthorized work and will not be paid for. Upon order of the Engineer unauthorized work shall be remedied, removed or replaced at the Contractor's expense.
- h. The inspection of the Work or materials shall not relieve the Contractor of any of the Contractor's obligations to fulfill the Agreement. Work and materials not meeting Agreement requirements shall be made good, and unsuitable Work or materials may be rejected, notwithstanding that the Work or materials have been previously inspected by the Engineer or that payment therefore has been given.
- i. Unless otherwise specified, all tests shall be performed in accordance with the methods used by Caltrans and shall be made by the Engineer or the Engineer's designated representative.
- j. The City has developed methods for testing the quality of materials and work. These methods are identified by number and are referred to in the Technical Specifications as California Tests. Copies of individual California Tests are available at the Transportation Laboratory, Sacramento, California, and will be furnished to interested persons upon request.
- k. Whenever the specifications require compliance with specified values for the following properties, tests will be made by the California Test indicated unless otherwise specified:

Properties	California Test
Relative Compaction	216 or 231
Sand Equivalent	217
Resistance (R-value)	301
Grading (Sieve Analysis)	202
Durability Index	229

- l. Whenever a reference is made in the Technical Specifications to a California Test by number, it shall mean the California Test in effect on the day the Agreement is signed on behalf of the City.
- m. Whenever the Technical Specifications provide an option between 2 or more tests, the Engineer will determine the test to be used.
- n. Whenever a reference is made in the Technical Specifications to a specification, manual or test designation either of the American Society for Testing and Materials, the American Association of State Highway and Transportation Officials, Federal Specifications or any other recognized national organization, and the number or other identification representing the year of adoption or latest revision is omitted, it shall mean the specification, manual or

test designation in effect on the day the Agreement is signed on behalf of the City. Whenever the specification, manual or test designation provides for test reports (such as certified mill test reports) from the manufacturer, copies of those reports, identified as to the lot of material, shall be furnished to the Engineer. The manufacturer's test reports shall supplement the inspection, sampling and testing provisions in this Section, and shall not constitute a waiver of the City's right to inspect. When material which cannot be identified with specific test reports is proposed for use, the Engineer may, at the Engineer's discretion, select random samples from the lot for testing. Test specimens from the random samples, including those required for retest, shall be prepared in accordance with the referenced specification and furnished by the Contractor at the Contractor's expense. The number of the samples and test specimens shall be entirely at the discretion of the Engineer. Unidentified metal products, such as sheet, plate and hardware shall be subject to the requirements of Section 55-1.02A(6), "Unidentified Stock Material" of the Standard Specifications.

- o. When requested by the Engineer, the Contractor shall furnish, without charge, samples of all materials entering into the Work, and no material shall be used prior to approval by the Engineer, except as provided in Section 3-1.04, "Certificates of Compliance." Samples of material from local sources shall be taken by or in the presence of the Engineer; otherwise, such samples will not be considered for testing.

**3-1.04 Certificates of Compliance.**

- a. Certificates of Compliance shall be furnished prior to the use of any materials for which the Technical Specifications require that a certificate be furnished. In addition, when so authorized in the Technical Specifications, the Engineer may permit the use of certain materials or assemblies prior to sampling and testing if accompanied by a Certificate of Compliance. The certificate shall be signed by the manufacturer of the material or the manufacturer of assembled materials and shall state that the materials involved comply in all respects with the requirements of the Technical Specifications. A Certificate of Compliance shall be furnished with each lot of material delivered to the work and the lot so certified shall be clearly identified in the certificate.
- b. Materials used on the basis of a Certificate of Compliance may be sampled and tested at any time. The fact that material is used on the basis of a Certificate of Compliance shall not relieve the Contractor of responsibility for incorporating material in the Work which conforms to the requirements of the Project Plans and Technical Specifications, and any material not conforming to the requirements will be subject to rejection whether in place or not.
- c. The City reserves the right to refuse to permit the use of material on the basis of a Certificate of Compliance.
- d. The form of the Certificate of Compliance and its disposition shall be as directed by the Engineer.

**3-1.05 Samples Furnished by the Contractor.** The Contractor must furnish all samples for approval as directed in sufficient time to permit the Designer or Engineer to examine, approve and select samples before they are required by the progress of the Work. Portions of the Work for which samples are required and for which the Designer or Engineer has selected samples must be in accordance with such approved samples. Samples must be sent prepaid to the office of the Engineer or to such place as the Engineer may direct.

**3-1.06 Materials and Substitutions.**

- a. Materials used for the Work must be new and of the quality specified. When not particularly specified, materials must be the best of their class or kind. The Contractor must, if required, submit satisfactory evidence as to the kind and quality of materials.
- b. If the Contractor submitted complete information to the Public Works Department for products proposed as equals in accordance with the bid package, and the City approved such products proposed as equals in writing, the Contractor may either furnish such products approved as equals, or furnish the products listed by manufacturer name, brand or model number in the Technical Specifications or Project Plans. The City retains the right, in its sole discretion, to accept or reject any other proposed substitution. To be considered, proposals concerning products proposed as equals must include sufficient information to permit the City to determine whether the products proposed as equals will satisfy the same performance requirements as products listed by manufacturer's name, brand or model number. Such performance requirements may include, but are not limited to, size, strength, function, appearance, ease of maintenance and repair, and useful life requirements. If the City does not accept a proposed substitution, the Contractor must furnish the product specified in the Technical Specifications or Project Plans for the Contract Price, regardless of whether the product is specified by manufacturer's name, brand or model number, or otherwise.

**3-1.07 Contractors Responsibility For The Work And Materials.**

- a. Until the acceptance of the Work, the Contractor shall have the charge and care of the Work and of the materials to be used and shall bear the risk of injury, loss or damage to any part thereof by the action of the elements or from any other cause, whether arising from the execution or from the non-execution of the Work, except as provided in Sections 6-1.16, "Public Convenience," and 5-1.11, "Relief From Maintenance and Responsibility." The Contractor shall rebuild, repair, restore, and make good all injuries, losses or damages to any portion of the Work or the materials occasioned by any cause before its completion and acceptance and shall bear the expense thereof, except for those injuries, losses, or damages that are directly and proximately caused by acts of the Federal Government or the public enemy. Where necessary to protect the Work or materials from damage, the Contractor shall, at the Contractor's expense, provide suitable drainage of the roadway and erect those temporary structures that are necessary to protect the Work or materials from damage. The suspension of the Work from any cause whatever shall not relieve the Contractor of the responsibility for the Work and materials as herein specified. If ordered by the Engineer, the Contractor shall, at the Contractor's expense, properly store materials which have been partially paid for by the City or which have been furnished by the City. Storage by the

Contractor shall be on behalf of the City and the City shall at all times be entitled to the possession of the materials, and the Contractor shall promptly return the materials to the site of the Work when requested. The Contractor shall not dispose of any of the materials so stored except on written authorization from the Engineer.

- b. During the performance of the Work, all materials must be neatly stacked, properly protected from the weather and other adverse impacts, and placed so as to avoid interference with efficient progress of the Work, with other activities of the City, or with the use of existing City facilities by the public. All materials must be delivered so as to ensure efficient and uninterrupted progress of the Work. Materials must be stored so as to cause no obstruction and so as to prevent overloading of any portion of the Work. The Contractor will be responsible for damage or loss of materials delivered to and/or stored at the Work site due to weather or other causes. The Contractor must promptly remove from the Work site all materials rejected by the City or its representatives as failing to conform to the requirements of the Contract Documents, whether such non-conforming materials have been incorporated in the Work or not. If the City or its representatives so direct, the Contractor must promptly replace and re-execute Work performed by the Contractor and order the replacement and re-execution of Work performed by subcontractors using non-conforming materials with materials that satisfy the requirements of the Contract Documents without expense to the City. The Contractor will bear the expense of making good all Work destroyed or damaged by such removal. The Contractor will have all of the obligations and the City will have all of the rights and remedies that are specified in Section 9 of these General Provisions concerning any failure by the Contractor to replace or re-execute Work using non-conforming materials, and/or to make good all work destroyed or damaged by such removal and/or execution.

**3-1.08 Audit and Examination of Records.** The City may examine and audit at no additional cost to the City all books, estimates, records, contracts, documents, bid documents, bid cost data, subcontract job cost reports and other Project related data of the Contractor, subcontractors engaged in performance of the Work, and suppliers providing supplies, equipment and other materials required for the Work, including computations and projections related to bidding, negotiating, pricing or performing the Work or contract modifications and other materials concerning the Work, including, but not limited to, Contractor daily logs, in order to evaluate the accuracy, completeness, and currency of cost, pricing, scheduling and any other project related data. The Contractor will make available all such Project related data at all reasonable times for examination, audit, or reproduction at the Contractor's business office at or near the Work site, and at any other location where such Project related data may be kept until three years after final payment under the Agreement. Pursuant to California Government Code Section 8546.7, if the amount of public funds to be expended is in excess of \$10,000, this Agreement shall be subject to the examination and audit of the State Auditor, at the request of the City, or as part of any audit of the City, for a period of three (3) years after final payment under the Agreement.

**3-1.09 Advertising.** No advertising signs of any kind may be displayed on the Work site, or on fences, offices or elsewhere adjacent to the Work site.

**3-1.10 Project Schedule.** Within seven (7) days of issuance of the Notice to Proceed, the Contractor must submit a schedule showing each task of Work, the sequence of each task, the number of

days required to complete each task, and the critical path controlling the completion of the entire Work. The schedule must allow for the completion of the entire Work within the Time for Completion.

- a. City Review of Schedule. The City may review the Contractor's submitted schedule and may note any exceptions. The Contractor must correct any exceptions noted by the City within five (5) working days of being notified of the exceptions.
- b. Update of Schedule. After submission of a schedule to which the City has taken no exceptions, the Contractor must submit an updated schedule on a biweekly basis or as otherwise specified by the City until completion of the Work. The updated schedule must show the progress of Work as of the date specified in the updated schedule.
- c. Float. The schedule shall show early and late completion dates for each task. The number of days between these dates will be designated as "float". The Float will be designated to the Project and will be available to both the City and the Contractor as needed.
- d. Failure to Submit Schedule. If the Contractor fails to submit schedules within the time periods specified in this Section, or submit a schedule to which the City has taken uncorrected exceptions, the City may withhold payments to the Contractor until such schedules are submitted and/or corrected in accordance with the Contract Documents.
- e. Responsibility for Schedule. The Contractor will be solely and exclusively responsible for creating the schedule and properly updating it. The City may note exceptions to any schedule submitted by the Contractor. However, the Contractor will be solely responsible for determining the proper method for addressing such exceptions and the City's review of the schedule will not place scheduling obligation on the City.

**3-1.11 Construction Staking.** Where the Contract Documents require, the Contractor shall employ a licensed Land Surveyor to perform construction staking. Stakes and marks will be set by the Surveyor as the Engineer determines to be necessary to establish the lines and grades required for the completion of the Work.

- a. The Contractor will be responsible for coordinating performance of the Work with the Surveyor and for all costs associated with construction staking and layout.
- b. Contractor shall provide "cutsheets" for the Engineer to review and use in checking grades. Finished grades shall be within 0.01 feet in elevation and 0.03 feet horizontal layout of the grades as shown on the plans.
- c. Full compensation for Construction Staking shall be considered as included in the prices paid for the various items of Work involved, and no additional payment will be made therefore by the City.

**3-1.12 Detours.**

- a. The Contractor shall construct and remove detours and detour bridges for the use of public traffic as provided in the Special Provisions, or as shown on the Project plans or as directed by the Engineer. Payment for this Work will be made as set forth in the Special Provisions or at the contract prices for the items of Work involved
- b. The cost of repairing damage to detours caused by public traffic will be paid for as provided in this Section 3 of these General Provisions.
- c. When public traffic is routed through the Work, provision for a passageway through construction operations will not be considered as detour construction or detour maintenance, and this Work shall conform to and be paid for as provided in Section 6-1.16, "Public Convenience" of these General Provisions unless otherwise specified in the Special Provisions.
- d. Detours used exclusively by the Contractor for hauling materials and equipment shall be constructed and maintained by the Contractor at the Contractor's expense.
- e. The failure or refusal of the Contractor to construct and maintain detours at the proper time shall be sufficient cause for suspending the Work until the detours are in satisfactory condition for use by public traffic.
- f. Where the Contractor's hauling is causing such damage to the detour that its maintenance in a condition satisfactory for public traffic is made difficult and unusually expensive, the Engineer shall have authority to regulate the Contractor's hauling over the detour.

**3-1.13 City Directed Change Orders.** The City may at any time during the progress of the Work direct the Contractor by Change Orders, being any amendments to the Work or any of the Contract Documents, including, but not limited to the Technical Specifications, or Project Plans. Such amendments will in no way void the Agreement, but will be applied to amend the Contract Price, if such amendments affect the Contract Price or the Project schedule, or if such amendments affect the Project schedule, or any other provision of the Contract Documents based on a fair and reasonable valuation of the Change Order in accordance with this Section 3 of these General Provisions.

**3-1.14 Writing Requirement.** Change Orders and other related amendments to the Technical Specifications, the Project Plans, or other Contract Documents may be made only by a writing executed by authorized representatives of the City and the Contractor.

**3-1.15 Contractor Proposed Change Orders.** Unless the Engineer otherwise authorizes or the City and the Contractor otherwise agree, Change Order proposals submitted by the Contractor must be submitted to the Engineer no later than the time of the proposed change. The Project Manager shall review the proposed Change Order and respond by acknowledging the contract change, or by supplying information and not acknowledging a Change Order, or by recommending other action. If the Project Manager acknowledges the contract change, the Contractor shall submit a Change Order to the Project Manager as set forth in this Section 3-1.15. Each Change Order submitted by the Contractor shall be accompanied by the following certification executed by an officer of Contractor:

I, \_\_\_\_\_, being the \_\_\_\_\_ of \_\_\_\_\_ (Contractor), declare under penalty of perjury under the laws of the State of California, and do personally certify and attest that: I have thoroughly reviewed the attached request for Change Order and know its contents, and said request for Change Order is made in good faith; that it is supported by truthful and accurate data; that the amount requested and the additional time requested accurately reflects the allowable expenses that would be incurred, and the time necessary, to perform the Change Order; and further, that I am familiar with California Penal Code section 72 and California Government Code Section 12650, et seq., pertaining to false claims, and further know and understand that submission or certification of a false claim may lead to fines, imprisonment, or other severe legal consequences.

**3-1.16 All Change Orders.** All proposed Change Orders must be submitted on completed Change Order forms provided in the Contract Documents. All such proposed Change Orders must itemize all cost impacts of the proposed Change Order and include a total price for that change order and the amended Contract Price that would become effective upon execution of the Change Order. All proposed Change Orders must specify any change in the Project schedule, or in any project milestone including, but not limited to, the Time for Completion, under the Change Order. It is understood that Change Orders that do not specify a change in any milestone, including, but not limited to, the Time for Completion, must be accomplished by the Time for Completion then in effect.

**3-1.17 Change Order Pricing.** Change Order pricing for all Change Orders, whether, additive, deductive, or both, will be governed by the following:

- a. Prices specified in the Contract Documents will apply to cost impacts involving items for which the Contract Documents specify prices.
- b. Cost impacts involving items for which the Contract Documents do not specify prices may be paid on a lump sum basis as approved by the City.
- c. For cost impacts involving items for which the Contract Documents do not specify prices, and for which no lump sum amount has been approved by the City, charges or credits for the Work will be paid on a time and materials basis in accordance with the following and subject to Caltrans Standard Specifications, Section 9-1.04, concerning allowable direct charges. The time and materials payment will be the sum of and limited to the direct and indirect costs for labor, materials, equipment and overhead calculated as follows:
  1. Labor: The Contractor will be paid the cost of labor for the workers (including foremen when authorized by the Engineer), used in the actual and direct performance of the Work. The cost of labor utilized in performing the Work, whether the employer is the Contractor, a subcontractor or other entity engaged in the performance of the Work, will be the sum of the following:
    - Actual Wages: The actual wages paid will include any employer fringe benefit payments to or on behalf of the workers for health and welfare, pension, vacation and similar purposes. The actual wages and fringe benefits paid must

be at the rates shown on the certified payroll documents submitted by the Contractor.

- Labor Surcharge: The labor surcharge will be as set forth in the latest edition of the California Department of Transportation publication entitled “Labor Surcharge and Equipment Rental Rates”. The labor surcharge will constitute full compensation for all payments imposed by State or Federal laws and for all other payments made to, or on behalf of, workers engaged in the performance of the Work, excluding the Actual Wages as defined above.
  - Fixed Markup: A fixed markup of 15% of the sum of the actual wages paid and the labor surcharge applicable to such actual wages, together with the actual wage and labor surcharge costs described in this provision will constitute full and complete compensation for all overhead, profit, incidentals, and any and all other direct or indirect expenses associated with furnishing all labor for the Work.
2. Materials: Materials costs will be the direct costs for materials actually exhausted, consumed or entering permanently into the Work, plus a fixed markup of 15% of such direct materials costs, which, together with the direct cost of materials as described in this provision will constitute full and complete compensation for all overhead, profit, incidentals, and any and all other direct or indirect expenses associated with furnishing all materials for the Work.
  3. Equipment: All equipment used will be paid in accordance with the rates in Section 9-1.04D entitled “Equipment Rental” of the Standard Specifications, which is made a part of this Contract, plus a fixed markup of 10% of such equipment rates, which, together with the equipment rates as described in this provision will constitute full and complete compensation for all overhead, profit, incidentals, and any and all other direct or indirect expenses associated with furnishing all equipment for the Work.
  4. Unless approved in writing in accordance with Section 3-1.14 of these General Provisions in advance of performance of the Work, any and all other cost impacts (including, but not limited to profit, bond premiums or fees, insurance premiums or fees, superintendent labor, clerical expenses, home office expenses, Work site office expenses, utility costs, permit costs, and licensing costs) involving items for which the Contract Documents do not specify prices, and for which no lump sum amount has been approved by the City, will constitute incidentals, full compensation for which will be deemed included in the markups for labor, material, and equipment specified above, and no additional compensation for such cost impacts will be allowed.

**3-1.18 Liability Under Unapproved Change Orders.** The Contractor will be solely responsible for any and all losses, costs, or liabilities of any kind incurred by the Contractor, any subcontractor engaged in the performance of the Work, any party supplying material or equipment for the Work or any third party that are incurred pursuant to Contractor-proposed Change Orders prior to issuance of an approved Change Order executed in accordance with this Section 3 of these General Provisions. The Contractor will have all of the obligations and the City will have all of



the rights and remedies that are specified in Section 9 of these General Provisions concerning any work or resulting losses, costs, or liabilities pursuant to a Contractor proposed Change Order before issuance of an approved Change Order executed in accordance with this Section 3 of these General Provisions.

**3-1.19 Changes Subject to Contract Documents.** Any changes in the Work and/or the Contract Documents pursuant to Change Orders and any other amendments issued in accordance with the Contract Documents, including this Section 3 of these General Provisions, will in all respects be subject to all provisions of the Contract Documents, including, but not limited to, the Technical Specifications and the Project Plans, except as modified by such Change Orders or amendments.

**3-1.20 Change Order Disputes.**

- a. Disputed City Directed Change Orders. If the Contractor disputes a City- Directed Change Order following a reasonable effort by the City and the Contractor to resolve the dispute including, at a minimum, a meeting between appropriate representatives of the Contractor and the City, the Contractor must commence performing the Work consistent with the disputed Change Order within five (5) working days of the last meeting between representatives of the Contractor and the City to resolve the dispute, or within the time specified in the disputed City-Directed Change Order, whichever is later. In performing Work consistent with a disputed City-Directed Change Order pursuant to this Section 3-1.20 the Contractor will have all of the Contractor’s rights concerning claims pursuant to the Contract Documents and applicable law.
- b. Disputed Contractor Proposed Change Orders. If the City disputes a Contractor-Proposed Change Order, the City and the Contractor will use reasonable efforts to resolve the dispute including, at a minimum, holding a meeting between appropriate representatives of the Contractor and the City. Regardless of and throughout any such efforts to resolve the dispute the Contractor must continue performing the Work irrespective of and unmodified by the disputed Change Order. In continuing to perform the Work, the Contractor will retain all of the Contractor’s rights under contract or law pertaining to resolution of disputes and protests between contracting parties. Disputes between the City and the Contractor concerning any Contractor-Proposed Change Order or other amendment do not excuse the Contractor’s obligation to perform the Work in accordance with the Contract Documents excluding such Contractor-Proposed Change Order or other amendment by the Time for Completion or waive any other Project milestone or other requirement of the Contract Documents.

**SECTION 4  
TRENCHING AND UTILITIES  
AND  
PROJECT FACILITIES**

**4-1.01** The Construction Safety Orders of the Division of Occupational Safety and Health shall apply to all excavations.

- a. Detailed plans of protective systems for which the Construction Safety Orders require design by a registered professional engineer shall be prepared and signed by an engineer who is registered as a Civil Engineer in the State of California, and shall include the soil classification, soil properties, soil design calculations that demonstrate adequate stability of the protective system, and any other design calculations used in the preparation of the plan.
- b. No plan shall allow the use of a protective system less effective than that required by the Construction Safety Orders.
- c. If the detailed plan includes designs of protective systems developed only from the allowable configurations and slopes, or Appendices, contained in the Construction Safety Orders, the plan shall be submitted at least 5 days before the Contractor intends to begin excavation. If the detailed plan includes designs of protective systems developed from tabulated data, or designs for which design by a registered professional engineer is required, the plan shall be submitted at least 3 weeks before the Contractor intends to begin excavation.

**4-1.02 Excavation More Than Four Feet Deep.** In accordance with California Public Contract Code Section 7104, if the Work involves excavation more than four feet deep the Contractor must promptly notify the City in writing before disturbing: (1) any material that the Contractor believes may be hazardous waste, as defined in Section 25117 of the Health and Safety Code, that is required to be removed to a Class I, Class II or Class III disposal site in accordance with provisions of existing law; any subsurface or latent physical conditions at the Work site differing from those indicated; or, (2) any unknown physical conditions at the Work site of any unusual nature, different materially from those ordinarily encountered and generally recognized as inherent in work of the character provided for in the Contract Documents. The City will promptly investigate any such conditions for which notice is given. If the City finds that the conditions do materially differ, or involve hazardous waste, and would cause a decrease or increase in the cost or time of performance of the Work, the City will issue a Change Order pursuant to Section 3 of these General Provisions. If a dispute arises between the City and the Contractor concerning whether the conditions materially differ, or involve hazardous waste, or cause a decrease of increase in the cost or time of performance, the Contractor will not be excused from any completion date provided in the Contract Documents, but shall proceed with all Work to be performed. The Contractor will retain all rights under contract or law pertaining to resolution of disputes and protests between contracting parties.

**4-1.03 Excavation of Five Feet or More.** In accordance with California Labor Code Section 6705, contractors performing contracts exceeding \$25,000 in cost and involving excavation five or

more feet deep must submit for the City's acceptance, prior to excavation, a detailed plan showing the design of shoring, bracing, sloping, or other provisions to be made for worker protection from the hazard of caving ground during excavation. The detailed plan shall include any tabulated data and any design calculations used in the preparation of the plan. Excavation shall not begin until the detailed plan has been reviewed and approved. If the plan varies from the shoring system standards, it must be prepared by a registered civil or structural engineer.

**4-1.04 Utility Relocation Costs.**

- a. In accordance with California Government Code Section 4215, the City assumes the responsibility for the timely removal, relocation or protection of existing main or trunkline utility facilities located on the Work site if such utilities are not identified by the City in the Technical Specifications and/or Project Plans. The City will compensate the Contractor for the costs of locating, repairing damage not due to the Contractor's failure to exercise reasonable care, and removing or relocating existing main or trunkline utility facilities located at the Work site and not identified with reasonable accuracy in the Technical Specifications and/or Project Plans. The City will also compensate the Contractor for the cost of equipment on the Project necessarily idled during such work. The Contractor will not be assessed liquidated damages for Work completion delays caused by the City's failure to provide for removal or relocation of such main or trunkline utility facilities.
- b. Nothing in this Section 4-1.04 or the Contract Documents will be deemed to require the City to indicate the presence of existing service laterals or appurtenances whenever the presence of such utilities on the Work site can be inferred from the presence of other visible facilities, such as buildings, meter and junction boxes, on or adjacent to the Work site; provided, however, that nothing in this provision or the Contract Documents shall relieve the City from identifying main or trunklines in the Technical Specifications and/or Project Plans.
- c. Nothing in this Section 4-1.04 or the Contract Documents will preclude the City from pursuing any appropriate remedy against the utility for delays which are the responsibility of the utility.
- d. Nothing in this Section 4-1.04 or the Contract Documents will be construed to relieve the utility from any obligation as required either by law or by contract to pay the cost of removal or relocation of existing utility facilities.
- e. If the Contractor while performing the Work discovers utility facilities not identified by the City in the Technical Specifications and/or Project Plans, the Contractor must immediately notify the City and utility in writing.
- f. Either the City or the utility, whichever owns existing main or trunkline utility facilities located on the Work site, shall have sole discretion to effect repairs or relocation work or to permit the Contractor to perform such repairs or relocation work at a reasonable price.

**4-1.05 Utility and Non-Highway Facilities**

- a. The Contractor shall protect from damage utility and other non-highway facilities that are to remain in place, be installed, relocated or otherwise rearranged.

- b. It is anticipated that some or all of the utility and other non-highway facilities, both above ground and below ground, that are required to be rearranged (as used herein, rearrangement includes installation, relocation, alteration or removal) as a part of the highway improvements comprising part of the Work will be rearranged in advance of construction operations. Where it is not anticipated that the rearrangement will be performed prior to construction, or where the rearrangement must be coordinated with the Contractor's construction operations, the existing facilities that are to be rearranged will be indicated on the Project Plans or in the Special Provisions. Where a rearrangement is indicated on the Project Plans or in the Special Provisions, the Contractor will have no liability for the costs of performing the work involved in the rearrangement.
- c. The right is reserved to the City and the owners of facilities, or their authorized agents, to enter upon the highway right of way for the purpose of making those changes that are necessary for the rearrangement of their facilities or for making necessary connections or repairs to their properties. The Contractor shall cooperate with forces engaged in this Work and shall conduct operations in such a manner as to avoid any unnecessary delay or hindrance to the Work being performed by the other forces. Wherever necessary, the work of the Contractor shall be coordinated with the rearrangement of utility or other non-highway facilities, and the Contractor shall make arrangements with the owner of those facilities for the coordination of the Work.
- d. Attention is directed to the possible existence of underground main or trunk line facilities not indicated on the Project Plans or in the Special Provisions and to the possibility that underground main or trunk lines may be in a location different from that which is indicated on the Project Plans or in the Special Provisions. The Contractor shall ascertain the exact location of underground main or trunk lines whose presence is indicated on the Project Plans or in the Special Provisions, the location of their service laterals or other appurtenances, and of existing service lateral or appurtenances of any other underground facilities which can be inferred from the presence of visible facilities such as buildings, meters and junction boxes prior to doing Work that may damage any of the facilities or interfere with their service.
- e. If the Contractor cannot locate an underground facility whose presence is indicated on the Project Plans or in the Special Provisions, the Contractor shall so notify the Engineer in writing. If the facility for which the notice is given is in a substantially different location from that indicated on the Project Plans or in the Special Provisions, the additional cost of locating the facility will be paid for as provided in Section 3.
- f. If the Contractor discovers underground main or trunk lines not indicated on the Project Plans or in the Special Provisions, the Contractor shall immediately give the Engineer and the Utility Company written notification of the existence of those facilities. The main or trunk lines shall be located and protected from damage as directed by the Engineer, and the cost of that work will be paid for as extra work as provided in Section 3. The Contractor shall, if directed by the Engineer, repair any damage which may occur to the main or trunk lines. The cost of that repair work, not due to the failure of the Contractor to exercise reasonable care, will be paid for as provided in Section 3. Damage due to the Contractor's failure to exercise reasonable care shall be repaired at the Contractor's cost and expense.

- g. Where it is determined by the Engineer that the rearrangement of an underground facility is essential in order to accommodate the highway improvement and the Project Plans and Technical Specifications do not provide that the facility is to be rearranged, the Engineer will provide for the rearrangement of the facility by other forces or the rearrangement shall be performed by the Contractor and will be paid for as provided in Section 3.
- h. When ordered by the Engineer in writing, the Contractor shall rearrange any utility or other non-highway facility necessary to be rearranged as a part of highway improvements comprising part of the Work, and that Work will be paid for as provided in Section 3.
- i. Should the Contractor desire to have any rearrangement made in any utility facility, or other improvement, for the Contractor's convenience in order to facilitate the Contractor's construction operations, which rearrangement is in addition to, or different from, the rearrangements indicated on the Project Plans or in the Special Provisions, the Contractor shall make whatever arrangements are necessary with the owners of the utility or other non-highway facility for the rearrangement and bear all expenses in connection therewith.
- j. The Contractor shall immediately notify the Engineer of any delays to the Contractor's operations as a direct result of underground main or trunk line facilities which were not indicated on the Project Plans or in the Special Provisions or were located in a position substantially different from that indicated on the Project Plans or in the Special Provisions, or as a direct result of utility or other non-highway facilities not being rearranged as herein provided (other than delays in connection with rearrangement made to facilitate the Contractor's construction operations or delays due to a strike or labor dispute). Compensation for the delay will be determined in conformance with the provisions in Section 3.

**4-1.06 Work Site Offices.** Any Work site office facilities used by the Contractor and/or its privities must conform to all applicable codes, ordinances and regulations. The cost of such Work site office facilities shall be paid from and included in the Contract Price.

**4-1.07 City Rights of Access and Ownership.** The City and its authorized representatives will at all reasonable times while such office facilities are located at the Work site (including, at a minimum, all times during which the Work is performed), have access to any such Work site office facilities used by the Contractor and/or its privities. With respect to the right of access of the City and its authorized representatives, neither the Contractor nor its privities shall have a reasonable expectation of privacy pursuant to the Fourth Amendment to the Unites States Constitution or other applicable law concerning such Work site office facilities used by the Contractor and/or its privities. Without exception, any and all Project related materials located at such Work site facilities will be deemed at all times to be City property subject to inspection and copying by the City and its authorized representatives at all reasonable times while such facilities are located at the Work site (including, at a minimum, all times during which the Work is performed). Any interference by the Contractor or its privities with the City's rights of access and/or ownership pursuant to this Section 4 will constitute a material breach of the Agreement subject to any and all remedies available pursuant to the Contract Documents and at law and equity.

**SECTION 5  
PROSECUTION AND PROGRESS OF THE WORK**

**5-1.01 Beginning of Work.**

- a. The Contractor shall begin Work within 10 calendar days after receiving notice to proceed from the City, and shall diligently prosecute the same to completion within the Time for completion specified in this Agreement.
- b. Should the Contractor begin Work in advance of receiving notice that this Agreement has been approved as above provided, any Work performed by the Contractor in advance of the date of approval shall be considered as having been done by the Contractor at the Contractor's own risk and as a volunteer unless the Agreement is approved.
- c. The delivery to the City for execution and approval of the Agreement properly executed on behalf of the Contractor and surety and all other required documents in accordance with the Agreement shall constitute the Contractor's authority to enter upon the Work site and to begin operations, subject to the Contractor's assumption of the risk of the disapproval of the Agreement, as above provided, and subject also to the following:
  1. The Contractor shall, on commencing operations, take all precautions required for public safety and shall observe all the provisions in the Contract Documents.
  2. In the event of disapproval, the Contractor shall at the Contractor's expense do that work that is necessary to leave the site in a neat condition to the satisfaction of the Engineer. If the Work done affects any existing road or highway, the Contractor shall at the Contractor's expense restore it to its former condition, or the equivalent thereof, to the satisfaction of the Engineer.
  3. All Work done according to the Agreement prior to its approval, will, when the Agreement is approved, be considered authorized Work and will be paid for as provided in the Agreement.
  4. The Contractor shall not be entitled to any additional compensation or an extension of time for any delay, hindrance or interference caused by or attributable to commencement of Work prior to the date on which the Agreement was approved by the City.

**5-1.02 Liquidated Damages.** Time is of the essence in the performance of this Agreement. The City and the Contractor agree that it will be difficult and/or impossible to determine the actual damage which the City will sustain in the event of the Contractor's failure to fully perform the Work or to fully perform all of the Contractor's obligations that have accrued pursuant to the Agreement by the Time for Completion. Accordingly, the City and the Contractor agree in accordance with California Government Code Section 53069.85 that the Contractor will forfeit and pay to the City liquidated damages in the sum of **\$1,000 per day** for each and every calendar day completion of the Work and/or performance of all of the Contractor's obligations that have accrued pursuant to the Agreement is delayed beyond the Time for Completion. The

City and the Contractor further agree in accordance with California Government Code Section 53069.85 that the liquidated damages sum specified in this provision is not manifestly unreasonable under the circumstances existing at the time the Agreement was made, and that the City may deduct liquidated damages sums in accordance with this provision from any payments due or that may become due the Contractor under the Agreement.

**5-1.03 No Damage for Delay Beyond City and Contractor Control.** The Contractor will not be held responsible for delays in performance of the Work caused by delay beyond the control of both City and Contractor, such as by strikes, lockouts, or labor disturbances that are not within the control of the Contractor to resolve, lack or failure of transportation, or acts of other government entities. This provision will not apply where the delay would not have occurred but for a previous Contractor caused delay in the prosecution of the Work. The City will not be liable to the Contractor, any subcontractor or other entity engaged in the performance of the Work, any supplier, or any other person or organization, or to any surety or employee or agent of any of them, for damages arising out of or resulting from (i) delays beyond the control of the City and the Contractor including but not limited to fires, floods, epidemics, abnormal weather conditions, earthquakes and acts of God or acts or neglect by utility owners or other contractors performing other work, or (ii) delays caused by the City, its officials, officers, employees, agents, or volunteers, or delays caused by the Engineer or the Designer or Engineer, which delays are reasonable under the circumstances involved and/or are within the contemplation of the City and the Contractor. An extension of the Time for Performance in an amount equal to the time loss due to such delay(s) will be the Contractor's sole and exclusive remedy for such delay(s).

**5-1.04 No Damage for Contractor Caused Delay.** Contractor shall not be entitled to additional compensation for extended field or home office overhead, field supervision, costs of capital, interest, escalation charges, acceleration costs or other impacts for any delays to the extent such delays are caused by the failure of the Contractor or any subcontractor or other entity engaged in performance of the Work to perform the Work in accordance with the Contract Documents. Contractor may be eligible for additional compensation in excess of the Contract Price for delays caused by the City and/or its privities.

**5-1.05 No Damage for Other Delay.** Contractor will not be entitled to damages for delay to the Work caused by the following, which the City and Contractor agree will be deemed for purposes of California Public Contract Code Section 7102 either not caused by the City, and/or within the contemplation of the City and the Contractor, and/or reasonable under the circumstances:

- a. Exercise of the City's right to sequence the Work in a manner that would avoid disruption to the City and other contractors based on: (1) the failure of the Contractor or any subcontractor or other entity engaged in the performance of the Work to perform the Work in accordance with the Contract Documents, enforcement by the City or any other governmental agency of competent jurisdiction of any government act or regulation, or (2) enforcement by the City of any provisions of the Agreement.
- b. Requests for clarification or information concerning the Contract Documents or proposed Change Orders or modifications to the Contract Documents, including extensive and/or numerous such requests for clarification or information or proposed Change Orders or

modifications, provided such clarifications or information or proposed Change Orders or modifications are processed by the City or its representatives in a reasonable time in accordance with the Contract Documents.

**5-1.06 Delays Caused by the City and/or Its Privities.** Either the City or the Contractor may propose a change in the Time for Completion for delays that are purported to be caused by the City and/or its privities and that are not reasonable under the circumstances involved and/or that are not within the contemplation of the City and the Contractor. Such proposed changes in the Time for Completion will constitute Change Order proposals subject to Section 3 of these General Provisions. In accordance with Section 3 of these General Provisions, the City and the Contractor may agree upon pricing for the cost impacts, if any, resulting from such delays. If such pricing is in anticipation of cost impacts that may occur, but have not yet occurred, the City will be obligated to pay the Contractor for such anticipated impacts in accordance with the Agreement and any applicable, approved Change Orders only to the extent the Contractor actually incurs the anticipated cost impacts. Notwithstanding anything to the contrary in Section 3 of these General Provisions, the City and the Contractor may agree to a daily rate or cap or lump sum that will apply to the cost impacts, if any, resulting from delay purportedly caused by the City and/or its privities subject to this Section 5-1.06. However, if such daily rate or cap or lump sum is in anticipation of cost impacts that have not yet occurred, the City will be obligated to pay such daily rate or cap or lump sum only to the extent the Contractor actually incurs such cost impacts.

**5-1.07 Weather Delays.** Extensions of the Time for Completion will not be allowed for weather conditions that are consistent with the historical rain days reflected in historical weather data of the National Oceanographic and Atmospheric Administration (NOAA) of the U.S. Department of Commerce for the record station that is nearest or most applicable to the Work site. Extensions of the Time for Completion for delays due to adverse weather will be allowed only if the number of rain days exceeds those that can be anticipated based on the NOAA data and the Contractor can verify to the City's reasonable satisfaction that such adverse weather caused actual delay in the timely completion of the Work. No extensions of the Time for Completion will be granted for rain days that exceed those that can be anticipated based on the NOAA data and that merely result in delays that do not or would not, themselves, result in failure to complete the Work by the Time for Completion.

**5-1.08 Delay Claims.** Whenever the Contractor claims a delay for which the Time for Completion may be extended, the Contractor must request an extension of time within five (5) days of the start of the delay. The request must be in writing and describe in detail the cause for the delay, and, if possible, the foreseeable extent of the delay.

**5-1.09 Contractor Coordination of the Work.**

- a. The City reserves the right to do other work in connection with or in the vicinity of the Project by contract or otherwise, and Contractor shall at all times conduct the Work so as to impose no hardship on the City, others engaged in the Work or other contractors working at the Work site. The Contractor will adjust, correct and coordinate the Work with the work of others so that no delays result in the Work or other work at or near the Work site.



- b. If any part of the Work depends for proper execution or results upon the work of the City or any other contractor, the Contractor will, before proceeding with such Work, promptly report to the City any apparent discrepancies or defects in such other Work. Failure of the Contractor to promptly report any apparent discrepancy or defect will be deemed an acceptance of the City's or other contractor's Work as fit and proper.
- c. The Contractor will anticipate the relations of the various trades to the progress of the Work and will ensure that required anchorage or blocking is furnished and set at proper times. Anchorage and blocking necessary for each trade shall be part of the Work except where stated otherwise.
- d. The Contractor will provide proper facilities at all times for access of the City, the Engineer, Designer, and other authorized City representatives to conveniently examine and inspect the Work.
- e. Should construction be under way by other forces or by other contractors within or adjacent to the limits of the Work specified or should work of any other nature be under way by other forces within or adjacent to those limits, the Contractor shall cooperate with all the other contractors or other forces to the end that any delay or hindrance to their work will be avoided. The right is reserved to the City to perform other or additional work at or near the site (including material sources) at any time, by the use of other forces.
- f. When two (2) or more contractors are employed on related or adjacent work, or obtain materials from the same material source, each shall conduct their operations in such a manner as not to cause any unnecessary delay or hindrance to the other.
- g. Each contractor shall be responsible to the other for all damage to Work, to persons or property caused to the other by their operations, and for loss caused the other due to unnecessary delays or failure to finish the work within the time specified for completion.

**5-1.10 Differing Site Conditions.**

- a. During the progress of the Work, if subsurface or latent physical conditions are encountered at the site differing materially from those indicated in the Agreement or if unknown physical conditions of an unusual nature, differing materially from those ordinarily encountered and generally recognized as inherent in the Work, are encountered at the site, the Contractor shall promptly notify the City in writing of the specific differing conditions before they are disturbed and before the affected work is performed.
- b. Upon written notification, the Engineer will investigate the conditions, and if the Engineer determines that the conditions materially differ and cause an increase or decrease in the cost or time required for the performance of any Work, an adjustment, excluding loss of anticipated profits, will be made and the Agreement modified in writing accordingly. The Engineer will notify the Contractor of the Engineer's determination whether or not an adjustment of the contract is warranted.

- c. No Agreement adjustment that results in a benefit to the Contractor will be allowed unless the Contractor has provided the written notice required in this Section 5-1.10.
- d. Any Agreement adjustment warranted due to differing site conditions will be made in accordance with the provisions in Section 3 of these General Provisions, “Changes in Work,” except as otherwise provided.

**5-1.11 Relief From Maintenance And Responsibility.**

- a. Upon the request of the Contractor, the City may relieve the Contractor of the duty of maintaining and protecting certain portions of the Work, which have been completed in all respects in accordance with the requirements of the Agreement and to the satisfaction of the Engineer, and thereafter except with the Contractor's consent, the Contractor will not be required to do further Work thereon. In addition, such action by the City will relieve the Contractor of responsibility for injury or damage to those completed portions of the Work resulting from use by public traffic or from the action of the elements or from any other cause but not from injury or damage resulting from the Contractor's own operations or from the Contractor's negligence.
- b. However, nothing in this Section 5-1.11 providing for relief from maintenance and responsibility will be construed as relieving the Contractor of full responsibility for making good any defective Work or materials found at any time before the formal written acceptance of the entire Agreement by the City.

**SECTION 6  
CONTRACTOR RESPONSIBILITIES**

- 6-1.01 Eligibility.** By executing the Agreement, the Contractor certifies that the Contractor is not ineligible to perform work on public works projects pursuant to California Labor Code Sections 1777.1 or 1777.7. In accordance with California Public Contract Code Section 6109(a), contractors who are ineligible to perform work on public works projects pursuant to California Labor Code Sections 1777.1 or 1777.7 may neither bid on, be awarded or perform the Work. To the full extent permitted by law the Contractor shall hold harmless and indemnify the City from and against any and all damages, costs, and liability arising from or as a consequence of any violation of Public Contract Code Section 6109.
- 6-1.02 Supervision of the Work.** The Contractor will be solely responsible for the performance of the Work, including portions of the Work to be performed by subcontractors. The Contractor is charged with ensuring that all orders or instructions from the City, Engineer or Designer are disseminated to and followed by all subcontractors engaged in performance of the Work. The Contractor will supervise the Work using the Contractor's best skill and attention. At any time during the progress of the Work, the City, the Engineer, or the Designer may require the Contractor and/or subcontractors engaged in performance of the Work to attend a project meeting and the Contractor will attend, and ensure the attendance of any subcontractors whose attendance is required by the City and/or advisable in light of the matters to be addressed at the meeting.
- 6-1.03 Contractor's Superintendent.** The Contractor will keep on the Work, throughout its progress, a competent superintendent and any necessary assistants, all satisfactory to the City. The Contractor shall designate in writing before starting Work the superintendent who shall have the authority to represent and act for the Contractor. The authorized representative shall be present at the site of the Work at all times while work is actually in progress. When Work is not in progress and during periods when Work is suspended, arrangements acceptable to the Engineer shall be made for any emergency Work that may be required. Whenever the Contractor or the Contractor's authorized representative is not present on any particular part of the Work where it may be desired to give direction, orders will be given by the Engineer, which shall be received and obeyed by the superintendent or foreman who may have charge of the particular Work in reference to which the orders are given. Any order given by the Engineer, not otherwise required by the specifications to be in writing, will on request of the Contractor, be given or confirmed by the Engineer in writing. The superintendent may not be changed without the consent of the City. The superintendent will represent the Contractor and all directions given by the City to the superintendent will bind the Contractor in accordance with the Agreement. Superintendent time included in Contractor's completed bid schedule and/or in approved Change Orders, if any, must be included in Contractor's approved overhead rate and may not be charged as a direct cost.
- 6-1.04 Competent Employees.** The Contractor must at all times enforce strict discipline and good order among the Contractor's employees and may not employ on the Work any unfit person or anyone not skilled in the Work assigned, or anyone incompetent or unfit for the duties of that person. When the City determines that a Contractor employee does not satisfy the requirements of this Section 6-1.04, upon notice from the City, the Contractor must ensure that

employee performs no further Work and is no longer present at the Work site. Any such Contractor employee may not again be employed on the Work without City approval. If any subcontractor or person employed by the Contractor shall appear to the Engineer to be incompetent or to act in a disorderly or improper manner, they shall be discharged immediately on the request of the Engineer, and that person shall not again be employed on the work.

**6-1.05 Items Necessary for Proper Completion of the Work.** Except as otherwise noted in the Contract Documents, the Contractor will provide and pay for all labor, materials, equipment, permits, fees, licenses, facilities and services necessary for the proper execution and timely completion of the Work in accordance with the Contract Documents.

**6-1.06 Construction Reports.** The Contractor must submit daily construction logs detailing the daily progress of the Work to the Engineer on a weekly basis.

**6-1.07 Subcontracting.**

- a. By executing the Agreement, the Contractor certifies that no subcontractor included on the list of proposed subcontractors submitted with the Contractor's bid is ineligible to perform work on public works projects pursuant to California Labor Code Sections 1777.1 or 1777.7. In accordance with California Public Contract Code Section 6109(a), subcontractors who are ineligible to perform work on public works projects pursuant to California Labor Code Sections 1777.1 or 1777.7 may neither bid on, be awarded or perform as a subcontractor on the Work. In accordance with California Public Contract Code Section 6109(b), any contract on a public works project entered into between a contractor and a debarred subcontractor is void as a matter of law. The Contractor will ensure that no debarred subcontractor receives any public money for performing the Work, and that any public money that may have been paid to a debarred subcontractor for the Work is returned to the City. The Contractor will be responsible for payment of wages to workers of a debarred subcontractor who has been allowed to perform the Work.
- b. The Agreement and the performance of the Work are subject to the requirements of the Subletting and Subcontracting Fair Practices Act codified at California Public Contract Code Section 4100 and following. If the Contractor fails to specify a subcontractor or specifies more than one subcontractor for the same portion of the Work in excess of one-half of 1 percent of the Contractor's total bid, the Contractor agrees that the Contractor is fully qualified to perform that portion of the Work with the Contractor's own forces, and that the Contractor will perform that portion of the Work with the Contractor's own forces. If after award of the Agreement the Contractor subcontracts, except as provided for in California Public Contract Code Sections 4107 or 4109, any such portion of the Work, the Contractor will be subject to the penalties set forth in California Public Contract Code Sections 4110 and 4111, including cancellation of the Agreement, assessment of a penalty of up to 10 percent of the amount of the subcontract, and disciplinary action by the Contractors State License Board.
- c. No contractual relationship exists between the City and any subcontractor engaged in performance of the Work.

- d. Incorporation of Contract Documents. The Contractor must incorporate the Contract Documents in each contract with a subcontractor engaged in the performance of the Work. The Contractor will be solely responsible for any delay or additional costs incurred as a result of its failure to provide adequate or accurate project information to a subcontractor that results in improper submittals and/or work, or time or other impacts. The Contractor will have all of the obligations and the City will have all of the remedies that are specified in Section 9 of these General Provisions concerning any subcontracted work. Subcontracts shall also contain certification by the subcontractor that the subcontractor is experienced in and qualified to do, and knowledgeable about, the subcontracted Work. Copies of subcontracts shall be available to the Engineer upon written request, and shall be provided to the Engineer at the time any litigation against the City concerning the project is filed.
- e. Coordination of Subcontract Work: The Contractor is responsible for scheduling the Work of subcontractors so as to avoid delay or injury to either Work or materials.
- f. The Contractor shall give personal attention to the fulfillment of the Contract and shall keep the work under the Contractor's control.
- g. The Contractor shall perform, with the Contractor's own organization, contract Work amounting to not less than 50 percent of the original total contract price, except that any designated "Specialty Items" may be performed by subcontract and the amount of any designated "Specialty Items" performed by subcontract may be deducted from the original total contract price before computing the amount of Work required to be performed by the Contractor with the Contractor's own organization. When items of Work in the Engineer's Estimate are preceded by the letters (S) or (S-F), those items are designated as "Specialty Items." Where an entire item is subcontracted, the value of Work subcontracted will be based on the Agreement item bid price. When a portion of an item is subcontracted, the value of Work subcontracted will be based on the estimated percentage of the Agreement item bid price, determined from information submitted by the Contractor, subject to approval by the Engineer.
- h. Before Work is started on a subcontract, the Contractor shall file with the Engineer a written statement showing the Work to be subcontracted, the names of the subcontractors and the description of each portion of the Work to be subcontracted.
- i. Pursuant to the provisions of Section 6109 of the Public Contract Code, the Contractor shall not perform Work on a public works project with a subcontractor who is ineligible to perform Work on the public works project pursuant to Section 1777.1 or 1777.7 of the Labor Code.
- j. When a portion of the Work which has been subcontracted by the Contractor is not being prosecuted in a manner satisfactory to the City, the subcontractor shall be removed immediately on the request of the City and shall not again be employed on the Work.
- k. The roadside production of materials produced by other than the Contractor's forces shall be considered as subcontracted. Roadside production of materials shall be construed to be production of aggregates of all kinds with portable, semiportable or temporary crushing or

screening, proportioning and mixing plants established or reopened for the purpose of supplying aggregate or material for a particular project or projects. The erection, establishment or reopening of the plants and the operation thereof in the production of materials for use on the Work shall conform to the requirements relating to labor set forth in these General Provisions and in the Special Provisions.

**6-1.08 Insurance.**

Contractor shall procure and maintain for the duration of the Contract insurance against claims for injuries to persons or damages to property which may arise from or in connection with the performance of the Work hereunder by the Contractor, his agents, representatives, employees or subcontractors.

- a. All required insurance shall be provided in the form of “occurrence”-type policies underwritten by admitted insurers in the State of California with a rating of A:VII or better from the current year Best Rating Guide. All policies must be issued at the expense of the Contractor and must be maintained at the Contractor’s expense throughout the performance of the Work.
- b. The Contractor and any subcontractors engaged in performance of the Work must secure payment of workers compensation in accordance with California Labor Code Section 3700 and other applicable law. The Contractor must verify that all Subcontractors comply with this requirement.
- c. Within ten working days following date of notice of award the Contractor must submit to the Agency along with executed copies of all other documents specified in the Contract Check List certificates of insurance and endorsements evidencing that the Contractor has in effect and will maintain throughout the performance of the Work the following kinds and amounts of insurance against claims for injuries to persons or damages to property which may arise from or in connection with the performance of the work hereunder by the Contractor, his agents, representatives, employees or subcontractors:

Minimum Scope of Insurance

Coverage shall be at least as broad as:

- 1. Insurance Services Office Commercial General Liability coverage (occurrence form CG 0001).
- 2. Insurance Services Office form number CA 0001 (Ed. 1/87) covering Automobile Liability, code 1 (any auto).
- 3. Workers’ Compensation insurance as required by the State of California and Employer’s Liability Insurance.
- 4. **Coverage shall not extend to any indemnity coverage for the active negligence of the additional insured in any case where an agreement to indemnify the additional insurance would be invalid under Subsection (b) of Section 2782 of the Civil Code.**

Minimum Limits of Insurance

Contractor shall maintain limits no less than:

1. General Liability: \$2,000,000 per occurrence for bodily injury, personal injury and property damage **including operations, products and completed operations**. If Commercial General Liability Insurance or other form with a general aggregate limit is used, either the general aggregate limit shall apply separately to this project/location or the general aggregate limit shall be twice the required occurrence limit.
2. Automobile Liability: \$2,000,000 per accident for bodily injury and property damage.
3. Employer's Liability: \$1,000,000 per accident for bodily injury or disease.

**Deductibles and Self-Insured Retentions**

Any deductibles or self-insured retentions must be declared to and approved by the City. At the option of the City, either: (1) the insurer shall reduce or eliminate such deductibles or self-insured retentions as respects the City, its officers, officials, employees and volunteers; or (2) the Contractor shall provide a financial guarantee satisfactory to the City guaranteeing payment of losses and related investigations, claim administration and defense expenses.

**Other Insurance Provisions**

The general liability and automobile liability policies are to contain, or be endorsed to contain, the following provisions:

1. The City, its officers, officials, employees, and volunteers are to be covered as additional insureds with respect to liability arising out of automobiles and other vehicles owned, leased, hired or borrowed by or on behalf of the contractor; and with respect to liability arising out of work or operations performed by or on behalf of the Contractor including materials, parts or equipment furnished in connection with such work or operations. General and auto liability coverage can be provided in the form of an endorsement to the Contractor's insurance, or as a separate owner's policy.
2. For any claims related to this project, the Contractor's insurance coverage shall be primary insurance as respects the City, its officers, officials, employees, and volunteers. Any insurance or self-insurance maintained by the City, its officers, officials, employees, or volunteers shall be excess of the Contractor's insurance and shall not contribute with it.
3. Each insurance policy required by this clause shall be endorsed to state that coverage shall not be canceled by either party, except after thirty (30) days' prior written notice by certified mail, return receipt requested, has been given to the City.
4. **Coverage shall not extend to any indemnity coverage for the active negligence of the additional insured in any case where an agreement to indemnify the additional insured would be invalid under Subsection (b) of Section 2782 of the Civil Code.**

**Waiver of Subrogation**

The worker's compensation policy is to be endorsed with a waiver of subrogation. The insurance company, in its endorsement, agrees to waive all rights against the City, its officers, officials, employees and volunteers for losses paid under the terms of this policy which arise from the work performed by the named insured for the City.

Verification of Coverage

Contractor shall furnish the City with original certificates and amendatory endorsements as approved by the City effecting coverage required by this clause. The endorsements should be on forms provided by the City or on other than the City's forms, provided those endorsements or policies conform to the requirements. All certificates and endorsements are to be received and approved by the City before work commences. The City reserves the right to require complete, certified copies of all required insurance policies, including endorsements effecting the coverage required by these specifications at any time.

Subcontractors

Contractor shall include all subcontractors as insureds under its policies or shall furnish separate certificates and endorsements for each subcontractor. All coverages for subcontractors shall be subject to all of the requirements stated herein.

- d. For each insurance policy required under the Agreement (except for the required workers compensation insurance policy) the Contractor must provide endorsements that add the City, its officers, officials, employees and volunteers as an additional insured. Such endorsements must: provide that the insurance required to be furnished by the Contractor will be primary as regards the City, and that the City's insurance will be excess of and not contribute to the insurance required to be furnished by the Contractor; that the City will receive 30 day written notice of any reduction or cancellation of such insurance required to be furnished by the Contractor; and include a severability of interest clause acceptable to the City. Said endorsement shall be at least as broad as Insurance Services Office form number CG2010 (Ed. 11/85).

**6-1.09 Indemnities.**

- a. The Contractor will take all responsibility for the Work, and will bear all losses and damages directly or indirectly resulting to the Contractor, any subcontractors engaged in performance of the Work, the City, its officials, officers, employees, agents, volunteers and consultants, and to third parties on account of the performance or character of the Work, unforeseen difficulties, accidents, or occurrences of other causes predicated on active or passive negligence of the Contractor or of any subcontractor engaged in performance of the Work. To the fullest extent permitted by law the Contractor will indemnify, defend and hold harmless the City, its officials, officers, employees, agents, volunteers and consultants from and against any or all loss, liability, expense, claims, costs (including costs of defense), suits, and damages of every kind, nature and description (including, but not limited to, penalties resulting from exposure to hazards in violation of the California Labor Code) directly or indirectly arising from the performance of the Work ("Claims").
- b. The Contractor will indemnify, defend and hold harmless the City, the City's officials, officers, employees, volunteers, agents and the Engineer and Designer for all liability on account of any patent rights, copyrights, trade names or other intellectual property rights that may apply to the Contractor's performance of the Work. The Contractor will pay all royalties or other charges as a result of intellectual property rights that may apply to methods, types of construction, processes, materials, or equipment used in the performance



of the Work, and will furnish written assurance satisfactory to the City that any such charges have been paid.

- c. The Contractor assumes all liability for any accident or accidents resulting to any person or property as a result of inadequate protective devices for the prevention of accidents in connection with the performance of the Work. The Contractor will indemnify, defend, and hold harmless the City and its officials, officers, employees, agents, volunteers and consultants from such liability.
- d. Approval of the Contractor's certificates of insurance and/or endorsements does not relieve the Contractor of liability under Sections 6-1.08 or 6-1.09 hereof. The Contractor will defend, with legal counsel reasonably acceptable to the City, any action or actions filed in connection with any Claims and will pay all related costs and expenses relating thereto, including attorney's fees incurred. The Contractor will promptly pay any judgment rendered against the City, its officials, officers, employees, agents, volunteers or consultants for any Claims. In the event the City, its officials, officers, employees, agents, volunteers or consultants is made a party to any action or proceeding filed or prosecuted against Contractor for any Claims, Contractor agrees to pay the City, its officials, officers, employees, agents, volunteers and consultants any and all costs and expenses incurred in such action or proceeding, including but not limited to, reasonable attorneys' fees. "Claims" as used herein shall include all demands or requests for payment, reimbursement or damages whatsoever in any way involving the Agreement or the Work related thereto.
- e. In accordance with California Civil Code Section 2782(a), nothing in the Agreement will be construed to indemnify the City for its sole negligence, willful misconduct, or for defects in design furnished by City. In accordance with California Civil Code Section 2782(b), nothing in the Agreement will be construed to impose on the Contractor or to relieve the City from liability for the City's active negligence. By execution of the Contract Documents the Contractor acknowledges and agrees that the Contractor has read and understands the insurance and indemnity requirements of the Contract Documents, which are material elements of consideration.

**6-1.10 Licenses/Permits.** The Contractor must, without additional expense to the City, obtain all licenses, permits and other approvals required for the performance of the Work.

**6-1.11 California Labor Code Requirements.**

- a. In accordance with California Labor Code Section 1810, eight (8) hours of labor in performance of the Work shall constitute a legal day's work under the Agreement.
- b. In accordance with California Labor Code Section 1811, the time of service of any worker employed in performance of the Work is limited to eight hours during any one calendar day, and forty hours during any one calendar week, except in accordance with California Labor Code Section 1815, which provides that work in excess of eight hours during any one calendar day and forty hours during any one calendar week is permitted upon compensation for all hours worked in excess of eight hours during any one calendar day and forty hours during any one calendar week at not less than one-and-one-half times the basic rate of pay.

- c. The Contractor and its subcontractors will forfeit as a penalty to the City \$25 for each worker employed in the performance of the Work for each calendar day during which the worker is required or permitted to work more than eight (8) hours in any one calendar day, or more than forty (40) hours in any one calendar week, in violation of the provisions of California Labor Code Section 1810 et seq.
- d. In accordance with California Labor Code Section 1773.2, the City has determined the general prevailing wages in the locality in which the Work is to be performed for each craft or type of work needed to be as published by the State of California Department of Industrial Relations, Division of Labor Statistics and Research, a copy of which is on file in the Public Works Department and shall be made available on request. The Contractor and subcontractors engaged in the performance of the Work shall pay no less than these rates to all persons engaged in performance of the Work.
- e. In accordance with California Labor Code Section 1775, the Contractor and any subcontractors engaged in performance of the Work must comply with Labor Code Section 1775, which establishes a penalty of up to \$200 per day for each worker engaged in the performance of the Work that the Contractor or any subcontractor pays less than the specified prevailing wage. The amount of such penalty shall be determined by the Labor Commissioner. The Contractor or subcontractor shall pay the difference between the prevailing wage rates and the amount paid to each worker for each calendar day or portion thereof for which each worker was paid less than the prevailing wage rate. If a subcontractor worker engaged in performance of the Work is not paid the general prevailing per diem wages by the subcontractor, the Contractor is not liable for any penalties therefore unless the Contractor had knowledge of that failure or unless the Contractor fails to comply with all of the following requirements:
  - 1. The contract executed between the Contractor and the subcontractor for the performance of part of the Work must include a copy of the provisions of California Labor Code Sections 1771, 1775, 1776, 1777.5, 1813, and 1815.
  - 2. The Contractor must monitor payment of the specified general prevailing rate of per diem wages by the subcontractor by periodic review of the subcontractor's certified payroll records.
  - 3. Upon becoming aware of a subcontractor's failure to pay the specified prevailing rate of wages, the Contractor must diligently take corrective action to halt or rectify the failure, including, but not limited to, retaining sufficient funds due the subcontractor for performance of the Work.
  - 4. Prior to making final payment to the subcontractor, the Contractor must obtain an affidavit signed under penalty of perjury from the subcontractor that the subcontractor has paid the specified general prevailing rate of per diem wages employees engaged in the performance of the Work and any amounts due pursuant to California Labor Code Section 1813 and a copy of such affidavit shall be provided to the Engineer within 14 days of its execution by the subcontractor.

5. In accordance with California Labor Code Section 1771.4, the project is subject to compliance monitoring and enforcement by the Department of Industrial Relations. In accordance with California Labor Code Section 1776, the Contractor and each subcontractor engaged in performance of the Work, must keep accurate payroll records showing the name, address, social security number, work classification, straight time and overtime hours worked each day and week, and the actual per diem wages paid to each journeyman, apprentice, worker, or other employee employed in performance of the Work. Each payroll record must contain or be verified by a written declaration that it is made under penalty of perjury, stating that the information contained in the payroll record is true and correct and that the employer has complied with the requirements of Sections 1771, 1811, and 1815 for any work performed by the employer's employees on the public works project. The payroll records required pursuant to California Labor Code Section 1776 must be certified and must be available for inspection by the City and its authorized representatives, the Division of Labor Standards Enforcement, and the Division of Apprenticeship Standards of the Department of Industrial Relations and must otherwise be available for inspection in accordance with California Labor Code Section 1776. In addition, in accordance with California Labor Code Section 1771.4, the Contractor and its subcontractor(s) shall furnish the records specified in California Labor Code Section 1776 directly to the Labor Commissioner at least monthly (or more frequently if specified in the Contract Documents); and in a format prescribed by the Labor Commissioner.
  
6. In accordance with California Labor Code Section 1771.4, the Contractor shall post job site notices, as prescribed by regulation.
  
- f. By executing the Agreement, in accordance with California Labor Code Section 1771(a), the Contractor represents that it and all of its Subcontractors are currently registered and qualified to perform public work pursuant to Labor Code Section 1725.5. The Contractor covenants that any additional or substitute Subcontractors will be similarly registered and qualified.
  
- g. In accordance with California Labor Code Section 1777.5, the Contractor, on behalf of the Contractor and any subcontractors engaged in performance of the Work, will be responsible for ensuring compliance with California Labor Code Section 1777.5 governing employment and payment of apprentices on public works contracts.
  
- h. In case it becomes necessary for the Contractor or any subcontractor engaged in performance of the Work to employ on the Work any person in a trade or occupation (except executive, supervisory, administrative, clerical, or other non manual workers as such) for which no minimum wage rate has been determined by the Director of the Department of Industrial Relations, the Contractor must pay the minimum rate of wages specified therein for the classification which most nearly corresponds to Work to be performed by that person. The minimum rate thus furnished will be applicable as a minimum for such trade or occupation from the time of the initial employment of the person affected and during the continuance of such employment.

**6-1.12 Laws and Ordinances.** The Contractor and all subcontractors engaged in the performance of the Work must conform to the following specific rules and regulations as well as all other laws, ordinances, rules and regulations that apply to the Work. Nothing in the Technical Specifications or Project Plans is to be construed to permit Work not conforming to these codes:

- National Electrical Safety Code, U. S. Department of Commerce
- National Board of Fire Underwriters' Regulations
- California Building Standards Code as adopted by the City
- Manual of Accident Prevention in Construction, latest edition, published by A.G.C. of America
- Industrial Accident Commission's Safety Orders, State of California
- Regulations of the State Fire Marshall (Title 19, California Code of Regulation) and Applicable Local Fire Safety Codes
- Labor Code of the State of California - Division 2, Part 7, Public Works and Public Agencies.

**6-1.13 Guaranty.** The Contractor guarantees all of the Work for one year from the date the City accepts the Work. Upon receiving written notice of a need for repairs which are directly attributable to defective materials or workmanship the Contractor must make good any defects arising or discovered in any part of the Work by diligently commencing the necessary repairs within seven (7) days from the date of notice from the City. If the Contractor fails to make good any defects in the Work in accordance with this Section 6-1.13, in addition to any other available remedy under the contract or at law or equity, the City may make good or have made good such defects in the Work and deduct the cost from amounts that may be due or become due the Contractor, and/or call on the Contractor's maintenance bond for the cost of making good such defects and for the City's reasonable legal costs, if any, of recovering against the bond. The Contractor will remain responsible for repairing any Work found to be defective regardless of when such defect is discovered by the City.

**6-1.14 Safety.**

- a. In accordance with generally accepted construction practices and applicable law, the Contractor will be solely and completely responsible for conditions of the Work site, including safety of all persons and property during performance of the Work. This requirement will apply continuously and not be limited to normal working hours. For purposes of California Labor Code Section 6400 and related provisions of law, the Contractor and the Contractor's privities and any other entities engaged in the performance of the Work will be "employers" responsible for furnishing employment and a place of employment that is safe and healthful for the employees, if any, of such entities engaged in the performance of the Work. Neither the City nor its officials, officers, employees, agents, volunteers or consultants will be "employers" pursuant to California Labor Code Section 6400 and related provisions of law with respect to the Contractor, the Contractor's privities or other entities engaged in the performance of the Work.
- b. Review and inspection by the City, the Designer or the Engineer, and/or other representatives of the City of the Contractor's performance of the Work will not constitute

review of the adequacy of the Contractor's safety measures in, on, or near the Work site. Such reviews and inspections do not relieve the Contractor of any of the Contractor's obligations under the Contract Documents and applicable law to ensure that the Work site is maintained and the Work is performed in a safe manner.

- c. The Contractor will be solely responsible for the implementation and maintenance of safety programs to ensure that the Work site is maintained and the Work is performed in a safe manner in accordance with the Contract Documents and applicable law.
- d. Within ten (10) working days following date of notice of award the Contractor must submit to the City a copy of the Contractor's Safety Plan.
- e. The Contractor must furnish and place proper guards and systems for the prevention of accidents, including, but not limited to, those systems required pursuant to Title 8, Section 1670 and following Sections of the California Code of Regulations concerning safety belts and nets. The Contractor must provide and maintain any other necessary systems or devices required to secure safety of life or property at the Work site in accordance with accepted standards of the industry and applicable law. The Contractor must maintain during all night hours sufficient lights to prevent accident or damage to life or property.

**6-1.15 Load Limitations.**

- a. Unless expressly permitted in the Special Provisions, construction equipment or vehicles of any kind which, laden or unladen, exceed the maximum weight limitations set forth in Division 15 of the Vehicle Code, shall not be operated over completed or existing treated bases, surfacing, pavement or structures in any areas within the limits of the Project.
- b. After application of the curing seal, no traffic or Contractor's equipment will be permitted on cement treated base or lean concrete base for a period of 72 hours. After 72 hours, traffic and equipment operated on the base shall be limited to that used in paving operations and placing additional layers of cement treated base. No traffic or Contractor's equipment will be permitted on treated permeable base except for that equipment required to place the permeable base and the subsequent layer of pavement. Trucks used to haul treated base, portland cement concrete, or asphalt concrete shall enter onto the base to dump at the nearest practical entry point ahead of spreading equipment. Empty haul trucks shall exit from the base at the nearest practical exit point. Entry and exit points shall not be more than 1,000 feet ahead of spreading equipment except in locations where specifications prohibit operation of trucks outside the area occupied by the base or where steep slopes or other conditions preclude safe operation of hauling equipment. In those locations, entry and exit points shall be established at the nearest point ahead of spreading equipment permitted by specifications and allowing safe operation of hauling equipment. Damage to curing seal or base shall be repaired promptly by the Contractor, at the Contractor's expense, as directed by the Engineer.
- c. Within the limits of the Project and subject to the control of the Engineer, and provided that the Contractor, at the Contractor's expense, shall provide such protective measures as are

deemed necessary by the Engineer and shall repair any damage caused by the operations, the Contractor will be permitted to:

1. Make transverse crossings of those portions of an existing public road or street that are within the highway right of way, with construction equipment that exceeds the size or weight limitations set forth in Division 15 of the Vehicle Code.
2. Make transverse crossings of treated bases, surfacing or pavement which are under construction or which have been completed, with construction equipment which exceeds the size or weight limitations set forth in Division 15 of the Vehicle Code.
3. Cross bridge structures that are not open to public traffic and that are designed for HS20-44 Live Loading (culverts and pipes excluded), with construction equipment which exceeds the size or weight limitations set forth in Division 15 of the Vehicle Code, but not exceeding the load limitations hereinafter specified, provided that the Contractor furnishes to the Engineer the dimensions and maximum axle loadings of equipment proposed for use on bridge structures:
  - A. The maximum loading on bridge structures due to pneumatic-tired truck and trailer combinations shall not exceed (1) 28,000 pounds for single axles, (2) 48,000 pounds for tandem axles, nor (3) 60,000 pounds total gross load for single vehicles or 110,000 pounds total gross load for truck and trailer or semi-trailer combinations.
  - B. The loading on bridge structures due to 2 and 3 axle pneumatic-tired earthmovers shall not exceed that shown in the following table.

Allowable Construction Loading On Bridges For 2 and 3 Axle Earthmovers

Spacing of Bridge Girders (center to center in feet)	Maximum Axle Loading (in pounds)
4	28,000
5	29,000
6	30,0
7	32,000
8	34,000
9	37,000
10 and over	40,000

Minimum axle spacing:

For 3-axle earthmovers

Axles 1 to 2 = 8 feet

Axles 2 to 3 = 20 feet

For 2-axle earthmovers

Axles 1 to 2 = 20 feet

4. Move equipment within the limits of the Project over completed or existing base, surfacing, pavement and structures, whether or not open to the public.

- d. Within the limits of the Project and subject to the condition that the Contractor shall repair, at the Contractor's expense, any damage caused thereby, the Contractor will be permitted to cross culverts and pipes with construction equipment that exceeds the size or weight limitations set forth in Division 15 of the Vehicle Code in accordance with the conditions set forth on the Project Plans.
- e. Should the Contractor desire to increase the load carrying capacity of a structure or structures which are to be constructed as a part of the Agreement, in order to facilitate the Contractor's own operations, the Contractor may request the Engineer to consider redesigning the structure or structures. Proposals by the Contractor to increase the load carrying capacity of structures above 130,000 pounds per single axle or pair of axles less than 8 feet apart, or above 330,000 pounds total gross vehicle weight, will not be approved. The request shall include a description of the structure or structures involved and a detailed description of the overloads to be carried, the date the revised plans would be required, and a statement that the Contractor agrees to pay all costs involved in the strengthening of the structure or structures, including the cost of revised plans, and further that the Contractor agrees that no extension of time will be allowed by reason of any delay to the work which may be due to the alteration of the structure or structures. If the Engineer determines that strengthening the structure or structures will be permitted, the Engineer will inform the Contractor of the estimated cost of the alterations, including engineering, and the date that revised plans could be furnished. If the cost and date are satisfactory to the Contractor, the Engineer will prepare a Change Order providing for the agreed upon alterations.

**6-1.16 Public Convenience.**

- a. The Contractor shall so conduct operations as to offer the least possible obstruction and inconvenience to the public and shall have under construction no greater length or amount of Work than can be prosecuted properly with due regard to the rights of the public.
- b. Unless otherwise provided in the Special Provisions, all public traffic shall be permitted to pass through the Work with as little inconvenience and delay as possible. Where possible, public traffic shall be routed on new or existing paved surfaces.
- c. Spillage resulting from hauling operations along or across any public traveled way shall be removed immediately by the Contractor at the Contractor's expense.
- d. Existing traffic signals and highway lighting shall be kept in operation for the benefit of the traveling public during progress of the Work, and other forces will continue routine maintenance of existing systems.
- e. Construction operations shall be conducted in such a manner as to cause as little inconvenience as possible to abutting property owners.
- f. Convenient access to driveways, houses, and buildings along the line of the Work shall be maintained and temporary approaches to crossings or intersecting highways shall be provided and kept in good condition. When the abutting property owner's access across the right of way line is to be eliminated, or to be replaced under the Contract by other access

facilities, the existing access shall not be closed until the replacement access facilities are usable.

- g. The Contractor may be required to cover certain signs which regulate or direct public traffic to roadways that are not open to traffic. The Engineer will determine which signs shall be covered.
- h. Roadway excavation and the construction of embankments shall be conducted in such a manner as to provide a reasonably smooth and even surface satisfactory for use by public traffic at all times; sufficient fill at culverts and bridges to permit traffic to cross shall be placed in advance of other grading operations; and if ordered by the Engineer roadway cuts shall be excavated in lifts and embankments constructed part width at a time, construction being alternated from one side to the other and traffic routed over the side opposite the one under construction. Culvert installation or culvert construction shall be conducted on but one-half the width of the traveled way at a time, and that portion of the traveled way being used by public traffic shall be kept open and unobstructed until the opposite side of the traveled way is ready for use by traffic.
- i. Upon completion of rough grading at the grading plane, or placing any subsequent layer thereon, the surface of the roadbed shall be brought to a smooth, even condition free of humps and depressions, satisfactory for the use of public traffic.
- j. After the surface of the roadbed has been brought to a smooth and even condition for the passage of public traffic as above provided, any work ordered by the Engineer for the accommodation of public traffic prior to commencing subgrade operations will be paid for as extra work as provided in Section 3 of the General Provisions. After subgrade preparation for a specified layer of material has been completed, the Contractor shall, at the Contractor's expense, repair any damage to the roadbed or completed subgrade, including damage caused by the Contractor's operations or use by public traffic.
- k. While subgrade and paving operations are underway, public traffic shall be permitted to use the shoulders and, if half-width paving methods are used, shall also be permitted to use the side of the roadbed opposite the one under construction. When sufficient width is available, a passageway wide enough to accommodate at least 2 lanes of traffic shall be kept open at locations where subgrade and paving operations are in active progress.
- l. When ordered by the Engineer, the Contractor shall furnish a pilot car and driver and flaggers for the purpose of expediting the passage of public traffic through the Work under one-way controls. At locations where traffic is being routed through construction under one-way controls and when ordered by the Engineer, the movement of the Contractor's equipment from one portion of the Work to another shall be governed in accordance with the one-way controls.
- m. Water or dust palliative shall be applied if ordered by the Engineer for the alleviation or prevention of dust nuisance.



- n. In order to expedite the passage of public traffic through or around the work and where ordered by the Engineer, the Contractor shall install signs, lights, flares, temporary railing (Type K), barricades and other facilities for the sole convenience and direction of public traffic. Also where directed by the Engineer, the Contractor shall furnish competent flaggers whose sole duties shall consist of directing the movement of public traffic through or around the Work. The cost of furnishing and installing the signs, lights, flares, temporary railing (Type K), barricades, and other facilities, not to be paid for as separate contract items, will be paid for as provided in Section 3 of the General Provisions.
- o. The Contractor will be required to pay the cost of replacing or repairing all facilities installed for the convenience or direction or warning of public traffic that are lost while in the Contractor's custody, or are damaged by reason of the Contractor's operations to such an extent as to require replacement or repair, and deductions from any moneys due or to become due the Contractor will be made to cover the cost thereof.
- p. Whenever a section of surfacing, pavement or the deck of a structure has been completed, the Contractor shall open it to use by public traffic if the Engineer so orders or may open it to use by public traffic if the Engineer so consents. In either case the Contractor will not be allowed any compensation due to any delay, hindrance or inconvenience to the Contractor's operations caused by public traffic, but will thereupon be relieved of responsibility for damage to completed permanent facilities caused by public traffic, within the limits of that use. The Contractor will not be relieved of any other responsibility under the Contract nor will the Contractor be relieved of cleanup and finishing operations.
- q. Except as otherwise provided in this Section 6.1-16 or in the Special Provisions, full compensation for conforming to the provisions in this Section 6.1-16 shall be considered as included in the prices paid for the various contract items of Work and no additional compensation will be allowed therefor.

**6-1.17 Public Safety.**

- a. It is the Contractor's responsibility to provide for the safety of traffic and the public during construction.
- b. Whenever the Contractor's operations create a condition hazardous to traffic or to the public, the Contractor shall, at the Contractor's expense and without cost to the City, furnish, erect and maintain those fences, temporary railing (Type K), barricades, lights, signs and other devices and take such other protective measures that are necessary to prevent accidents or damage or injury to the public.
- c. Fences, temporary railing (Type K), barricades, lights, signs, and other devices furnished, erected and maintained by the Contractor, at the Contractor's expense, are in addition to any construction area traffic control devices for which payment is provided for elsewhere in the Agreement.
- d. The Contractor shall also furnish such flaggers as are necessary to give adequate warning to traffic or to the public of any dangerous conditions to be encountered.

- e. Signs, lights, flags, and other warning and safety devices and their use shall conform to the requirements set forth in Chapter 6 of the MUTCD. Signs or other protective devices furnished and erected by the Contractor, at the Contractor's expense, as above provided, shall not obscure the visibility of, nor conflict in intent, meaning and function of either existing signs, lights and traffic control devices or any construction area signs and traffic control devices for which furnishing of, or payment for, is provided elsewhere in the Agreement. Signs furnished and erected by the Contractor, at the Contractor's expense, shall be approved by the Engineer as to size, wording and location.
- f. The installation of general roadway illumination shall not relieve the Contractor of the responsibility for furnishing and maintaining any of the protective facilities herein before specified.
- g. Construction equipment shall enter and leave the highway via existing ramps and crossovers and shall move in the direction of public traffic. All movements of workmen and construction equipment on or across lanes open to public traffic shall be performed in a manner that will not endanger public traffic.
- h. The Contractor's trucks or other mobile equipment which leave a freeway lane, that is open to public traffic, to enter the construction area, shall slow down gradually in advance of the location of the turnoff to give following public traffic an opportunity to slow down.
- i. When leaving a Work area and entering a roadway carrying public traffic, the Contractor's equipment, whether empty or loaded, shall in all cases yield to public traffic.
- j. Lanes, ramps and shoulders shall be closed in accordance with the details shown on the plans, and as provided in the Special Provisions.
- k. The Contractor shall notify the Engineer not less than 18 days and not more than 90 days prior to the anticipated start of an operation that will change the vertical or horizontal clearance available to public traffic (including shoulders).
- l. Pedestrian openings through falsework shall be paved or provided with full width continuous wood walks and shall be kept clear. Pedestrians shall be protected from falling objects and curing water for concrete. Overhead protection for pedestrians shall extend not less than 4 feet beyond the edge of the bridge deck. All pedestrian openings through falsework shall be illuminated.
- m. When vertical clearance is temporarily reduced to 15 feet, or less, low clearance warning signs shall be placed in accordance with Chapter 2 of the MUTCD, and as directed by the Engineer. Signs shall conform to the dimensions, color, and legend requirements of the MUTCD, the MUTCD California Supplement, and these specifications except that the signs shall have black letters and numbers on an orange retroreflective background. W12-2P signs shall be illuminated so that the signs are clearly visible.

- n. No material or equipment shall be stored where it will interfere with the free and safe passage of public traffic, and at the end of each day's Work and at other times when construction operations are suspended for any reason, the Contractor shall remove all equipment and other obstructions from that portion of the roadway open for use by public traffic.
- o. Temporary facilities which the Contractor uses to perform the Work shall not be installed or placed where they will interfere with the free and safe passage of public traffic.
- p. Temporary facilities which could be a hazard to public safety if improperly designed shall comply with design requirements specified in the Agreement for those facilities or, if none are specified, with standard design criteria or codes appropriate for the facility involved. Working drawings and design calculations for the temporary facilities shall be prepared and signed by an engineer who is registered as a Civil Engineer in the State of California and shall be submitted to the Engineer for approval. The submittals shall designate thereon the standard design criteria or codes used. Installation of the temporary facilities shall not start until the Engineer has reviewed and approved the drawings.
- q. Should the Contractor appear to be neglectful or negligent in furnishing warning devices and taking protective measures as above provided, the Engineer may direct attention to the existence of a hazard and the necessary warning devices shall be furnished and installed and protective measures taken by the Contractor at the Contractor's expense. Should the Engineer point out the inadequacy of warning devices and protective measures, that action on the part of the Engineer shall not relieve the Contractor from responsibility for public safety or abrogate the obligation to furnish and pay for these devices and measures.
- r. Provision for the payment for signs, lights, flares, temporary railing (Type K), barricades, and other facilities as provided in Section 6-1.16, "Public Convenience," or by contract item, shall in nowise relieve the Contractor from the responsibility as provided in this Section 6-1.17.
- s. Except as otherwise provided in this Section 6-1.17 or in the Special Provisions, full compensation for conforming to all of the provisions in this Section 6-1.17 shall be considered as included in the prices paid for the various contract items of Work and no additional compensation will be allowed therefor.

**6-1.18 Preservation of Property.**

- a. Roadside trees, shrubs and other plants that are not to be removed, and pole lines, fences, signs, markers and monuments, buildings and structures, conduits, pipelines under or above ground, sewer and water lines, all highway facilities and any other improvements or facilities within or adjacent to the highway shall be protected from injury or damage, and if ordered by the Engineer, the Contractor shall provide and install suitable safeguards, approved by the Engineer, to protect the objects from injury or damage. If the objects are injured or damaged by reason of the Contractor's operations, the objects shall be replaced or restored at the Contractor's expense. The facilities shall be replaced or restored to a condition as good as when the Contractor entered upon the Work, or as good as required by the Agreement, if any of

the objects are a part of the Work. The Engineer may make or cause to be made those temporary repairs that are necessary to restore to service any damaged highway facility. The cost of the repairs shall be borne by the Contractor and may be deducted from any moneys due or to become due to the Contractor under the Contract.

- b. The fact that any underground facility is not shown upon the Project Plans shall not relieve the Contractor of the responsibility under Section 4-1.05, "Utility and Non-Highway Facilities." It shall be the Contractor's responsibility, pursuant thereto, to ascertain the location of those underground improvements or facilities which may be subject to damage by reason of the Contractor's operations.
- c. Full compensation for furnishing all labor, materials, tools, equipment, and incidentals, and for doing all the Work involved in protecting or repairing property as specified in this Section 6-1.18, shall be considered as included in the prices paid for the various contract items of Work and no additional compensation will be allowed therefor.

**6-1.19 Sound Control Requirements.** The Contractor shall comply with all local sound control and noise level rules, regulations and ordinances which apply to any Work performed pursuant to the Agreement. Each internal combustion engine, used for any purpose on the job or related to the job, shall be equipped with a muffler of a type recommended by the manufacturer. No internal combustion engine shall be operated on the project without the muffler.

**6-1.20 Disposal of Material Outside The Right Of Way.**

- a. If the Contractor elects to dispose of materials at locations other than those where arrangements have been made by the City, or, if material is to be disposed of and the City has not made arrangements for disposal of the material, the Contractor shall make arrangements for disposing of the materials outside the highway right of way and shall pay all costs involved. Arrangements shall include, but not be limited to, entering into agreements with property owners and obtaining necessary permits, licenses and environmental clearances. Before disposing of any material outside the highway right of way, the Contractor shall furnish to the Engineer satisfactory evidence that the Contractor has entered into agreements with the property owners of the site involved and has obtained the permits, licenses and clearances.
- b. When any material is to be disposed of outside the highway right of way, and the City has not made arrangements for disposal of the material, the Contractor shall first obtain written authorization from the property owner on whose property the disposal is to be made and the Contractor shall file with the Engineer the authorization or a certified copy thereof together with a written release from the property owner absolving the City from any and all responsibility in connection with the disposal of material on the property. Before any material is disposed of on the property, the Contractor shall obtain written permission from the Engineer to dispose of the material at the location designated in the authorization. When material is disposed of as above provided and the disposal location is visible from a highway, the Contractor shall dispose of the material in a neat and uniform manner to the satisfaction of the Engineer.

- c. Where the City has made arrangements with owners of land in the vicinity of a project for the disposal of materials on an owner's property, the arrangements are made solely for the purpose of providing all bidders an equal opportunity to dispose of the materials on the property. Bidders or Contractors may, upon written request, inspect the documents evidencing the arrangements between property owners and the City. The Contractor may, if the Contractor so elects, exercise any rights that have been obtained, which may be exercised by a Contractor under the arrangements, subject to and upon the conditions hereinafter set forth.
- d. Such arrangements are not a part of the Agreement and it is expressly understood and agreed that the City assumes no responsibility to the Contractor whatsoever in respect to the arrangements made with the property owner to dispose of materials thereon and that the Contractor shall assume all risks in connection with the use of the property, the terms upon which the use shall be made, and there is no warranty or guaranty, either express or implied, as to the quantity or types of materials that can be disposed of on the property.
- e. In those instances in which the City has compiled "Materials Information" as referred to in Section 3, "Examination of Plans, Specifications, Contract, and Site of Work," of Instructions to Bidders, the compilation will include the documents setting forth the arrangement made with some of the property owners for the disposal of material on those owners' properties. The inclusion of the documents therein shall not in any respect operate as a waiver of any of the provisions in this Section 6-1.20 concerning the documents.
- f. The Contractor is cautioned to make such independent investigation and examination as the Contractor deems necessary to be satisfied as to the quantity and types of materials which may be disposed of on the property and the rights, duties and obligations acquired or undertaken under the arrangement with the property owner.
- g. Notwithstanding that the Contractor may elect to dispose of materials on any such property owner's property, no material may be disposed of on that property unless the Contractor has first either:
  - 1. Executed a document that will guarantee to hold the owner harmless from all claims for injury to persons or damage to property resulting from the Contractor's operations on the property owner's premises and also agreed to conform to all other provisions set forth in the arrangement made between the City and the property owner. The document will be prepared by the Engineer for execution by the Contractor, or
  - 2. Entered into an agreement with the property owner of the disposal site on any terms mutually agreeable to the property owner and the Contractor; provided that the Contractor shall furnish to the Engineer a release, in a form satisfactory to the Engineer, executed by the property owner, relieving the City of any and all obligations under the City's arrangement with the owner.
- h. If the Contractor elects to dispose of material under Section 6-1.20g.1, the use of the site shall be subject to the terms, conditions and limitations of the arrangement made between the property owner and the City and the Contractor shall pay those charges that are provided for in

the arrangement made by the City with the property owner, and deductions will be made from any moneys due or that may become due the Contractor under the contract sufficient to cover the charges for the material disposed of.

- i. If the Contractor elects to dispose of material under Section 6-1.20g.2, the Contractor shall pay those charges that are provided for in the agreement between the property owner and the Contractor and deductions will not be made from any moneys due or that may become due the Contractor under the contract to cover the charges.
- j. The Engineer may require the Contractor to submit written evidence that the property owner of the disposal site is satisfied that the Contractor has satisfactorily complied with the provisions of either: (1) the arrangement between the City and the property owner, or (2), the agreement between the property owner and the Contractor, as the case may be.
- k. Full compensation for all costs involved in disposing of materials as specified in this Section 6-1.20, including all costs of hauling, shall be considered as included in the price paid for the contract item of Work involving the materials and no additional compensation will be allowed therefor.

**6.1-21 Assignment of Unfair Business Practice Claims.** In accordance with California Public Contract Code Section 7103.5, the Contractor and any subcontractors offer and agree to assign to the City all right, title, and interest in and to all causes of action the Contractor or any subcontractors may have under Section 4 of the Clayton Act (15 U.S.C. § 15) or under the Cartwright Act (Chapter 2 (commencing with § 16700) of Part 2 of Division 7 of the Business and Professions Code), arising from purchases of goods, services or materials pursuant to this Contract. This assignment shall be made and become effective at the time the City tenders final payment to the Contractor, without further acknowledgement by the parties.

**6-1.22 Notice of Potential Claim**

- a. If for any reason the Contractor deems that additional compensation is due for Work or materials not clearly provided for in the Agreement, Project Plans or Technical Specifications or previously authorized extra work, a Notice of Potential Claim shall be made. The Contractor shall give the Engineer a written Notice of Potential Claim concerning such additional compensation before Work begins on the items on which the claim is based. The notice shall set forth the reasons for which the Contractor believes additional compensation will or may be due and the nature of the costs involved. Any Notice of Potential Claim submitted to the City by the Contractor shall have attached the following certification executed by an officer of the Contractor:

I, \_\_\_\_\_, being the \_\_\_\_\_ of \_\_\_\_\_ (Contractor), declare under penalty of perjury under the laws of the State of California, and do personally certify and attest that: I have thoroughly reviewed the attached claim and know its contents, and said claim is made in good faith; that it is supported by truthful and accurate data; that the amount requested accurately reflects the contract adjustment for which the Contractor believes the City is liable; and further, that I am familiar with California Penal Code section 72 and California

Government Code section 12650, et seq., pertaining to false claims, and further know and understand that submission or certification of a false claim may lead to fines, imprisonment, or other severe legal consequences.

- b. The Contractor shall afford the Engineer every opportunity and facility for keeping records of actual cost of the work. The Contractor shall keep records of the disputed work in accordance with Section 3-1.17, Change Order Pricing.
- c. If such notification is not given or the Engineer is not afforded proper opportunity by the Contractor for keeping strict account of actual cost as required, then the Contractor hereby agrees to waive any claim for such additional compensation. Such notice by the Contractor and the fact that the Engineer has kept account of the cost of the Work shall not in any way be construed as proving or substantiating the validity of the claim. When the Work on the which the claim for additional compensation is based has been completed, the Contractor shall within 10 calendar days of completion submit the Contractor's written claim to the Engineer, who will present it to the City for consideration in accordance with the Agreement, including, but not limited to Section 9-1.03 of the General Provisions and applicable law.
- d. Any claim for overhead type expense or costs, in addition to being certified as stated above, shall be supported by an audit report of an independent Certified Public Accountant. Any claim for overhead shall also be subject to audit by the City at its discretion.
- e. Any costs or expenses incurred by the City in reviewing or auditing any claims that are not supported by the Contractor's cost accounting or other records shall be deemed to be damages incurred by the City within the meaning of the California False Claims Act.

**SECTION 7  
MEASUREMENT AND PAYMENT**

**7-1.01 F.O.B.** All shipments must be F.O.B. destination to the Work site and/or other sites indicated in the Contract Documents. The Contract Price is all-inclusive (including sales tax). There shall be no additional compensation paid for containers, packing, unpacking, drayage or insurance. The Contract Price includes full compensation for all taxes which the Contractor is required to pay, whether imposed by Federal, State or local government, including, without being limited to, Federal excise tax. No tax exemption certificate nor any document designed to exempt the Contractor from payment of any tax will be furnished to the Contractor by the City, as to any tax on labor, services, materials, transportation, or any other items furnished pursuant to this Agreement.

**7-1.02 Payment.**

- a. On or about the first day of each calendar month the Contractor will submit to the Engineer a verified application for payment and schedule of values supported by a statement showing all materials actually installed during the preceding month and the cost of labor actually expended in the performance of the Work. Unless otherwise provided in the Contract Documents, no allowances or payments will be made for material or equipment not placed at the Work site. Each invoice shall contain the following certification executed by a duly authorized officer of the Contractor:

I, \_\_\_\_\_, being the \_\_\_\_\_ of \_\_\_\_\_ (Contractor), declare under penalty of perjury under the laws of the State of California, and do personally certify and attest that: I have thoroughly reviewed the attached application for payment and know its contents, and said application is made in good faith; that it is supported by truthful and accurate data; that the amount requested accurately reflects the costs incurred during the period covered by this application; and further, that I am familiar with California Penal Code section 72 and California Government Code section 12650, et seq., pertaining to false claims, and further know and understand that submission or certification of a false claim may lead to fines, imprisonment, or other severe legal consequences.

- b. To be eligible for payment, the Contractor's applications for payment must include certified payroll reports prepared in accordance with California Labor Code Section 1776 and the Agreement for each employee of the Contractor and any subcontractors engaged in the performance of the Work during the preceding months. Applications for payment will not be processed without certified payroll reports.
- c. In accordance with California Public Contract Code Section 20104.50, the City will review applications for payment as soon as practicable after receipt. Any application or part of an application that is determined to be improper will be returned to the Contractor as soon as practicable, but no later than seven days after receipt by the City, along with a written description of the reasons why the application is improper. The Contractor's failure to submit a schedule in the time specified in Section 3-1.10 of the General Provisions or its submission of a



schedule to which the City has taken any uncorrected exception, shall serve as a basis for returning an application for payment in its entirety.

- d. Unless the Contractor has elected to post securities in lieu of retention in accordance with California Public Contract Code Section 22300 and the Agreement, and the Contractor and the City have executed an escrow agreement in accordance with Public Contract Code Section 22300 and the Agreement, the City will make progress payments to the Contractor in accordance with applicable law in the amount of ninety (90) percent of the value of the labor actually performed and the material incorporated in the Work as specified in Contractor's verified application for payment upon approval by the City's authorized representative(s). Payment of progress payments will not be construed as acceptance of the Work performed. If the Contractor has elected to post securities in lieu of retention in accordance with Public Contract Code Section 22300 and the Agreement and the Contractor and the City have executed an escrow agreement in accordance with Public Contract Code Section 22300 and the Agreement, the City will make payments to the Contractor or the Contractor's escrow agent in accordance with such escrow agreement.
- e. The City will pay the Contractor's final invoice in accordance with applicable law and this Section 7 of the General Provisions following acceptance of the Work provided that:
  - 1. The Contractor has furnished evidence satisfactory to the City that all claims for labor and material have been paid, or the time for filing valid stop notices has passed and no stop notices have been filed, or all stop notices filed have been released by valid release or release bond acceptable to the City.
  - 2. No claim has been presented to the City by any person based upon any acts or omissions of the Contractor or any subcontractor engaged in the performance of the Work.
  - 3. No other claim or dispute exists under the Agreement or applicable law concerning payment of the Contractor's final invoice and/or release of the Agreement retention.
  - 4. The Contractor has filed with the City the Maintenance Bond provided in the Contract Documents with duly notarized signatures of an authorized representative of the Contractor and an attorney-in-fact of an admitted surety insurer acceptable to the City and such Maintenance Bond binds the Contractor as Principal and the Surety in accordance with its terms in the amount of 10% of the final Contract Price.
- f. In accordance with California Public Contract Code Section 20104.50, if the City fails to make a progress payment within thirty (30) days of receipt of an undisputed, properly submitted application for payment, the City will pay the Contractor interest equivalent to the legal rate set forth in subdivision (a) of California Code of Civil Procedure Section 685.010. The number of days available to the City to make a payment without incurring an interest obligation pursuant to this provision and California Public Contract Code Section 20104.50 will be reduced by the number of days, if any, by which the City has delayed return of an application for payment beyond the seven day return requirement set forth in Section 7-1.02.

**7-1.03 Non-Allowable Direct Charges.** The following costs are not allowable direct charges under the Agreement. The following costs may only be paid under the Agreement, if at all, as part of any allowance for Contractor overhead and/or profit established under the Agreement.

- a. Labor costs in excess of applicable prevailing wages pursuant to the Agreement and applicable law, liability and workers compensation insurance, social security, retirement and unemployment insurance and other employee compensation and benefits pursuant to bona fide compensation plans in effect at the time specified for the opening of Project bids for Contractor and subcontractor employees engaged in the performance of the Work. However, in no event will allowable direct labor charges under the Agreement include employee bonuses, employee vehicles or vehicle allowances, employee telephones or telephone allowances, or employee housing or housing allowances, whether or not such benefits are part of a bona fide compensation plan in effect at the time specified for the opening of Project bids.
- b. Superintendent labor and clerical labor.
- c. Bond premiums.
- d. Insurance in excess of that required under Section 6-1.08 of the General Provisions.
- e. Utility costs.
- f. Work Site office expenses.
- g. Home office expenses.

**7-1.04 Retention.** The City or its agent may, in accordance with the Contract Documents and applicable law, withhold any payment of monies due or that may become due the Contractor because of:

- a. Defective work not remedied or uncompleted work.
- b. Claims filed or reasonable evidence indicating probable filing of claims.
- c. Failure to properly pay subcontractors or to pay for material or labor.
- d. Reasonable doubt that the Work can be completed for the balance then unpaid.
- e. Damage to another contractor.
- f. Damage to the City.
- g. Damage to a third party.
- h. Delay in the progress of the Work, which, in the City's judgment, is due to the failure of the Contractor to properly expedite the Work.
- i. Liquidated damages or other charges that apply to the Contractor under the Agreement.
- j. Any other lawful basis for withholding payment under the Contract.

**7-1.05 Securities in Lieu of Retention.**

- a. In accordance with Public Contract Code Section 22300, except where federal regulations or polices do not permit substitution of securities, the Contractor may substitute securities for any moneys withheld by the City to ensure performance of the Work. At the Contractor's request and expense, securities equivalent to the amount withheld will be

deposited with the City, or with a state or federally chartered bank in California as the escrow agent, who will then pay those moneys to the Contractor under the terms of an Escrow for Security Deposit agreement. The Escrow for Security Deposit agreement is provided in the Contract Documents. Upon satisfactory completion of the Work, the securities will be returned to the Contractor.

- b. Alternatively, at the Contractor's request and expense, the City will pay retentions earned directly to the escrow agent. At the Contractor's expense, the Contractor may direct investment of the payments into securities. Upon satisfactory completion of the Work, the Contractor will receive from the escrow agent all securities, interest, and payments received by the escrow agent from the City pursuant to this provision and the terms of the Escrow for Security Deposit agreement. The Contractor will, within 20 days of receipt of payment, pay to each subcontractor the respective amount of interest earned, less costs of retention withheld from each Subcontractor, on monies withheld to ensure the Contractor's performance of the Work.
- c. Securities eligible for investment in accordance with this provision include those listed in Government Code Section 16430, bank or savings and loan certificates of deposit, interest bearing demand deposit accounts, standby letters of credit, or any other security mutually agreed to by the Contractor and the City.
- d. The Contractor will be the beneficial owner of any securities substituted for moneys withheld and will receive any interest thereon.

**SECTION 8  
PROJECT ACCEPTANCE AND CLOSEOUT**

**8-1.01 Occupancy.** The City reserves the right to occupy or use any part or parts or the entirety of the Work before the Work is fully performed. Subject to applicable law, exercising this right will in no way constitute acceptance of any part of the Work so occupied or used or acceptance of the entire Work, nor will such occupancy or use in any way affect the times when payments will become due the Contractor, nor will such occupancy or use in any way prejudice the City's rights under the Agreement, any Agreement bonds, or at law or equity. Occupancy or use shall not waive the City's rights to assess liquidated damages in accordance with Section 5 after the date of such occupancy or use.

**8-1.02 Work Completion and Final Inspection.** When the Contractor considers the Work is completed, the Contractor will submit written certification to the Engineer specifying that: the Contract Documents have been reviewed; the Work has been inspected for compliance with the Contract Documents; the Work has been completed in accordance with the Contract Documents; and that equipment and systems have been tested in the presence of the City's representative and are operational. The City and/or the City's authorized representatives will make an inspection to verify that the Work is complete and will notify the Contractor in writing of any incomplete or deficient Work. The Contractor will take immediate steps to remedy the stated deficiencies and give notice of correction to the Engineer. Upon receiving a notice of correction, the City or the City's authorized representatives will re-inspect the Work. The Contractor must correct all punch list items within 15 working days after the issuance of the punch list. Before acceptance of the Work the Contractor must submit: one set of the Project Record Drawings (As-Builts), and any equipment operating and maintenance instructions and data, warranties.

**8-1.03 Work Acceptance.**

- a. All finished Work will be subject to inspection and acceptance or rejection by the City, the Engineer, and the Designer or other government agencies having jurisdiction over the Work. Final acceptance of the Work will be at the discretion of the City.
- b. The City will accept the Work in writing only when the Work has been completed to the City's reasonable satisfaction. Progress payments will in no way be construed as acceptance of any part of the Work
- c. In evaluating the Work, no allowance will be made for deviations from the Technical Specifications, Project Plans or other Contract Documents unless already approved in writing in accordance with the requirements of Section 3, above.
- d. The fact that the Work and materials have been inspected from time to time and that progress payments have been made does not relieve the Contractor of the responsibility of

replacing and making good any defective or omitted work or materials in accordance with the requirements of the Contract Documents.

**SECTION 9  
REMEDIES AND DISPUTES**

**9-1.01 Failure to Correct Work.** Within ten (10) working days of receiving written notice from the City describing Work that is defective or that is otherwise not in accordance with the requirements of the Agreement and/or applicable law and directing that such Work be corrected, the Contractor and/or the Contractor's sureties must give the City written notice of the intent of the Contractor and/or the Contractor's sureties to correct such Work and commence correction of such Work in accordance with the City's notice and the Agreement. If the Contractor and/or the Contractor's sureties do not give the City written notice of intent to correct such Work and commence correction of such Work within ten (10) working days of receipt of the City's notice, then the City may correct such work and/or have such work corrected for the account and at the expense of the Contractor and/or its sureties, and the Contractor and/or its sureties will be liable to the City for any resulting excess cost. The City may, in addition to all other remedies that the City may have under the Agreement and at law or equity, deduct any such excess cost of completing the Work from amounts that are due or that may become due the Contractor.

**9-1.02 Termination.**

- a. In accordance with California Public Contract Code Section 7105, in addition to all other available remedies that the City may have under the Agreement, and at law or equity, the City may terminate the Agreement:
  - 1. If the Contractor or any of its subcontractors engaged in the performance of the Work fails to timely perform the Work and/or any of the Contractor's material obligations under the Contract Documents, including but not limited to submission of an acceptable schedule, that have accrued except for those due to reasons beyond the control of the Contractor pursuant to the Contract Documents.
  - 2. If the Contractor is adjudged bankrupt, or if it should make a general assignment for the benefit of creditors, or if a receiver should be appointed on account of its creditors.
  - 3. If the Contractor or any of the subcontractors engaged in the performance of the Work persistently or repeatedly refuses or fails to supply enough properly skilled workmen or proper materials for the timely completion of the Work.
  - 4. If the Contractor fails to make prompt payment to subcontractors engaged in the performance of the Work or for material or labor used in the performance of the Work in accordance with the Contract Documents and applicable law.
  - 5. If the Contractor or any subcontractors engaged in the performance of the Work persistently disregards laws or ordinances applicable to the performance of the Work, or the instructions of the City, the Engineer, the Designer, or other authorized representatives of the City.

6. For any reason or for no reason, at the City's sole discretion.
  
- b. If the City intends to terminate the Contractor's control of the Work for any of the reasons specified in Section 9-1.02(a) 1 through 5, above, the City will immediately serve written notice to the Contractor and its sureties in accordance with the Contract Documents. Notice of the City's intent to terminate the Agreement will be given by registered or certified mail and specify the grounds for termination, the required cure and the time by which the cure must be effected. Upon receipt of notice of the City's intent to terminate the Agreement for any of the reasons specified in Section 9-1.02(a) 1 through 5, the Contractor will have ten (10) days from receipt of the notice or a longer time specified in the notice to cure its default. If the Contractor does not effect the required cure by the time specified in the notice, the City will issue a written notice of termination to the Contractor and its sureties by registered or certified mail. The notice of termination will specify: that upon receipt of the notice the Contractor's right to perform or complete the Work, including on behalf of the Contractor's sureties, is terminated; that the Contractor's sureties will have the right to take over and complete the Work and perform all of the Contractor's remaining obligations that have accrued under the Agreement; and that if the Contractor's sureties do not both give the City written notice of their intention to take over and perform the Agreement and commence completion of the Work and performance of all of the Contractor's remaining obligations that have accrued under the Agreement within ten (10) days after receipt of notice of termination that the City may declare the Contractor's sureties in default and take over the completion of the Work or have the Work completed for the account and at the expense of the Contractor and its sureties, and the Contractor and its sureties will be liable to the City for any resulting excess cost. The City may, in addition to all other available remedies that the City may have under the Contract Documents and at law or equity, deduct any such excess cost of completing the Work from amounts that are due or that may become due the Contractor.
  
- c. Upon termination of the Contractor's control of the Work for any of the reasons specified in Section 9-1.02(a) 1 through 5, the Contractor will, if so directed by the City, immediately remove from the Work site any and all materials and personal property belonging to the Contractor which have not been incorporated in the Work and the Contractor and its sureties will be liable upon their bond for all damages caused the City by reason of the Contractor's failure to complete the Work.
  
- d. Upon termination of the Contractor's control of the Work for any of the reasons specified in Section 9-1.02(a) 1 through 5, above, the City reserves the right to refuse tender of the Contractor by any surety to complete the Work.
  
- e. If the City completes or has completed any portion of, or the whole of the Work, following termination of the Contractor's control of the Work for any of the reasons specified in Section 9-1.02(a) 1 through 5, above, the City will neither be liable for nor required to account to the Contractor or the Contractor's sureties in any way for the time within which, or the manner in which such Work is performed, or for any changes made in such Work or for the money expended in satisfying claims and/or suits and/or other obligations in connection with completing the Work. If, following termination of the Contractor's control of the Work for any of the reasons specified in Section 9-1.02(a) 1 through 5, above, the

unpaid balance of the Contract Price exceeds the expense of completing the Work, including compensation for additional legal, managerial and administrative services and all other amounts due for the completion of the Work and/or satisfaction of claims of the City and/or others arising out of the Agreement and any other charges that apply to the Contractor under the Agreement, the difference will be paid to the Contractor. If such expenses of completing the Work exceed the unpaid balance of the Contract Price, the Contractor or its sureties will pay the difference to the City.

- f. If the Agreement or Contractor's control of the Work is terminated for any reason, no allowances or compensation will be granted for the loss of any anticipated profit by the Contractor.
  
- g. In accordance with California Government Code Section 4410, in the event a national emergency occurs, and public work being performed by contract is stopped, directly or indirectly, because of the freezing or diversion of materials, equipment or labor, as the result of an order or a proclamation of the President of the United States, or of an order of any federal authority, and the circumstances or conditions are such that it is impracticable within a reasonable time to proceed with a substantial portion of the Work, then the City and the Contractor may, by written agreement, terminate the Agreement. In accordance with California Government Code Section 4411, such an agreement will include the terms and conditions of the termination of the Contract and provision for the payment of compensation or money, if any, which either party will pay to the other or any other person, under the facts and circumstances in the case. Compensation to the Contractor will be determined on the basis of the reasonable value of the Work done, including preparatory Work. As an exception to the foregoing, in the case of any fully completed separate item or portion of the Work for which there is a separate contract price, the Contract Price shall control. The parties may in any other case adopt the Contract Price as the reasonable value of the Work or any portion of the Work done.

**9-1.03 Disputes.**

**9-1.03.01 Definitions**

For purposes of this section, the following Definitions shall apply:

- A. "Disputed Work" - Work that Contractor contends is outside the scope of the Contract Documents or in violation of the terms of the Contract Documents, resulting from any decision, determination, order, direction, instruction, notice, action, or omission of the City being otherwise incorrect or improper. Disputed Work includes any claims or potential claims regarding loss of productivity, delays, impacts, arising or occurring during the Work, that Contractor may assert resulted from acts or omissions of the City that were outside the requirements of the Contract Documents.
- B. "Good Faith Negotiations" means the successive, tiered negotiations of Disputed Work, each with increasing levels of documentation and substantiation, starting at the Project level and escalating to the Authorized Representative level, then the Executive level, prior to Contractor filing a Final Claim.



- C. “Claim” or “statutory claim” is defined in Public Contract Code section 9104, and means “a separate demand by the contractor sent by registered mail or certified mail with return receipt requested, for one or more of the following:
  - a. A time extension, including, without limitation, for relief from damages or penalties for delay assessed by a public entity under a public works contract.
  - b. Payment by the City of money or damages arising from work done by, or on behalf of, the Contractor pursuant to the contract for a public work and payment for which is not otherwise expressly provided or to which the claimant is not otherwise entitled.
  - c. Payment of an amount that is disputed by the public entity.
  
- D. Final Claim means the certified Final Claim prepared and submitted by Contractor if Good Faith Negotiations fail to result in settlement of the claim.

**9-1.03.02 Requirements of Good Faith Negotiations**

**A. Introduction**

- a. At any time during the Good Faith Negotiations defined in this Section, Contractor may serve a statutory claim pursuant to Public Contract Code section 9204. Upon receipt of a claim pursuant to that section, the City will conduct a reasonable review of the claim and, within a period not to exceed 45 days, shall provide Contractor a written statement identifying what portion of the claim is disputed and what portion is undisputed. Upon receipt of a claim, the City and Contractor may, by mutual agreement, extend the time period provided in this subdivision. Contractor shall furnish reasonable documentation to support the claim.
- b. Notwithstanding the service of a statutory claim, Contractor must comply with the Good Faith Negotiations procedures defined in this Section. Failure to so comply shall operate as a waiver of Contractor’s claims.

**B. Notification of Disputed Work Required.**

- a. Contractor shall promptly, and before commencing Disputed Work, notify The City’s Authorized Representative in writing before proceeding with such Work. Contractor’s written notification shall state the objection and the basis of the objection (“Disputed Work”).
- b. If Contractor proceeds with the Disputed Work without complying with the written notice requirement, Contractor will be deemed to have assented that the Work is within the Contract’s requirements, and shall waive its rights to further right to a protest or Claim.
- c. Contractor shall provide written notice of Disputed Work concurrently with Contractor’s incurring any costs it may claim are the responsibility of the City.

**C. Contemporaneous Records**

- a. Beginning with the first day on which any Disputed Work is performed, and each following Day, Contractor shall maintain detailed hourly records of labor, construction equipment, and services, and itemized records of materials and equipment used each Day in the performance of the Disputed Work. Such records must be of a form acceptable to the City, shall be signed by Contractor, copies provided to the City daily, and are subject to verification by the City.

**D. Initial Substantiation (within ten (10) Days after Contractor’s first knowledge of the Disputed Work.)**

- a. Within ten (10) Days after Contractor’s first knowledge of the Disputed Work, Contractor shall provide the City with a written statement of dispute (“Dispute”) that includes a preliminary cost proposal for the Disputed Work stating clearly and in detail its objection and reasons for contending the Disputed Work is outside or in breach of the requirements of Contract Documents. The preliminary cost proposal must provide a good faith preliminary estimate of the labor (workers, crews), equipment and/or materials involved, and a corresponding good faith preliminary estimate of cost. It is the responsibility of Contractor to substantiate that the Disputed Work is in fact a change from the base scope of Work.
- b. The written Dispute must identify the subcontractors, vendors, suppliers affected, if any, sufficient for the City to visit the Site to inspect the work and/or conduct a telephonic interview of the persons involved, and/or to photograph the work in question. Contractor shall provide by email digital photographs of the Disputed Work and provide City with contact information for all involved subcontractors and/or suppliers of any tier to facilitate prompt “in person” review at the next job site meeting.

**E. First Negotiation: At Project Level. (No later than twenty-one (21) Days after Contractor’s first knowledge of the Dispute).**

- a. The written notice and preliminary cost proposal for Disputed Work must be placed, by Contractor, as either a specific discussion item on the Agenda for the next weekly meeting, or to occur immediately before or following the weekly meeting. Both Owner and Contractor shall then make a good-faith effort to review the Disputed Work. It is expected that discussions will occur no later than twenty-one (21) Days after Contractor’s first knowledge of the Dispute.

**F. Updated Dispute Substantiation (no later than thirty (30) days of Contractor’s first knowledge of Disputed Work).**

- a. In the event negotiations at the next job site meeting do not result in resolution of the Dispute, and in any event no later than thirty (30) days of Contractor’s first knowledge of Disputed Work, Contractor must update its Dispute (“Updated Dispute”) to meet the following requirements.
- b. Contractor shall submit the Updated Dispute documentation in the following format:
  - 1. Introduction and Issue Identification
  - 2. Background
  - 3. Chronology
  - 4. Contractor's Position (Reason for County's potential liability)
  - 5. Supporting documentation of merit
  - 6. Supporting documentation of damages
  - 7. Schedules (if appropriate)
  - 8. Productivity exhibits (if appropriate)

- c. Contractor shall explain, cite by reference to Contract Documents and documents from the Project record and/or submit photocopies of documents supporting the merit of its position.
- d. Contractor shall explain, cite by reference to, and/or submit photocopies of documents supporting damages. Contractor must submit substantial supporting documentation with this Updated Dispute documentation; categories and amounts not identified and justified, will be deemed waived. Contractor may not assert, subsequently, new or different categories or amounts of damages.

**G. Second Negotiation: At Project Representative Level. (No later than forty-five (45) Days after Contractor’s first knowledge of the Dispute).**

- a. If City and Contractor do not resolve the Disputed Work at their first meeting, then Contractor shall submit its Updated Dispute and shall calendar the matter for discussion with Contractor’s Representative and Owner’s Representative to occur within twenty (20) Days of the weekly meeting and no later than forty-five (45) Days after Contractor’s first knowledge of the Dispute.
- b. The City’s Representative will consider the information provided by Contractor and from City’s resources, and will provide a decision in writing. If Contractor disputes the written decision, then Contractor’s remedy is to file a Notice of Potential Claim meeting the requirements below.
- c. If for any reason Owner should fail to act or provide a decision on a Dispute or Updated Dispute, all within the required forty-five (45) Days, then the Dispute and Updated Dispute shall be deemed denied by Owner’s Representative on the forty-sixth (46th) Day.

**H. Notice of Potential Claim (no later than fifty-five (55) Days after Contractor’s first knowledge of the Dispute).**

- a. If, after receiving City’s Representative’s decision, Contractor disagrees with it or still considers the Disputed Work required of it to be outside the requirements of the Contract Documents, then Contractor shall so notify City in writing within ten (10) Days after receiving the decision by submitting a Notice of Potential Claim (“NOPC”) stating that it will issue a formal claim.

**I. Third Negotiation: Meeting of Executives.**

- a. Upon receipt of Contractor’s NOPC, Contractor and City shall negotiate the claim between and among the Contractor’s Representative and Owner’s Representative. Negotiations in response to the NOPC will not extend the time to file the Formal Claim.

**J. FINAL CLAIM AND CERTIFICATION (Within seventy-five (75) Days of Contractor’s first knowledge of a Dispute, or within thirty (30) Days of Owner’s written decision on Contractor’s Dispute and Updated Dispute.)**

- a. Within seventy-five (75) Days of Contractor’s first knowledge of a Dispute, or within thirty (30) Days of City’s written decision on Contractor’s Dispute and Updated Dispute, Contractor shall file with City its formal claim(s), in the form specified in this Section. For each NOPC Contractor intends to pursue as a formal claim, Contractor shall include all arguments, justification, cost or estimates, schedule analysis, and

detailed documentation supporting Contractor's position. Contractor is encouraged to designate its Final Claim and Certification as its statutory claim.

- b. Claim Documentation. Contractor's Claim documentation shall conform to generally accepted auditing standards (GAAS). Contractor shall submit the Claim in the following format:
  - 1. Introduction
  - 2. General Background Discussion
  - 3. Summary of Issues and Damages
  - 4. Index of Issues
  - 5. For Each Issue (Begin each issue on a new page)
    - a. Background
    - b. Chronology
    - c. Contractor's Position (Reason for County's potential liability)
    - d. Supporting Documentation of Merit
    - e. Supporting Documentation of Damages
    - f. Schedules (if appropriate)
    - g. Productivity exhibits (if appropriate)
- A. Contractor shall explain, cite by reference to, and/or submit photocopies of, documents supporting the merit of its position. Supporting documentation may include, but not be limited to, General Conditions, General Requirements, Technical Specifications, Drawings, correspondence, conference notes, Shop Drawings and other Submittals, Submittal Logs, survey books, inspection reports, delivery schedules, test reports, daily reports, subcontracts, fragmentary Critical Path method schedules, photographs, technical reports, Requests for Information, field instructions, and other related records necessary to support the merit of Contractor's position.
- B. Contractor shall explain, cite by reference to, and/or submit photocopies of, documents supporting damages. Supporting documentation may include, but not be limited to, any or all documents related to the preparation and submission of the Bid; Subcontractor, Supplier or vendor files and cost records; certified payroll reports, materials, equipment, and construction equipment and services costs; purchase orders; invoices; project as planned and as built costs; Subcontractor and Supplier payment documentation; quantity reports; other related records; general ledger and any other accounting materials necessary to support the Contractor's position.

**K. CLAIMS SHALL BE CALCULATED IN THE SAME MANNER AS CHANGE ORDERS PER SECTION 01 26 00 (CONTRACT MODIFICATION PROCEDURES). NO SPECIAL, INCIDENTAL OR CONSEQUENTIAL DAMAGES MAY BE CLAIMED, REQUESTED OR RECOVERED.**

**9-1.03.03 Subcontractor Claims**

- A. Contractor shall require each Subcontractor, sub-Subcontractor and supplier to comply with the claims procedure set forth in this Document 00 73 83 to provide Contractor with timely notice and documentation of all claims. Contractor shall present as its claims, all Subcontractor, sub-Subcontractor and supplier claims of any type, and prove them under the terms of the Contract Documents. Owner shall not be directly liable to any Subcontractor, any supplier, or

any other person or organization, or to any surety for or employee or agent of any of them, for damages or extra costs of any type arising out of or resulting from the Project.

**9-1.03.04 Written Decision and Action on Claims**

Time frames and procedures Decisions on statutory claims and formal claims follow the same procedures stated In Public Contract Code Section 9104:

- a. “Upon receipt of a claim pursuant to this section, the City shall conduct a reasonable review of the claim and, within a period not to exceed 45 days, shall provide the claimant a written statement identifying what portion of the claim is disputed and what portion is undisputed. Upon receipt of a claim, the City and Contractor may, by mutual agreement, extend the time period provided in this subdivision.
- b. If the City needs approval from its governing body to provide the claimant a written statement identifying the disputed portion and the undisputed portion of the claim, and the City does not meet within the 45 days or within the mutually agreed to extension of time following receipt of a claim sent by registered mail or certified mail, return receipt requested, the City shall have up to three days following the next duly publicly noticed meeting of the governing body after the 45-day period, or extension, expires to provide the claimant a written statement identifying the disputed portion and the undisputed portion.
- c. If the claimant disputes the City’s written response, or if the City fails to respond to a claim issued pursuant to this section within the time prescribed, the claimant may demand in writing an informal conference to meet and confer for settlement of the issues in dispute. Upon receipt of a demand in writing sent by registered mail or certified mail, return receipt requested, the City shall schedule a meet and confer conference within 30 days for settlement of the dispute.
- d. Within 10 business days following the conclusion of the meet and confer conference, if the claim or any portion of the claim remains in dispute, the City shall provide the claimant a written statement identifying the portion of the claim that remains in dispute and the portion that is undisputed. Any payment due on an undisputed portion of the claim shall be processed and made within 60 days after the public entity issues its written statement. Any disputed portion of the claim, as identified by the Contractor in writing, shall be submitted to nonbinding mediation, with the City and the claimant sharing the associated costs equally. The City and claimant shall mutually agree to a mediator within 10 business days after the disputed portion of the claim has been identified in writing. If the parties cannot agree upon a mediator, each party shall select a mediator and those mediators shall select a qualified neutral third party to mediate with regard to the disputed portion of the claim. Each party shall bear the fees and costs charged by its respective mediator in connection with the selection of the neutral mediator. If mediation is unsuccessful, the parts of the claim remaining in dispute shall be subject to applicable procedures outside this section.
- e. For purposes of this section, mediation includes any nonbinding process, such as neutral evaluation or a dispute review board, in which an independent third party or board assists the parties in dispute resolution through negotiation or by issuance of an evaluation. Any mediation utilized shall conform to the timeframes in this section.
- f. Unless otherwise agreed to by the City and the Contractor in writing, the mediation conducted pursuant to this section shall excuse any further obligation under Section 20104.4 of the Public Contract Code to mediate after litigation has been commenced.
- g. Failure by the City to respond to a claim from a Contractor within the time periods described in this subdivision or to otherwise meet the time requirements of this section shall result in the claim being deemed rejected in its entirety. A claim that is denied by reason of the City’s

failure to have responded to a claim, or its failure to otherwise meet the time requirements of this section, shall not constitute an adverse finding with regard to the merits of the claim or the responsibility or qualifications of the claimant.

- h. Amounts not paid in a timely manner as required by the negotiations required under Public Contract Code section 9204 shall bear interest at 7 percent per annum.”

**9-1.03.05 Claim Updates and Waiver**

- A. Claim Updates Required. If Disputed Work persists longer than a single calendar month, then for each quarter until the Disputed Work ceases, Contractor shall submit to City a document titled “Claim Update” that shall update and quantify all elements of the Claim as completely as possible. Contractor’s failure to submit a Claim Update or to quantify costs every quarter shall result in waiver of the Claim for that period. Claims or Claim Updates stating that damages, total damages (direct and indirect), schedule impact and/or any time extension will be determined at a later date shall not comply with this subparagraph and shall result in Contractor waiving its claim(s). Contractor shall also maintain a continuing “claims log” that shall list all outstanding claims and their value, and provide such log to Owner quarterly.
- B. Waiver. If the initially required notice of Dispute, Updated Dispute, Notice of Potential Claim and Final Claim, are not issued within the time period required herein, or if Contractor proceeds with the disputed Work without first having given the notice of the Disputed Work, Contractor shall be deemed to have waived its rights to further claim on the specific issue.

**9-1.03.06 Government Code Section 930.2**

- A. The procedures, negotiations, record keeping, documentation and Final Claim, if negotiation efforts prove unsuccessful, as required in this Section, are intended to constitute a mandatory administrative remedy and part One of a two-step claim procedure by agreement under California Government Code Section 930.2. Step One is compliance with the Good Faith Negotiations and Claim Requirements. Step Two is filing a Government Code Section 910 Claim in with the County following statutory procedures and identifying Claims submitted, negotiated and not settled.
- B. Should Contractor fail to timely comply with the procedures set forth in this Section, Contractor may have rights to apply for consideration of late claims following the procedures in Government Code Section 930.4. This Section defines the limits of authority of City’s representative to consider late claims and the basis therefore.

**9-1.03.07 Waiver and Substantial Compliance**

- A. If Contractor fails to comply with this Section as to any claim or Disputed Work, then Contractor shall waive its rights to such claim. All claim(s), Disputed Work items or issue(s) not raised in a timely notice, timely notice of potential claim and then timely claim submitted under this Section, may not be asserted in any subsequent arbitration (if subsequently agreed), litigation or legal action, and any award (or portion thereof), judgment or verdict contrary to this preclusion shall be vacated to the extent contrary.
- B. Contractor may request an extension of time to comply with the claims procedure herein, but must do so in advance of time periods expiring and City must give its approval in writing (which approval may be withheld in City’s discretion.) As to any other feature of the claim procedure herein (and its claims waiver feature), it may not be waived or altered absent a

written Change Order signed by both parties and accepted as to form by their legal counsel (for the City, the Office of the City Attorney.)

- C. The City, in its sole discretion, may consider Contractor’s substantial compliance with the required initial notice and written Dispute, provided Contractor demonstrates good faith and a manifest lack of prejudice to City from late written notice, for example, contemporaneous City/Contractor discussions and review of Disputed Work with full opportunity to investigate and verify costs and work performed. Under no circumstances may substantial compliance be considered when the required written notice is more than twenty-one (21) calendar days late.
- D. The City shall not be deemed to waive or alter any provision under this Section, if at City’s sole discretion; a claim is administered in a manner not in accord with this Section.
- E. Compliance with the foregoing shall not be a prerequisite to any Claim that is based solely on differences in measurement or errors of computations as to Contract quantities.

**9-1.03.08 Claims under \$375,000**

- A. The provision of Public Contract Code §20104 set seq. relating to the resolution of construction claims of three hundred seventy-five thousand dollars (\$375,000) or less which arise between a contractor and the City are hereby incorporated in this Contract and are *italicized* for ease of use.
- B. Documentation that is necessary to substantiate Claims submitted pursuant to this section must comply with the format requirements set forth in this Section.

- a. Claims for \$375,000 or below, as provided by Public Contract Code - §20104 (a)-(d), Application of article; provisions included in plans and specifications:

- (a) (1) *This article applies to all public works claims of three hundred seventy-five thousand dollars (\$375,000) or less which arise between a contractor and local agency.*

- (2) *This article shall not apply to any claims resulting from a contract between a contractor and a public agency when the public agency has elected to resolve any disputes pursuant to Article 7.1 (commencing with §10240) of Chapter 1 of Part 2.*

- (b) (1) *"Public work" means "public work contract" as defined in Section 1101 but does not include any work or improvement contracted for by the state or the Regents of the University of California.*

- (2) *“Claim” means a separate demand by the contractor for (A) a time extension, (B) payment of money or damages arising from work done by, or on behalf of, the contractor pursuant to the contract for a public work and payment of which is not otherwise expressly provided for or the claimant is not otherwise entitled to, or (C) an amount the payment of which is disputed by the local agency.*

- (c) The provisions of this article or a summary thereof shall be set forth in the plans or specifications for any work which may give rise to a claim under this article.

- (d) This article applies only to contracts entered into on or after January 1, 1991.

- C. Claims for \$375,000 or below, as provided by Public Contract Code - §20104.2 (a)-(f), Claims, requirements, tort claims excluded:

*For any claim subject to this article, the following requirements apply:*

- (a) *The claim shall be in writing and include the documents necessary to substantiate the claim. Claims must be filed on or before the date of Final Payment. Nothing in this subdivision is intended to extend the time limit or supersede notice requirements otherwise provided by contract for the filing of claims.*
- (b) (1) *For claims of less than fifty thousand dollars (\$50,000), the local agency shall respond in writing to any written claim within 45 days of receipt of the claim, or may request, in writing, within 30 days of receipt of the claim, any additional documentation supporting the claim or relating to defenses to the claim the local agency may have against the claimant.*  
(2) *If additional information is thereafter required, it shall be requested and provided pursuant to this subdivision, upon mutual agreement of the local agency and the claimant.*  
(3) *The local agency's written response to the claim, as further documented, shall be submitted to the claimant within 15 days after receipt of the further documentation or within a period of time no greater than that taken by the claimant in producing the additional information, whichever is greater.*
- (c) (1) *For claims of over fifty thousand dollars (\$50,000) and less than or equal to three hundred seventy-five thousand dollars (\$375,000), the local agency shall respond in writing to all written claims within 60 days of receipt of the claim, or may request, in writing, within 30 days of receipt of the claim, any additional documentation supporting the claim or relating to defenses to the claim the local agency may have against the claimant.*  
(2) *If additional information is thereafter required, it shall be requested and provided pursuant to this subdivision, upon mutual agreement of the local agency and the claimant.*  
(3) *The local agency's written response to the claim, as further documented, shall be submitted to the claimant within 30 days after receipt of the further documentation, or within a period of time no greater than that taken by the claimant in producing the additional information or requested documentation, whichever is greater.*
- (d) *If the claimant disputes the local agency's written response, or the local agency fails to respond within the time prescribed, the claimant may so notify the local agency, in writing, either within 15 days of receipt of the local agency's response or within 15 days of the local agency's failure to respond within the time prescribed, respectively, and demand an informal conference to meet and confer for settlement of the issue in dispute. Upon a demand, the local agency shall schedule a meet and confer conference within 30 days for settlement of the dispute.*
- (e) *Following the meet and confer conference, if the claim or any portion remains in dispute, the claimant may file a claim as provided in Chapter 1 (commencing with Section 900) and Chapter 2 (commencing with Section 910) of Part 3 of Division 3.6 of Title 1 of the Government Code. For purposes of those provisions, the running of the period of time within which a claim must be filed shall be tolled from the time the claimant submits his or her written claim pursuant to subdivision (a) until the time that claim is denied as a result of the meet and confer process, including any period of time utilized by the meet and confer process.*
- (f) *This article does not apply to tort claims and nothing in this article is intended nor shall be construed to change the time periods for filing tort claims or actions specified by Chapter 1 (commencing with Section 900) and Chapter 2 (commencing with Section 910) of Part 3 of Division 3.6 of Title 1 of the Government Code.*



- D. Claims for \$375,000 or below, as provided by Public Contract Code - § 20140.4(a)-(c), pertaining to Civil action procedures; mediation and arbitration; trial de novo; witnesses:

The following procedures are established for all civil actions filed to resolve claims subject to this article:

- (a) *Within 60 days, but no earlier than 30 days, following the filing or responsive pleadings, the court shall submit the matter to nonbinding mediation unless waived by mutual stipulation of both parties. The mediation process shall provide for the selection within 15 days by both parties of a disinterested third person as mediator, shall be commenced within 30 days of the submittal, and shall be concluded within 15 days from the commencement of the mediation unless a time requirement is extended upon a good cause showing to the court or by stipulation of both parties. If the parties fail to select a mediator within the 15-Day period, any party may petition the court to appoint the mediator.*
- (b) (1) *If the matter remains in dispute, the case shall be submitted to judicial arbitration pursuant to Chapter 2.5 (commencing with Section 1141.10) of Title 3 of Part 3 of the Code of Civil Procedure, notwithstanding Section 1141.11 of that code. The Civil Discovery Act (Title 4 commencing with Section 2016.010 of Part 4 of the Code of Civil Procedure) shall apply to any proceeding brought under this subdivision consistent with the rules pertaining to judicial arbitration.*
  - (2) *Notwithstanding any other provision of law, upon stipulation of the parties, arbitrators appointed for purposes of this article shall be experienced in construction law, and, upon stipulation of the parties, mediators and arbitrators shall be paid necessary and reasonable hourly rates of pay not to exceed their customary rate, and such fees and expenses shall be paid equally by the parties, except in the case of arbitration where the arbitrator, for good cause, determines a different division. In no event shall these fees or expenses be paid by state or county funds.*
  - (3) *In addition to Chapter 2.5 (commencing with Section 1141.10) of Title 3 of Part 3 of the Code of Civil Procedure, any party who after receiving an arbitration award requests a trial de novo but does not obtain a more favorable judgment shall, in addition to payment of costs and fees under that chapter, pay the attorney's fees of the other party arising out of the trial de novo.*
- (c) *The court may, upon request by any party, order any witnesses to participate in the mediation or arbitration process.*

- E. Claims for \$375,000 or below, as provided by Public Contract Code - §20140.6 (a)-(b), Payment on undisputed portion of claim; interest on arbitration awards or judgments:

- (a) *No local agency shall fail to pay money as to any portion of a claim which is undisputed except as otherwise provided in the contract.*
- (b) *In any suit filed under Section 20104.4, the local agency shall pay interest at the legal rate on any arbitration award or judgment. The interest shall begin to accrue on the date the suit is filed in a court of law.*

**SECTION 10  
SPECIAL PROVISIONS**

**For**

**City of Colfax**

**CULVER STREET PAVEMENT REHABILITATION PROJECT**

**June 2019**

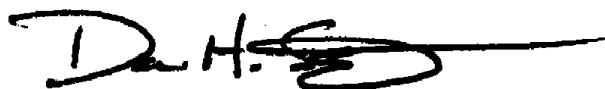

---

**Dane Schilling, RCE 56908**

June 20, 2019

---

**Date:**



11641 Blocker Drive, Suite 170  
Auburn, CA 95603  
(530) 888-9929

**10-1 GENERAL**

**10-1.01 Description of Work:**

The work in general consists of removal of existing roadway section and replacing with asphalt concrete over aggregate base pavement section, valley gutter, minor concrete, asphalt concrete dike, water service replacement, and resetting existing utilities to grade.

The estimate of the quantities of work to be done is approximate only, being as a basis for the comparison of bids, and the City does not expressly or by implication agree that the actual amount of work will correspond therewith, but reserves the right to increase or decrease the amount or any portion of the work as directed by the City Engineer.

Incidental items of construction necessary to complete the whole work in a satisfactory and acceptable manner as shown on the plans and as provided for in the specifications and not specifically referred to in this section, shall be understood to be furnished by the Contractor.

**10-1.02 Construction Limitations:**

The Contractor will be expected to conduct his operations in a manner which creates a minimum damage to the natural vegetation and landscaping, paving and gravel areas. Care shall be exercised to avoid hazards that may cause injury to persons, animals or property either during working hours or after work hours, which will include dust control, backfilling trenches or placement of steel plates and temporary fencing as required.

Equipment will be restricted to the immediate area of construction.

Receptacles for construction residue, including oil, cleaning fluids and litter, will be covered. Such residues will be disposed of in a proper manner.

Mufflers and/or baffles will be required on all construction equipment.

Construction activity within the existing right-of-way will be scheduled to minimize traffic inconvenience and safety hazards to motorists, pedestrians and cyclists.

**10-1.03 Order of Work:**

Order of work shall be in accordance with Section 5, "Control of Work," of the Standard Specifications and these Special Provisions.

Attention is directed to Section 10-2 "Construction Area Signs and Traffic Control" of these Special Provisions.

**10-1.04 Storm Water Pollution Prevention:**

Attention is directed to the provisions in Section 13, "Water Pollution Control," of the Standard Specifications and these Special Provisions.

The Contractor shall exercise every reasonable precaution to protect streams, lakes, reservoirs, bays, and coastal waters from pollution with fuels, oils, bitumens, calcium chloride and other harmful materials and shall conduct and schedule his operations so as to avoid or minimize muddying and silting of said streams, lakes, reservoirs, bays and coastal waters. Care shall be exercised to preserve roadside vegetation beyond the

limits of construction.

Water pollution control work is intended to provide prevention, control and abatement of water pollution to streams, waterways, and other bodies of water, and shall consist of constructing those facilities which may be shown on the plans, specified herein or in the special provisions, or directed by the Engineer.

Before starting any work on the project, the Contractor shall submit, for acceptance by the City Engineer, a program to control water pollution effectively during construction of the project. Such program shall show the schedule for the erosion control work included in the contract and for all water pollution control measures which the Contractor proposes to take in connection with construction of the project to minimize the effects of his operation upon adjacent streams and other bodies of water. The Contractor shall not perform any clearing and grubbing or earthwork on the project, other than that specifically authorized in writing by the Engineer, until such program has been accepted.

The City Engineer will notify the Contractor of the acceptance or rejection of any submitted or revised water pollution control program before not more than 5 working days.

**10-1.05 Temporary Erosion Control:**

Temporary erosion control shall consist of, but not be limited to, constructing such facilities and taking such measures as are necessary to prevent, control and abate water, mud, and erosion damage to public and private property as a result of the construction of this project.

Conformance with the requirements of this section shall in no way relieve the Contractor from his responsibilities, as provided in Section 13, "Water Pollution Control," Section 5-1.36, "Property and Facility Preservation," and Section 5-1.39, "Damage Repair and Restoration," of the Standard Specifications.

Temporary erosion control features as are necessary to prevent damage during the winter season shall be constructed and functioning. The Contractor shall construct such supplementary temporary erosion control facilities as are necessary to protect adjacent private and public property.

Temporary erosion control measures shall conform to the current edition of ABAG manual of standards for erosion and sediment control measures and includes, but not limited to the following:

1. The Contractor shall conduct his operations in such a manner that storm runoff will be contained within the project or channeled into the storm drain system which serves the runoff area. Storm runoff from one area shall not be allowed to divert to another runoff area.
2. The roadway shall be kept swept, and spoils from grinding, sawcutting, trenching, etc. and silt, shall be removed daily or as often as needed to prevent spoils and silt from entering the storm drain system and roadside ditches.

**10-1.06 Maintaining Traffic and Pedestrian Operations:**

The site of the work shall be enclosed by suitable barricades, signs and lights to warn and protect traffic effectively and shall be in accordance with those procedures as set by the Federal Highway Administration.

Attention is directed to Section 10-2 "Construction Area Signs and Traffic Control" of these Special Provisions.

The Contractor shall provide adequate barricades, signs, warning lights, watchmen and flagmen in accordance with the latest revision of the State of California "Manual for Warning Signs, Lights and Devices

for Use in Performing Work Upon Highways” to protect the work and the safety of the public. Warning lights using inflammable liquids will not be permitted; only electrically operated lights will be approved for use. Warning lights shall be kept burning from sunset to sunrise, and barricades shall be painted to increase their visibility at night.

**All detours and traffic control shall be limited to between 8:30 a.m. and 5:00 p.m. unless otherwise noted; one-way traffic shall be maintained from 2:30 p.m. to 5:00 p.m. (single lane traffic control with flagging) and unobstructed two-way traffic shall be maintained daily from 5:00 p.m. to 8:30 a.m.**

Attention is directed to Section 7-1.03, “Public Convenience,” and Section 7-1.04, “Public Safety,” of the Standard Specifications, which sections are hereby incorporated in these Special Provisions as if set forth in full. Attention is also directed to Section 10-1.07, “Public Safety,” of these Special Provisions.

Adequate traffic control, flagmen, signing, and barricades shall be provided by the Contractor at all times as approved by the Engineer.

**10-1.07 Public Safety:**

The Contractor shall at all times conduct his work in accordance with Construction Safety Orders of the Division of Industrial Safety, State of California, to ensure the least possible obstruction to traffic and inconvenience to the general public, and adequate protection of persons and property in the vicinity of the work.

No access way shall be closed to the public without first obtaining permission of the Engineer.

Should the Contractor fail to provide public safety as specified or if, in the opinion of the Engineer, the warning devices furnished by the Contractor are not adequate, the City may place any warning lights or barricades or take any necessary action to protect or warn the public of any dangerous condition connected with the Contractor’s operations and the Contractor shall be liable to the City for all costs incurred including, but not limited to, administrative costs.

Nothing in this section shall be construed to impose tort liability on the City or Engineer.

**10-1.08 Water for Construction and Dust Control:**

Construction and testing water shall conform to Section 10-6, “Watering,” of the Standard Specifications and these Special Provisions. The Contractor shall be responsible for providing all water necessary for construction and testing and disposing of all water needed for testing.

During the performance of the work called for under these Specifications, or any operations box thereto, the Contractor shall furnish all labor, equipment and means required, and as often as necessary, to prevent his operations from producing dust in amounts damaging to property or causing a nuisance to persons living nearby or occupying buildings in the vicinity.

**10-1.09 Protection of Existing Facilities and Property:**

The Contractor shall notify Underground Service Alert (USA) for marking the locations of existing underground facilities.

The Contractor shall take all necessary measures to avoid injury to existing surface and underground utility facilities in and near the site of the work. No error or omission of utility markouts shall be construed to relieve the Contractor from his responsibility to protect all underground pipes, conduits, cables or other

structures. The Contractor shall indemnify the City and hold it harmless from any and all claims, demands, or liability made or asserted by any person or entity on account of or in connection with any damage to such surface or underground facilities caused by the Contractor or any of his agents or subcontractors.

The existing underground facilities in the area of work may include telephone, television, fiber optic communication and electrical cables, gas mains, water mains, sewer pipe and drainage pipe. The various utility companies shall be notified before trenching begins and at such other times as required to protect their facilities. Underground facilities shall be located and exposed ahead of trenching to prevent damage to the facilities, and to determine the depth and character of all facilities that cross or infringe on the trench prism. The Contractor shall immediately notify the City Engineer of any facilities found. If damage should occur to the existing facilities, the utility company and the City shall be notified immediately and repairs acceptable to the utility company shall be made at the Contractor's expense. Contractor shall protect existing utility markers and remove and replace markers as required.

The Contractor shall preserve and protect City survey monuments and benchmarks per State of California Business and Professions Code Section 8771.

Attention is directed to the provisions in Section 5-1.36, "Property and Facility Preservation," of the Standard Specifications, which section is hereby incorporated in these special provisions as if set forth in full, and these Special Provisions.

Existing trees, shrubs, and other plants, that are not to be removed and are injured or damaged by reason of the Contractor's operations, shall be replaced by the Contractor in accordance with the requirements in Section 5-1.36, "Property and Facility Preservation," and Section 20-3.01C(4), "Replacement Plants," of the Standard Specifications. Sections 5-1.36 and 20-3.01C(4) of the Standard Specifications is hereby incorporated in these Special Provisions.

**10-1.10 Obstructions:**

Attention is directed to Sections 5-1.36D, "Non-Highway Facilities," and 15, "Existing Facilities," of the Standard Specifications, which sections are hereby incorporated in these Special Provisions as if set forth in full, and these Special Provisions.

Attention is directed to the existence of overhead power lines, power poles, and underground water mains and laterals within the area in which construction is to be performed.

**Attention is directed to existing shallow water lines, water valve boxes and water services within work area owned by Placer County Water Agency (PCWA). Prior to commencing any excavation or potholing work, the Contractor shall notify PCWA in writing a minimum of five (5) business days. Any and all work required to adjust boxes to grade, either lowering and/or raising, are to be performed by the Contractor in accordance with PCWA Improvement Standards. Contractor shall coordinate the timing of work with PCWA to avoid delay.**

Prior to starting work, the Contractor shall (a minimum of 2 working days in advance) call Underground Service Alert (USA), toll free, at (800) 642-2444 and provide USA with all necessary data relative to the proposed work. USA will accept calls and process information to participating agencies who have underground facilities in the area between the hours of 7:30 a.m. and 5:00 p.m. daily, except Saturdays, Sundays, and holidays. Between the hours of 5:00 p.m. and 7:30 a.m. calls will be recorded and then processed after 7:30 a.m. For emergency situations, after hours and on Saturdays, Sundays and holidays, the Contractor shall contact the organization owning the affected facility. Upon notification, agencies having facilities in the area of the proposed excavation will mark their locations in the field using USA standard colors and codes to identify the facility.

Any delays claimed by the Contractor as a direct result of the utility facilities not being rearranged as provided will not be recognized nor will any delays be considered right-of-way delays within the meaning of Section 8-1.07, "Delays," of the Standard Specifications, except that any such delays will entitle the Contractor to an extension of time as provided in Section 8-1.10, "Liquidated Damages," of the Standard Specifications. The Contractor shall immediately notify the Engineer of such delays.

The Contractor will be required to work around public and private utility facilities and other improvements that are to remain in place within the construction area and he will be held liable to the owners of such facilities or interference with service resulting from his operations.

**10-1.11 Hours of Work:**

The Contractor shall restrict his hours of work to 8:00 a.m. to 5:00 p.m. Monday through Friday. Deviations from these hours may be requested and approved in writing by the Engineer.

**10-1.12 Dust Control:**

Dust control shall conform to the provisions in Section 14-11.04, "Dust Control," of the Standard Specifications, which section is hereby incorporated in these special provisions as if set forth in full, and these Special Provisions.

**10-1.13 Preconstruction Conference:**

Prior to beginning any work, the Contractor shall provide the Engineer and affected agencies with a list of key and responsible personnel and how they may be reached at any time. A preconstruction conference shall be scheduled at least 72 hours prior to construction, at which time the Contractor shall be required to present his proposed work schedule, information of offsite yards, subcontractors, location of disposal and stockpile areas, and traffic control plans. All such schedules shall be subject to the approval of the Engineer and the applicable agencies.

**10-1.14 Referenced Specifications and Standards:**

All contract work will be in accordance with the County Standards, all other terms of this contract including, but not limited to, these Special Provisions, and applicable law. Provisions of the State Standards and the Standard Specifications will only apply to and be a part of this contract to the extent such provisions are expressly incorporated in these Special Provisions.

**10-1.15 Owner Notification:**

The Contractor shall notify all property owners and businesses affected by the project's work at least 48 hours before work is to begin. The notice shall be in writing, placed on doors and shall indicate the Contractor's name and phone number, type of work, day(s) and time when work will occur. Notice shall be reviewed by the Engineer prior to being posted.

Parking restrictions shall be posted 48 hours in advance along the affected construction areas. See Section 10-2.04 "Removal of On-Street Parking" of these Special Provisions.

**10-1.16 Emergency Service Providers Notifications:**

The Contractor shall furnish the name and phone number of a representative that can be contacted in the event of an emergency. Said information shall be reported to the Placer County Sheriff dispatcher, and

updated as required to provide 24-hour phone access.

**10-1.17 Cleanup:**

Attention is directed to Section 4-1.13, "Cleanup," of the Standard Specifications, which section is hereby incorporated in these Special Provision as if set forth in full.

Before final inspection of the work, the Contractor shall clean the construction site and all ground occupied by him in connection with the work, of all rubbish, excess material, falsework, temporary structures and equipment. All parts of the work shall be left in a neat and presentable condition.

Nothing herein shall require the Contractor to remove warning, regulatory, and guide signs prior to formal acceptance by the Engineer.

**10-1.18 Construction Staking:**

Attention is directed to Section 3-1.11 of the General Provisions for information on Construction Staking.

**10-1.19 Tests and Inspections:**

Attention is directed to Section 3-1.03 of the General Provisions for information on Inspection and Testing of Work and Material.

**10-1.20 Payment:**

Full compensation for conforming to the provisions of this section shall be considered as included in the contract price paid for various other items of work and no additional allowance will be allowed.



**10-2 CONSTRUCTION AREA SIGNS & TRAFFIC CONTROL**

**10-2.01 Construction Area Signs:**

Temporary construction area signs are required for the direction of public vehicle and pedestrian traffic through or around the work during construction.

Construction area signs shall be furnished, installed, maintained and removed when no longer required in accordance with the provisions in Section 12, “Temporary Traffic Control,” of the Standard Specifications, Caltrans Standard Plan T13, the California MUTCD Part 6, and these Special Provisions. Sections 6-1.16, “Public Convenience,” and 6-1.17, “Public Safety,” of the Standard Specifications set forth the Contractor’s responsibilities for public convenience and public safety are hereby incorporated in these Special Provisions as if set forth in full and are considered to be part of the contract requirements.

Construction area signs shall not be used until they are needed and when no longer needed they shall be removed from the site of the work.

**10-2.02 Maintaining Traffic:**

Attention is directed to Section 6-1.16, “Public Convenience,” Section 6-1.17, “Public Safety,” and Section 12 “Temporary Traffic Control,” of the Standard Specifications, which sections are hereby incorporated in these Special Provisions as if set forth in full. Nothing in these Special Provisions shall be construed as relieving the Contractor from his responsibilities as provided in said Section 6-1.17.

**10-2.03 Traffic Control Plan:**

It is the responsibility of the Contractor to provide a Traffic Control Plan five (5) working days prior to beginning construction. Work shall not begin until the plan is approved by the Engineer.

The content of the Traffic Control Plan shall include, but not be limited to, the following:

- a. Show location and limits of the work zone.
- b. Give dimensions of lanes affected by traffic control that will be open to traffic.
- c. Indicate signing, cone placement, and other methods of delineation and reference to appropriate City or Caltrans standard.
- d. Dimension location of signs and cone tapers.
- e. Identify side streets and driveways affected by construction and show how they will be handled.
- f. Show how pedestrian traffic will be handled through the construction site.
- g. Demonstrate how two-way traffic will be maintained.

No work except for the installation of project identification signage will be allowed to commence prior to approval of the work zone Traffic Control Plan.

**10-2.04 Removal of On-Street Parking:**

Forty-eight (48) hours prior to construction, the Contractor shall place barricades signed “NO PARKING – TOW AWAY – Specific Time and Date(s)” at 100 foot intervals or a minimum of 2 signs per block, whichever is greater, in the work area. “NO PARKING” signs must also state “C.V.C. 22651 (L)”. See example below.

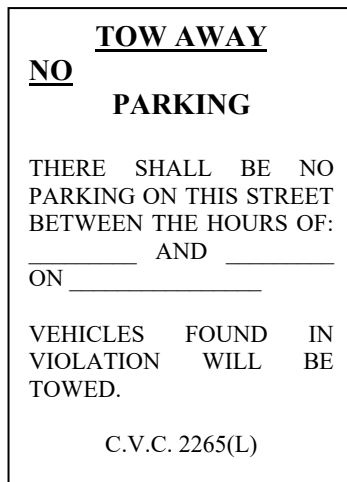

“NO PARKING – TOW AWAY” signs shall be submitted for approval by the Engineer prior to their use. The Contractor shall notify the Engineer immediately after the “NO PARKING” signs are in place. “NO PARKING” signs and barricades shall be supplied by the Contractor.

Failure to comply with this section will prevent the City from towing vehicles parked in the proposed work area. Any resulting delay will be the responsibility and at the expense of the Contractor. Section 12-1.03, “Flagging Costs,” of the Standard Specifications is hereby incorporated in these Special Provisions as if set forth in full and is amended to read:

The total cost of furnishing all flaggers will be borne solely by the Contractor.

**10-2.05 Contractor Staging Area:**

Contractor shall not utilize public streets or parking spaces for overnight or weekend storage of vehicles, equipment or materials unless approved by the Engineer.

**10-2.06 Measurement and Payment:**

Full compensation for furnishing all labor, materials, tools, equipment and incidentals, and for doing all the work involved including, but not limited to, erecting, covering and uncovering as required, maintaining and removing construction area signs will be considered as included in the **lump sum** price paid for **Traffic Control** and no additional compensation will be allowed therefore.

**10-3 TRAFFIC CONTROL**

**10-3.01 Maintaining Traffic:**

Construction area traffic control devices shall be installed and maintained in accordance with the applicable sections of these Special Provisions, the current edition of the California Manual of Uniform Traffic control Devices (CAMUTCD) and as directed by the Engineer.

Attention is directed to Section 6-1.16, "Public Convenience," Section 6-1.17, "Public Safety," and Section 12 "Temporary Traffic Control," of the Standard Specifications, which sections are hereby incorporated in these Special Provisions as if set forth in full. Nothing in these Special Provisions shall be construed as relieving the Contractor from his responsibilities as provided in said Section 6-1.17 of these Special Provisions.

Street closures with detoured traffic will be permitted between the hours of 8:30 a.m. and 5:00 p.m. only unless specifically approved by the Engineer. The Contractor shall maintain vehicle access to properties at all times while work is in progress.

Streets (or sections of streets) to be rehabilitated shall be closed to all but emergency (police, fire and ambulance) vehicles during the construction period. The closures shall be subject to the following conditions:

1. Streets shall be closed for as short a time as possible, and in all cases shall be opened for use by the public prior to 8:30 AM and after 5 PM on Monday through Friday, all day on Saturday and Sunday, all day on designated holidays, and when construction operations are not actively in progress (unless noted otherwise on the Project Plans or within the Special Provisions provided for the project).
2. The Contractor shall furnish and install C3A signs (ROAD CLOSED TO THRU TRAFFIC) at the entrance to all streets that "dead end" due to road closures for slurry sealing operations. All signs shall be provided, installed, and maintained by the Contractor.
3. The Contractor shall notify each residence of planned roadway construction adjoining their properties two weeks prior to such work by furnishing and delivering printed material (i.e., Door Hangers) to each residence indicating when their street and adjacent streets will be closed for roadway construction.

A second notification (i.e., Door Hangers) shall be furnished and delivered three (3) calendar days in advance of such work.

4. The Door Hanger proposed for use by the Contractor must be reviewed and approved by the Engineer prior to distribution.
5. During street closures, residences along the street shall be provided pedestrian passage as far as practical. Convenient pedestrian access to driveways, houses and buildings along the street shall be maintained.
6. Pedestrian access shall be provided at intersections or at other locations as directed by the Engineer. Placing sand or aggregate, or laying down a strip of building paper or other approved material shall be the methods used to provide pedestrian access. The pedestrian access shall be a minimum of forty-eight inches (48") wide.

7. The Contractor shall install Type II barricades with "No Parking" signs and shall clearly mark the date(s) and hours that NO PARKING ZONES shall be in effect. The dates posted on the barricades must match the dates that the work is scheduled to be performed at the location posted. Barricades shall be spaced at one hundred (100) foot intervals or less on both sides of streets. These signs shall be posted no less than 72 hours (three calendar days) in advance of the roadway construction operations.
8. The Contractor shall be responsible for re-notifying all affected residences in the event that a street needs to be rescheduled due to unforeseen delays. Re-notification shall be furnished and delivered 72 hours (three calendar days) in advance of such work. The Contractor shall also be responsible for re-posting of "No Parking" signs and barricades.

The Contractor shall not park construction vehicles in front of businesses on any blocks open to public access.

The Contractor shall keep the Placer County Sherriff Department and City of Colfax Fire Department informed regarding the closure of any traveled way. The Contractor shall notify Transit Authority and the local Postal Service five (5) calendar days prior to any lane closures or restrictions in turning movements.

If the Contractor has been given an approved Traffic Control Plan that includes road closures, they will be required to maintain vehicular access to properties where work is in progress within the closure area.

Seventy-two (72) hours prior to construction, the Contractor shall place a notice on each front door, and attempt to notify each owner or tenant verbally that work will be underway within his block between stated hours, and request that cars be parked out of the roadway by 8:00 a.m. Service of notice shall not bar use of local cars within the block; however, as individual plans change and emergencies may arise.

Section 12-1.04, "Flagging Costs," of the Standard Specifications is hereby incorporated in these Special Provisions as if set forth in full and is amended to read:

The total cost of furnishing all flaggers will be borne solely by the Contractor. The cost of furnishing all flaggers, including transporting flaggers, to provide for passage of public traffic through the work under the provisions in Section 6-1.16, "Public Convenience", and Section 6-1.17, "Public Safety", shall be considered as included in the contract lump sum price paid for traffic control and no additional allowance will be made therefor.

**10-3.02 Traffic Control Plan:**

It is the responsibility of the Contractor to provide a Traffic Control Plan five (5) working days prior to beginning construction. Work shall not begin until the plan is approved by the Engineer.

The content of the Traffic Control Plan shall include, but not be limited to, the following:

- a. Show location and limits of the work zone.
- b. Give dimensions of lanes affected by traffic control that will be open to traffic.
- c. Detour plan.
- d. Indicate signing, cone placement, and other methods of delineation and reference to appropriate City or Caltrans standard.
- e. Dimension location of signs and cone tapers.
- f. Identify side streets and driveways affected by construction and show how they will be handled.
- g. Show how pedestrian traffic will be handled through the construction site.
- h. Demonstrate how two-way traffic will be maintained for streets not being closed.

No work except for the installation of project identification signage will be allowed to commence prior to approval of the work zone Traffic Control Plan.

**10-3.03 Measurement and Payment:**

Full compensation for furnishing all labor (including flagging costs), materials (including traffic control and construction area signs), Traffic Control Plan, tools, equipment, and incidentals and for doing all the work involved in placing, removing, storing, maintaining, and moving to new locations, replacing, and disposing of the components of the traffic control system, as specified in the Standard Specifications and these Special Provisions, and as directed by the Engineer will be considered included in the contract **lump sum** price paid for **Traffic Control** and no additional compensation will be allowed therefore.

**10-4 EXISTING FACILITIES**

**10-4.01 Existing Facilities:**

The work performed in connection with various existing highway facilities shall conform to the provisions in Section 15, “Existing Facilities,” of the Standard Specifications and these Special Provisions.

**10-4.02 Removal of Miscellaneous Items:**

Various items shown on the Plans to be removed will be completely removed and disposed of. All traffic stripes, pavement markers and pavement markings shall be removed by sandblasting or grinding and shall not materially damage the existing pavement. Where grinding is used, grinding of the pavement surface shall be limited to a maximum depth of 1/16”. Removal of pavement markers shall conform to the provisions of Sections 15-2.02D of the Standard Specifications and these Special Provisions. Residue from the removal of traffic stripes, pavement markings, and pavement markers shall be swept or vacuumed from the street surface and disposed of immediately after removal. Residue shall not be allowed to enter the storm drain system or creeks and roadside ditches. Disposal shall be performed in accordance with Section 6-1.20, “Disposal of Material Outside the Right of Way,” of the General Provisions.

**10-4.03 Sawcut Pavement:**

Where no joint exists in concrete or asphalt concrete to be removed and concrete or asphalt concrete to remain in place, the concrete or asphalt concrete shall be cut in neat lines to a minimum depth of 0.17 foot with a power driven saw before the concrete or asphalt concrete is removed.

**10-4.04 Adjust Manhole Frame and Cover to Grade:**

Existing manhole frames and covers of the various types shall be adjusted to the final pavement grade, complete and in place in accordance with the Plans and these special provisions.

The Contractor shall accurately locate and record the location of all manhole covers to be raised to grade and shall furnish the City Engineer a copy of said record prior to resurfacing.

Waste materials generated while adjusting the manhole and utility frame and cover to grade shall be completely removed and disposed of in accordance with Section 5-1.20B(4) “Contractor-Property Owner Agreement,” of the Standard Specifications.

Concrete used for collars shall conform to the provisions in Section 90-2, “Minor Concrete,” of the Standard Specifications.

All sections of manhole frames and grade rings shall be set in Portland Cement Concrete the same day that the grade rings are placed. Contractor shall let the concrete collar cure for 24 hours prior to traffic loading. Asphalt concrete paving over Portland Cement Concrete shall be installed by the end of the following calendar day.

Adjustment of manhole frames and covers shall be in accordance with Section 71-5.03B, “Frames, Covers, Grates, and Manholes” of the Standard Specifications.

Contractor is responsible to remove and dispose of any construction related debris. Portions of the existing facilities that are to remain in place must be protected, preserved, and maintained. If contractor damages a portion of the facility that is to remain in place, contractor must repair or replace the damaged facility. After

completion of the project, the condition of the facility must be equal or better in quality than it was before beginning the work.

**10-4.05 Adjust Water Valve Frame And Cover To Grade:**

Existing water valve box and cover shall be adjusted to the final pavement grade, complete and in place in accordance with the details on the plans.

The Contractor shall accurately locate and record the location of all valve covers to be raised to grade and shall furnish the Engineer a copy of said record prior to resurfacing. Contractor shall place a white paint dot at each covered valve box the day they are covered and raise all valve boxes within 72 hours of covering them.

Waste materials generated while adjusting the water valve box frame and cover to grade shall be completely removed and disposed of in accordance with Section 5-1.20B(4), "Contractor-Property Owner Agreement" of the Standard Specifications.

Concrete used for collars shall conform to the provisions in Section 90-2, "Minor Concrete," of the Standard Specifications. Portland Cement Concrete shall contain no less than 505 pounds of cementitious material per cubic yard and have a minimum compressive strength of 3,000 psi.

**10-4.06 Measurement and Payment:**

**Removal or Removal and Replacement of Miscellaneous Items:** No separate measurement or payment shall be made for the various items to be removed or removed and replaced (such as brick pavers, through curb drains, traffic stripes, pavement markers and markings) unless specified and listed in the Bid Schedule. Full compensation for conforming to the requirements of this section shall be considered as included in the contract prices paid for the various contract items of work and no additional compensation will be allowed.

**Sawcut Pavement:** No separate measurement or payment will be made for sawcutting. Full compensation for sawcutting shall be considered as included in the contract prices paid for the various contract items of work requiring sawcutting and no additional compensation will be allowed.

**Adjust Manhole Frame and Cover to Grade:** Full compensation for furnishing all labor, materials, tools and equipment, and doing all the work involved in adjusting manhole frame and cover to grade as herein specified, including, but not limited to excavation, backfill, concrete, additional grade rings if required, pavement and mortar, furnishing location of existing boxes and covers to be adjusted to grade, removing silt and debris will be measured per **each** from actual count as shown on the plans, as specified in these Special Provisions and as directed by the Engineer and paid at the contract unit price for **Adjust Manhole Frame and Cover to Grade** and no additional compensation will be allowed.

**Adjust Water Valve to Grade:** Full compensation for furnishing all labor, materials, tools, equipment and incidentals, and for doing all the work involved in adjusting water valve frame and cover to grade as herein specified, including, but not limited to, excavation, backfill, concrete, grade rings, pavement and mortar will be measured per **each** from actual count as shown on the plans, as specified in these Special Provisions and as directed by the Engineer and paid at the contract unit price for **Adjust Water Valve to Grade** and no additional compensation will be allowed.

**10-5 ROADWAY EXCAVATION**

**10-5.01 Roadway Excavation:**

Roadway excavation shall conform to the provisions in Section 19-2, "Roadway Excavation", of the Standard Specifications and these Special Provisions.

Roadway excavation shall include the removal of the roadway prism within the limits for roadway construction, removal and disposal of asphalt concrete pavement, aggregate base, subgrade and native material, at the locations shown on the plans. Removal shall be to the lines and grades shown, specified or determined by the Engineer.

Surplus materials from the excavation shall become the property of the Contractor and shall be disposed of by him, at his expense. The excavated roadway material shall be disposed of outside the right of way in accordance with Section 5-1.20B(4), "Contractor-Property Owner Agreement" of the Standard Specifications.

No separate measurement will be made for removal of asphalt concrete, existing bituminous pavement and base materials.

Excavation in excess of the planned or authorized cross section will not be paid for. The Contractor shall backfill and compact, as directed by the Engineer, unauthorized excavated areas at his expense.

**10-5.02 Measurement and Payment:**

**Roadway Excavation** shall be measured and paid for by **cubic yard**. The contract **cubic yard** unit price paid for **Roadway Excavation** shall include full compensation for furnishing all labor, materials, tools, equipment and incidentals and for doing all the work involved but not limited to, excavating asphalt concrete, aggregate base, and subgrade of roadways, loading, hauling and disposing of the excavated material, as shown on the plans, as specified in these Special Provisions, the Standard Specifications and as directed by the Engineer and no additional compensation will be allowed.

The contract item quantity for Roadway Excavation is designated as a final pay quantity in accordance with Section 9-1.02(C), "Final Pay Item Quantities," of the Standard Specifications.



**10-6 ASPHALT CONCRETE**

**10-6.01 Asphalt Concrete:**

Asphalt concrete base and asphalt concrete surface and the placing thereof shall conform to the requirements of Section 39, "Hot Mix Asphalt," of the 2010 Standard Specifications and Section 39-2 "Standard Construction Process", with the following modifications:

Aggregate shall be ½" HMA Type A for the asphalt concrete course. Paving asphalt shall be PG64-16 conforming to the latest published provisions in Section 92, "Asphalts," of the Standard Specifications.

The Contractor shall furnish the Owner's Engineer, at least ten (10) working days prior to the start of work, a list of sources of materials together with a Certified of Compliance indicating that materials to be incorporated in the work fulfill the requirements of these specifications and a mix design for the asphalt concrete. The mix design shall be performed in accordance with CTM 366 and 367. The Certified of Compliance shall be signed by the material supplier or his representative. The Contractor shall be responsible for all costs associated with the required mix design.

A tack coat, of a type compatible with geosynthetic pavement interlayer, shall be applied to all mating surfaces along and at conforms to existing pavement prior to placement of new asphalt concrete and shall conform to Section 94, "Asphaltic Emulsions" of the Standard Specifications.

Tack coat shall be applied between all asphalt concrete lifts.

The Contractor shall use asphalt spreading machinery with automated controls. No trucks or other equipment shall be allowed on the subgrade at any time. Trucks or other construction equipment shall not be allowed on the newly placed asphalt concrete until the day after it is placed. Super Dumps or other trucks with liftable trailing load bearing axles shall not be allowed on the newly placed asphalt concrete at any time unless specifically approved by the Engineer. All trucks or other construction equipment to be driven on the newly placed asphalt concrete shall not exceed the surface load bearing capacity and shall not produce rutting or pumping at any time.

Construction shall be in accordance with Section 39-3 "Method Construction Process" of the Standard Specifications. Asphalt concrete shall be compacted to 91-97% of maximum theoretical density (CT 309) as determined by CT 375 (a nuclear density device may be used). A profilograph will not be required.

A drop-off of more than 0.15-foot will not be allowed at any time between adjacent lanes open to public traffic. Attention is directed to Section entitled, "Maintaining Traffic" of these Special Provisions. Temporary asphalt concrete tapers or grinding of the existing pavement edge shall be used to provide a slope of 30:1, or flatter, between adjacent lanes open to traffic.

**10-6.02 Asphalt Concrete Dike:**

Asphalt Concrete Dike shall be Type E per Placer County Standard Number 122 as noted on the plans and conform to the provisions of Section 39-2.01B(11), "Miscellaneous Areas and Dikes," of the Standard Specifications and these Special Provisions.

**10-6.03 Pavement Reinforcing Fabric**

10.7.03(A) Pavement Preparation

Pavement surfaces shall be clean and dry prior to application of pavement reinforcing fabric. Cleaning shall be performed by sweeping with power equipment to remove all loose particles of pavement and grindings, all dirt and other extraneous material.

All traffic stripes, pavement markers and pavement markings shall be removed unless otherwise directed by the Engineer. Traffic stripes and pavement markings shall be removed by sandblasting or grinding and shall not materially damage the existing pavement. Where grinding is used, grinding of the pavement surface shall be limited to a maximum depth of 1/16”.

Residue from the removal of traffic stripes, pavement markings, and pavement markers shall be swept or vacuumed from the street surface and disposed of immediately after removal. Residue shall not be allowed to enter the storm drain system or creeks and roadside ditches. Disposal shall be performed in accordance with Section 6-1.20 "Disposal of Material Outside the Right of Way," of the General Provisions.

10-6.03(B) Reinforcing Fabric

Pavement reinforcing fabric shall be placed in resurface areas as shown on the plans and as directed by the Engineer. Unless otherwise noted, pavement reinforcing fabric shall be Tensar GlasPave 25 or approved equivalent and shall conform to these special provisions and Section 96, “Geosynthetics,” of the Standard Specifications and shall be placed in accordance with the requirements of Section 39-2.01B(9) and 39-2.01C(3)(g), “Geosynthetic Pavement Interlayer,” of the Standard Specifications.

Pavement reinforcing fabric shall be installed in accordance with the manufacturer’s recommendations and these Special Provisions. Tack coat shall be applied with a distributor truck equipped to spray a uniform film of tack. The distributor must be capable of maintaining proper temperature, pressure and spray bar height to apply the correct tack coat rate. Surface and ambient air temperatures during installation shall be 50°F and rising to allow adequate liquid tack to hold the reinforcing fabric in place. All adjacent reinforcing fabric material shall be overlapped a minimum of 2 to 4 inches.

Fabric shall not be opened up to traffic until a layer of asphalt concrete is placed on top. Placement of fabric and paving of the asphalt concrete overlay shall be completed within the same work shift.

**10-6.04 Measurement and Payment:**

**Asphalt Concrete** will be measured by tonnage.

**Asphalt Concrete** will be paid for at the contract price per ton, which price shall include full compensation for furnishing all labor, materials, tools, and equipment, and doing all work involved in placing asphalt concrete, including but not limited to pavement preparation, tack coat, compaction and no additional compensation will be allowed.

Section 9-1.07, “Payment Adjustments for Price Index Fluctuations”, of the Standard Specifications shall not apply. No adjustments in payment will be made for fluctuations in the cost of asphaltic materials.

**Asphalt Concrete Dike**, shall be paid for at the contract price per **linear foot** in place in addition to the price paid for the asphalt required. Full compensation for furnishing all labor, material, tools, and equipment, and doing all work involved in constructing asphalt concrete dikes, including but not limited to pavement preparation, tack coat, spreading and compacting, and no additional compensation will be allowed.

**Pavement Reinforcing Fabric** will be measured and paid for by the **square yard**, based on the net area of coverage. The contract price paid per square yard for pavement reinforcing fabric shall include full compensation for furnishing all labor, materials, tools, equipment, and incidentals and for doing all the work involved in providing pavement reinforcing fabric, complete in place. Full compensation for pavement preparation, asphalt binder for pavement reinforcing fabric, and for furnishing and spreading sand to cover exposed binder material if necessary, shall be considered as included in the contract price paid per square yard for pavement reinforcing fabric and no additional compensation will be allowed.

In the event of an increase or a decrease in the amount of the Engineer's Estimated quantity of Pavement Reinforcement Fabric, such increase or decrease shall not be considered an alteration in excess of the 25 percent of the contract amount of such items under provisions of Section 4-1.05A of the Standard Specifications and no adjustment of the contract price for Pavement Reinforcing Fabric will be made by reason of such increase or decrease.

**10-7 MINOR CONCRETE**

**10-7.01 General**

Section 10-7 includes general specifications for construction concrete valley gutters.

**10-7.02 Minor Concrete**

Concrete valley gutters shall be constructed in accordance with Section 73, "Concrete Curbs and Sidewalks," of the Standard Specifications, and the details shown on the plans. Concrete used to construct valley gutters shall be minor concrete in accordance with Section 90-2, "Minor Concrete," of the Standard Specifications. Portland Cement Concrete for shall contain no less than 505 pounds of cementitious material per cubic yard and have a minimum compressive strength of 3,000 psi.

Attention is directed to Section 10-1.09, "Protection of Existing Facilities and Property," of these Special Provisions with regard to damage to existing improvements and landscaping.

Attention is also directed to Section 10-1.06 "Maintaining Traffic and Pedestrian Operations" of these Special Provisions.

All soft or spongy subgrade material within valley gutter areas shall be removed and replaced with suitable material as required by the Engineer. Aggregate base shall be placed under all minor concrete, as specified below and as shown on the Plans.

Prior to placement of the aggregate base, the subgrade soil shall be scarified to the depth shown on the plans, uniformly moisture conditioned above optimum moisture content, and compacted to at least 95 percent relative compaction to form a firm, non-yielding surface.

Aggregate base shall be placed under all minor concrete, as shown on the Plans. Aggregate base shall be Class 2 Aggregate Base, 3/4" maximum gradation, in accordance with Section 26-1.02B, "Class 2 Aggregate Base," of the Standard Specifications and to these Special Provisions. Aggregate base material shall be compacted to 95% of maximum relative compaction.

Reinforcement shall conform to the requirements of Section 52, "Reinforcement," of the Standard Specifications.

The Engineer shall be notified 24 hours prior to concrete pour. The Contractor shall provide string lines and forms delineating the proposed concrete surface for Engineer observation a minimum of 4 (four) hours prior to concrete pour. No concrete shall be poured until Engineer has approved the forms.

All oil, paint, tire, graffiti and other marks shall be removed from all minor concrete construction by sandblasting or complete replacement prior to acceptance by the Engineer. Cement mortar will not be an acceptable substitute for sandblasting or complete replacement.

All grade differentials adjacent to new concrete over 1" shall be backfilled with native soil at a 4:1 maximum slope and compacted to 90% relative compaction. No separate payment will be made for backfilling and compaction of native soil.

**10-7.03 Measurement and Payment**

**Minor Concrete, Valley Gutter** will be paid for at the contract price per square foot, which price shall include full compensation for furnishing all labor, materials, tools and equipment, and doing all the work

involved in constructing valley gutter in place complete as herein specified, including:

- excavation,
- sawcutting,
- subgrade preparation,
- portland cement concrete,
- forms,
- furnishing and placing backfill,
- compaction,
- reinforcing,
- furnishing and placing Class 2 aggregate base cushion,
- furnishing and placing expansion joint filler,
- constructing weakened plane joints,
- furnishing and applying curing materials,
- removing discoloration,

and any other work necessary to construct curb and gutter not specifically enumerated in the Plans or Specifications, and no additional allowance will be made therefore.

**10-8 DRAINAGE FACILITIES**

**10-8.01 Drainage Structures & Connections:**

Drainage structures shall conform to the details shown on the plans and the provisions in Section 70, "Miscellaneous Drainage Facilities," of the Standard Specifications and these Special Provisions.

Drainage inlets shall be of the types and sizes as specified on the improvement plans. At the option of the Contractor, drop inlets and bases may be poured in place or furnished and installed as precast units. Drainage inlets and grates shall be capable of supporting H-20 wheel loading.

Concrete used for drainage structures shall conform to the provisions in Section 90-2, "Minor Concrete," of the Standard Specifications. Portland Cement Concrete shall contain no less than 590 pounds of cementitious material per cubic yard and have a minimum compressive strength of 3,000 psi.

Reinforcement shall be Grade 60 conforming to the provisions of Section 52, "Reinforcement," of the Standard Specifications.

**10-8.02 Storm Drain Pipe:**

All storm drains, culverts and related appurtenances shall be constructed in accordance with the Standard Specifications, City Standards and these Special Provisions.

**Materials:** Storm drain pipe shall conform to the provisions of the Standard Specifications and these Special Provisions.

Storm drain pipe shall be High Density Polyethylene (HDPE). HDPE storm drain pipe shall conform to the provisions of Section 64, "Plastic Pipe" of the Standard Specifications. HDPE pipe shall be type S corrugated polyethylene pipe with a smooth inner lining and corrugated outer wall.

**Excavation and Backfill:** Excavation and backfill shall be in accordance with Placer County Plate, these Special Provisions and as directed by the Engineer.

**Laying Pipe:** Unless otherwise specifically permitted by the Engineer, all pipes shall be laid upgrade.

All pipe joints shall be sealed with grout or by use of a rubber gasket. A joint lubricant recommended by the pipe manufacturer shall be used on gasket sealed pipe. All excess grout shall be removed from inside the pipe.

**10-8.03 Measurement and Payment:**

**Drainage Structures, of the various types,** will be measured by **each**. No separate measurement will be made for connecting storm drain lines to existing drainage structures, miscellaneous iron and steel, and Class 2 aggregate base under drainage structures.

**Drainage Structures, of the various types,** will be paid for at the contract price per **each** for specified types and sizes as installed, which price shall include full compensation for furnishing all labor, materials, tools, equipment, and doing all the work involved in placing drainage structures as specified herein:

- excavation,
- removal of existing drainage structure,
- removal of existing storm drain pipe,

- placing and compacting all required bedding and backfill,
- trench plates (as needed),
- miscellaneous iron and steel,
- grates,
- connecting to existing storm drain,
- dewatering trench,
- disposal of soil and groundwater,
- CDF backfill

and any other work required for placing drainage structures not specifically enumerated on the plans or in these specifications and no additional allowance will be made therefor.

**Storm Drain Pipe**, of the various types, will be measured by the **lineal foot** of pipe installed. **Storm Drain Pipe**, of the various sizes, will be paid for at the contract price per **lineal foot** installed, which price shall include full compensation for furnishing all labor, materials, tools, equipment, and doing all the work involved in placing or extending drainage structures as specified herein:

- excavation,
- removal of existing storm drain pipe,
- potholing,
- placing and compacting all required bedding and backfill,
- trench plates (as needed),
- miscellaneous iron and steel,
- pipe joints,
- connecting to existing pipes,
- concrete collars,
- dewatering trench,
- disposal of soil and groundwater,

and any other work required for placing or extending storm drain pipe not specifically enumerated on the plans or in these specifications and no additional allowance will be made therefor.

**10-9 WATER LINE PROTECTIVE CAP****10-9.01 Description:**

Water lines within pavement reconstruction limits shall be protected in place by the Contractor and a water line protective cap shall be installed within the project limits as shown on the plans.

**10-9.02 Materials**

Cement slurry shall be a 2-sack mixture in accordance with Section 19-3.02E “Slurry Cement Backfill” of the Standard Specifications. Cement slurry mixture shall be reviewed and approved by the Engineer prior to ordering of materials.

**10-9.03 Construction**

Attention is directed to Section 10-1.10 of these Special Provisions regarding coordination with PCWA.

Prior to excavation along the water line(s), the Contractor shall pothole the water lines within the pavement reconstruction limits to determine the exact location and depth. Contractor to provide the Engineer with pothole results.

After potholing, the Contractor shall carefully excavate material as required to provide the water line protective cap as shown on the plans (a minimum of ten (10) inches thick below the new pavement section. The water lines shall be protected in place and any damage to the water line shall immediately be reported to PCWA. Subgrade material within the limits of the cement slurry shall remain undisturbed, without compaction or receiving construction equipment traffic.

Contractor shall place the cement slurry at the locations, width, and thickness as shown on the plans. Place cement slurry within one (1) hour of mixing. Place it in a uniform manner that prevents voids or segregation of the backfill. Remove foreign materials that falls into the excavation.

Cement slurry shall be allowed to cure in place a minimum of five (5) days or to the satisfaction of the Engineer prior to permanent pavement is placed. The surface of the cement slurry shall be firm and unyielding. Any visible movement vertically or horizontally of the cement slurry under the action of construction equipment or other maximum legal axle loads shall be considered as evidence that the cement slurry does not meet this requirement.

**10-9.04 Trench Plating**

Contractor to provide trench plates over water line protective cap(s) to allow two-way vehicular traffic on Culver Street, access to private driveways, and adjacent roadways to the satisfaction of the Engineer.

Trench plates shall be skid resistant steel plates (with a coefficient of friction of 0.35 or greater per CTM342), capable of sustaining normal (H20) traffic loads without shifting or bouncing and shall be secured per Caltrans requirements. Plates that have areas where the skid resistant material is missing shall not be used and must be removed from the job site. Hot mix asphalt concrete shall be placed and compacted around all edges of steel plates with a sufficient width and gradual slope in order to provide a smooth transition to existing pavement.



**10-9.05 Measurement and Payment:**

**Water Line Protective Cap** shall be measured and paid for by **cubic yard**. The contract **cubic yard** unit price paid for **Water Line Protective Cap** shall include full compensation for furnishing all labor, materials, tools, equipment and incidentals and for doing all the work involved but not limited to, potholing, excavation, cement slurry, curing time, trench plating, loading, hauling and disposing of the excavated material, as shown on the plans, as specified in these Special Provisions, the Standard Specifications and as directed by the Engineer and no additional compensation will be allowed.

The contract item quantity for **Water Line Protective Cap** is designated as a final pay quantity (F) in accordance with Section 9-1.02(C), "Final Pay Item Quantities," of the Standard Specifications.

**10-10 MOBILIZATION**

**10-10.01 Mobilization:**

Mobilization shall consist of preparatory work and operations, including, but not limited to, those necessary for the movement of personnel, equipment, supplies and incidentals to the project site; for establishment of all offices and other facilities necessary for work on the project; and for all other work and operations which must be performed or costs incurred prior to beginning work on the various contract items on the project site.

**10-10.02 Measurement and Payment:**

Mobilization will be measured and paid for on a lump sum basis in accordance with the provisions of Section 9-1.16D, "Mobilization," of the Standard Specifications.

**APPENDIX A**

**Labor Compliance and Federal Contract Regulations  
and Provisions**

General Decision Number: CA190007 05/03/2019 CA7

Superseded General Decision Number: CA20180009

State: California

Construction Types: Building, Heavy (Heavy and Dredging) and Highway

Counties: Alpine, Amador, Butte, Colusa, El Dorado, Glenn, Lassen, Marin, Modoc, Napa, Nevada, Placer, Plumas, Sacramento, Shasta, Sierra, Siskiyou, Solano, Sonoma, Sutter, Tehama, Trinity, Yolo and Yuba Counties in California.

BUILDING CONSTRUCTION PROJECTS (excluding Amador County only); DREDGING CONSTRUCTION PROJECTS (does not include hopper dredge work); HEAVY CONSTRUCTION PROJECTS (does not include water well drilling); AND HIGHWAY CONSTRUCTION PROJECTS

Note: Under Executive Order (EO) 13658, an hourly minimum wage of \$10.60 for calendar year 2019 applies to all contracts subject to the Davis-Bacon Act for which the contract is awarded (and any solicitation was issued) on or after January 1, 2015. If this contract is covered by the EO, the contractor must pay all workers in any classification listed on this wage determination at least \$10.60 per hour (or the applicable wage rate listed on this wage determination, if it is higher) for all hours spent performing on the contract in calendar year 2019. If this contract is covered by the EO and a classification considered necessary for performance of work on the contract does not appear on this wage determination, the contractor must pay workers in that classification at least the wage rate determined through the conformance process set forth in 29 CFR 5.5(a)(1)(ii) (or the EO minimum wage rate, if it is higher than the conformed wage rate). The EO minimum wage rate will be adjusted annually. Please note that this EO applies to the above-mentioned types of contracts entered into by the federal government that are subject to the Davis-Bacon Act itself, but it does not apply to contracts subject only to the Davis-Bacon Related Acts, including those set forth at 29 CFR 5.1(a)(2)-(60). Additional information on contractor requirements and worker protections under the EO is available at www.dol.gov/whd/govcontracts.

Modification Number	Publication Date
0	01/04/2019
1	02/01/2019
2	02/15/2019
3	02/22/2019
4	05/03/2019

\* ASBE0016-001 01/01/2019

AREA 1: MARIN, NAPA, SAN BENITO, SAN FRANCISCO, SOLANO, & SONOMA COUNTIES

AREA 2: ALPINE, AMADOR, BUTTE, COLUSA, EL DORADO, GLENN, MODOC, NEVADA, PLACER, PLUMAS, SACRAMENTO, SHASTA, SIERRA, SISKIYOU, SUTTER, TEHEMA, TRINITY, YOLO, & YUBA COUNTIES

Asbestos Workers/Insulator  
(Includes the application of  
all insulating materials,  
Protective Coverings,  
Coatings, and Finishes to all  
types of mechanical systems)

	Rates	Fringes
Area 1.....	\$ 68.11	23.32
Area 2.....	\$ 43.81	31.22

-----  
\* ASBE0016-007 01/01/2019

AREA 1 : ALPINE, AMADOR, BUTTE, COLUSA, EL DORADO, GLENN,  
LASSEN, MODOC, NEVADA, PLACER, PLUMAS, SACRAMENTO, SHASTA,  
SIERRA, SISKIYOU, SOLANO, SONOMA, SUTTER, TEHAMA, TRINITY, YOLO  
& YUBA COUNTIES

AREA 2: MARIN & NAPA COUNTIES

	Rates	Fringes
--	-------	---------

Asbestos Removal  
worker/hazardous material  
handler (Includes  
preparation, wetting,  
stripping, removal,  
scrapping, vacuuming, bagging  
and disposing of all  
insulation materials from  
mechanical systems, whether  
they contain asbestos or not)

AREA 1.....	\$ 28.20	9.27
AREA 2.....	\$ 36.53	9.27

-----  
BOIL0549-002 10/01/2016

	Rates	Fringes
--	-------	---------

BOILERMAKER

(1) Marin & Solano Counties.	\$ 43.28	37.91
(2) Remaining Counties.....	\$ 39.68	35.71

-----  
BRCA0003-001 08/01/2017

	Rates	Fringes
--	-------	---------

MARBLE FINISHER.....	\$ 32.60	15.31
----------------------	----------	-------

-----  
BRCA0003-004 05/01/2017

AREA 1: ALPINE, AMADOR, BUTTE, COLUSA, EL DORADO, GLENN,  
LASSEN, MODOC, NEVADA, PLACER, PLUMAS, SACRAMENTO, SHASTA,  
SIERRA, SUTTER, TEHAMA, YOLO AND YUBA COUNTIES

AREA 2: MARIN, NAPA, SISKIYOU, SOLANO, SONOMA AND TRINITY  
COUNTIES

	Rates	Fringes
--	-------	---------

BRICKLAYER

AREA 1.....	\$ 39.66	20.76
AREA 2.....	\$ 42.34	25.83

SPECIALTY PAY:

- (A) Underground work such as tunnel work, sewer work, manholes, catch basins, sewer pipes and telephone conduit shall be paid \$1.25 per hour above the regular rate. Work in direct contact with raw sewage shall receive \$1.25 per hour in addition to the above.
- (B) Operating a saw or grinder shall receive \$1.25 per hour above the regular rate.
- (C) Guniting nozzle person shall receive \$1.25 per hour above the regular rate.

-----  
BRCA0003-008 09/01/2017

	Rates	Fringes
TERRAZZO FINISHER.....	\$ 35.14	16.87
TERRAZZO WORKER/SETTER.....	\$ 44.11	26.36

-----  
BRCA0003-010 04/01/2018

	Rates	Fringes
TILE FINISHER		
Area 1.....	\$ 26.04	13.75
Area 2.....	\$ 26.36	15.97
Area 3.....	\$ 28.56	15.87
Area 4.....	\$ 26.69	15.31
Tile Layer		
Area 1.....	\$ 43.36	16.79
Area 2.....	\$ 43.02	18.19
Area 3.....	\$ 47.77	18.29
Area 4.....	\$ 44.64	18.21

- AREA 1: Butte, Colusa, El Dorado, Glenn, Lassen, Modoc, Nevada, Placer, Plumas, Sacramento, Shasta, Sierra, Sutter, Tehama, Yolo, Yuba
- AREA 2: Alpine, Amador
- AREA 3: Marin, Napa, Solano, Siskiyou
- AREA 4: Sonoma

-----  
BRCA0003-014 08/01/2017

	Rates	Fringes
MARBLE MASON.....	\$ 44.60	26.83

-----  
CARP0034-001 07/01/2018

	Rates	Fringes
Diver		
Assistant Tender, ROV		
Tender/Technician.....	\$ 47.65	32.52
Diver standby.....	\$ 52.61	32.52
Diver Tender.....	\$ 51.82	32.52
Diver wet.....	\$ 97.17	32.52
Manifold Operator (mixed gas).....	\$ 56.82	32.52
Manifold Operator (Standby).....	\$ 51.82	32.52

DEPTH PAY (Surface Diving):  
 050 to 100 ft     \$2.00 per foot

101 to 150 ft \$3.00 per foot
151 to 220 ft \$4.00 per foot

SATURATION DIVING:

The standby rate shall apply until saturation starts. The saturation diving rate applies when divers are under pressure continuously until work task and decompression are complete. The diver rate shall be paid for all saturation hours.

DIVING IN ENCLOSURES:

Where it is necessary for Divers to enter pipes or tunnels, or other enclosures where there is no vertical ascent, the following premium shall be paid: Distance traveled from entrance 26 feet to 300 feet: \$1.00 per foot. When it is necessary for a diver to enter any pipe, tunnel or other enclosure less than 48" in height, the premium will be \$1.00 per foot.

WORK IN COMBINATION OF CLASSIFICATIONS:

Employees working in any combination of classifications within the diving crew (except dive supervisor) in a shift are paid in the classification with the highest rate for that shift.

CARP0034-003 07/01/2017

Table with 2 columns: Rates, Fringes. Row: Piledriver.....\$ 46.65 31.91

CARP0035-001 08/01/2018

AREA 1: MARIN, NAPA, SOLANO & SONOMA

AREA 3: SACRAMENTO, WESTERN EL DORADO (Territory west of an including highway 49 and the territory inside the city limits of Placerville), WESTERN PLACER (Territory west of and including highway 49), & YOLO

AREA 4: ALPINE, BUTTE, COLUSA, EASTERN EL DORADO, GLENN, LASSEN, MODOC, NEVADA, EASTERN PLACER, PLUMAS, SHASTA, SIERRA, SISKIYOU, SUTTER, TEHAMA, TRINITY, & YUBA

Table with 2 columns: Rates, Fringes. Rows for Drywall Installers/Lathers and Drywall Stocker/Scrapper across Areas 1, 3, and 4.

CARP0035-009 07/01/2018

Marin County

Table with 2 columns: Rates, Fringes. Row: CARPENTER Bridge Builder/Highway

Carpenter.....	\$ 48.40	29.32
Hardwood Floorlayer, Shingler, Power Saw Operator, Steel Scaffold & Steel Shoring Erector, Saw Filer.....	\$ 48.55	29.32
Journeyman Carpenter.....	\$ 48.40	29.32
Millwright.....	\$ 48.50	30.91

CARP0035-010 07/01/2017

AREA 1: Marin, Napa, Solano & Sonoma Counties

AREA 2: Monterey, San Benito and Santa Cruz

AREA 3: Alpine, Butte, Colusa, El Dorado, Glenn, Lassen, Modoc,  
Nevada, Placer, Plumas, Sacramento, Shasta, Sierra, Siskiyou,  
Sutter, Tehama, Trinity, Yolo & Yuba counties

	Rates	Fringes
Modular Furniture Installer		
Area 1		
Installer I.....	\$ 24.91	19.63
Installer II.....	\$ 22.18	20.42
Lead Installer.....	\$ 29.06	20.92
Master Installer.....	\$ 33.28	20.92
Area 2		
Installer I.....	\$ 22.96	20.42
Installer II.....	\$ 20.01	20.42
Lead Installer.....	\$ 25.93	20.92
Master Installer.....	\$ 29.56	20.92
Area 3		
Installer I.....	\$ 22.01	20.42
Installer II.....	\$ 19.24	20.42
Lead Installer.....	\$ 24.81	20.92
Master Installer.....	\$ 31.83	20.92

CARP0046-001 07/01/2018

El Dorado (West), Placer (West), Sacramento and Yolo Counties

	Rates	Fringes
Carpenters		
Bridge Builder/Highway		
Carpenter.....	\$ 48.40	29.32
Hardwood Floorlayer, Shingler, Power Saw Operator, Steel Scaffold & Steel Shoring Erector, Saw Filer.....	\$ 42.67	29.32
Journeyman Carpenter.....	\$ 42.52	29.32
Millwright.....	\$ 45.02	30.91

Footnote: Placer County (West) includes territory West of and including Highway 49 and El Dorado County (West) includes territory West of and including Highway 49 and territory inside the city limits of Placerville.

CARP0046-002 07/01/2018

Alpine, Colusa, El Dorado (East), Nevada, Placer (East),



Sierra, Sutter and Yuba Counties

	Rates	Fringes
Carpenters		
Bridge Builder/Highway Carpenter.....	\$ 48.40	29.32
Hardwood Floorlayer, Shingler, Power Saw Operator, Steel Scaffold & Steel Shoring Erector, Saw Filer.....	\$ 41.32	29.32
Journeyman Carpenter.....	\$ 40.17	29.32
Millwright.....	\$ 43.67	30.91

-----  
CARP0152-003 07/01/2018

Amador County

	Rates	Fringes
Carpenters		
Bridge Builder/Highway Carpenter.....	\$ 48.40	29.32
Hardwood Floorlayer, Shingler, Power Saw Operator, Steel Scaffold & Steel Shoring Erector, Saw Filer.....	\$ 41.32	29.32
Journeyman Carpenter.....	\$ 41.17	29.32
Millwright.....	\$ 43.67	30.91

-----  
CARP0180-001 07/01/2018

Solano County

	Rates	Fringes
Carpenters		
Bridge Builder/Highway Carpenter.....	\$ 48.40	29.32
Hardwood Floorlayer, Shingler, Power Saw Operator, Steel Scaffold & Steel Shoring Erector, Saw Filer.....	\$ 48.55	29.32
Journeyman Carpenter.....	\$ 48.40	29.32
Millwright.....	\$ 48.50	30.91

-----  
CARP0751-001 07/01/2018

Napa and Sonoma Counties

	Rates	Fringes
Carpenters		
Bridge Builder/Highway Carpenter.....	\$ 48.40	29.32
Hardwood Floorlayer, Shingler, Power Saw Operator, Steel Scaffold & Steel Shoring Erector, Saw Filer.....	\$ 48.55	29.32
Journeyman Carpenter.....	\$ 48.50	29.32

Millwright.....\$ 48.50 30.91

-----  
CARP1599-001 07/01/2018

Butte, Glenn, Lassen, Modoc, Plumas, Shasta, Siskiyou, Tehama  
and Trinity Counties

Rates Fringes

Carpenters

Bridge Builder/Highway  
Carpenter.....\$ 48.40 29.32  
Hardwood Floorlayer,  
Shingler, Power Saw  
Operator, Steel Scaffold &  
Steel Shoring Erector, Saw  
Filer.....\$ 41.32 29.32  
Journeyman Carpenter.....\$ 41.17 29.32  
Millwright.....\$ 43.67 30.91

-----  
ELEC0180-001 06/01/2017

NAPA AND SOLANO COUNTIES

Rates Fringes

CABLE SPLICER.....\$ 50.97 3%+20.13  
ELECTRICIAN.....\$ 47.31 23.05

-----  
\* ELEC0180-003 12/01/2018

NAPA AND SOLANO COUNTIES

Rates Fringes

Sound & Communications  
Installer.....\$ 38.42 19.70  
Technician.....\$ 44.18 19.88

SCOPE OF WORK INCLUDES-

SOUND & VOICE TRANSMISSION (Music, Intercom, Nurse Call,  
Telephone); FIRE ALARM SYSTEMS [excluding fire alarm work  
when installed in raceways (including wire and cable  
pulling) and when performed on new or major remodel  
building projects or jobs],  
TELEVISION & VIDEO SYSTEMS, SECURITY SYSTEMS, COMMUNICATIONS  
SYSTEMS that transmit or receive information and/or control  
systems that are intrinsic to the above.

EXCLUDES-

Excludes all other data systems or multiple systems which  
include control function or power supply; excludes  
installation of raceway systems, line voltage work,  
industrial work, life-safety systems (all buildings having  
floors located more than 75' above the lowest floor level  
having building access); excludes energy management  
systems.

-----  
ELEC0340-002 02/01/2018

ALPINE, AMADOR, BUTTE, COLUSA, EL DORADO, GLENN, LASSEN,  
NEVADA, PLACER, PLUMAS, SACRAMENTO, TRINITY, YOLO, YUBA COUNTIES

## Rates Fringes

## Communications System

## Sound &amp; Communications

Installer.....	\$ 29.35	3%+15.35
----------------	----------	----------

## Sound &amp; Communications

Technician.....	\$ 33.75	3%+15.35
-----------------	----------	----------

## SCOPE OF WORK

Includes the installation testing, service and maintenance, of the following systems which utilize the transmission and/or transference of voice, sound, vision and digital for commercial, education, security and entertainment purposes for the following TV monitoring and surveillance, background-foreground music, intercom and telephone interconnect, inventory control systems, microwave transmission, multi-media, multiplex, nurse call system, radio page, school intercom and sound, burglar alarms, and low voltage master clock systems.

## A. SOUND AND VOICE TRANSMISSION/TRANSFERENCE SYSTEMS

Background foreground music Intercom and telephone interconnect systems, Telephone systems, Nurse call systems, Radio page systems, School intercom and sound systems, Burglar alarm systems, Low voltage master clock systems, Multi-media/multiplex systems, Sound and musical entertainment systems, RF systems, Antennas and Wave Guide.

## B. FIRE ALARM SYSTEMS

Installation, wire pulling and testing

C. TELEVISION AND VIDEO SYSTEMS Television monitoring and surveillance systems, Video security systems, Video entertainment systems, Video educational systems, Microwave transmission systems, CATV and CCTV

## D. SECURITY SYSTEMS

Perimeter security systems  
Vibration sensor systems Card access systems Access control systems Sonar/infrared monitoring equipment

## E. COMMUNICATIONS SYSTEMS THAT TRANSMIT OR RECEIVE

INFORMATION AND/OR CONTROL SYSTEMS THAT ARE INTRINSIC TO THE ABOVE LISTED SYSTEMS SCADA (Supervisory Control and Data Acquisition) PCM (Pulse Code Modulation)

Inventory Control Systems Digital Data Systems

Broadband and Baseband and Carriers Point of Sale Systems VSAT Data Systems Data Communication

Systems RF and Remote Control Systems Fiber Optic Data Systems

WORK EXCLUDED Raceway systems are not covered (excluding Ladder-Rack for the purpose of the above listed systems). Chases and/or nipples (not to exceed 10 feet)

may be installed on open wiring systems. Energy management systems. SCADA (Supervisory Control and Data Acquisition)

when not intrinsic to the above listed systems (in the scope). Fire alarm systems when installed in raceways

(including wire and cable pulling) shall be performed at the electrician wage rate, when either of the following two (2) conditions apply:

1. The project involves new or major remodel building trades construction.

2. The conductors for the fire alarm system are installed in conduit.

-----  
ELEC0340-003 08/01/2018

ALPINE (West of Sierra Mt. Watershed), AMADOR, BUTTE, COLUSA,  
EL DORADO (West of Sierra Mt. Watershed), GLENN, LASSEN, NEVADA  
(West of Sierra Mt. Watershed), PLACER, PLUMAS, SACRAMENTO,  
SHASTA, SIERRA (West of Sierra Mt. Watershed), SUTTER, TEHAMA,  
TRINITY, YOLO & YUBA COUNTIES

Rates Fringes

ELECTRICIAN

Remaining area.....	\$ 40.06	28.54
Sierra Army Depot, Herlong..	\$ 48.83	18.54
Tunnel work.....	\$ 41.01	18.54

CABLE SPLICER: Receives 110% of the Electrician basic hourly rate.

-----  
ELEC0401-005 07/01/2018

ALPINE (east of the main watershed divide), EL DORADO (east of the main watershed divide), NEVADA (east of the main watershed), PLACER (east of the main watershed divide) and SIERRA (east of the main watershed divide) COUNTIES:

Rates Fringes

ELECTRICIAN.....	\$ 40.50	17.38
------------------	----------	-------

-----  
ELEC0551-004 06/01/2018

MARIN AND SONOMA COUNTIES

Rates Fringes

ELECTRICIAN.....	\$ 48.40	22.66
------------------	----------	-------

-----  
ELEC0551-005 12/01/2018

MARIN & SONOMA COUNTIES

Rates Fringes

Sound & Communications

Installer.....	\$ 38.42	20.11
Technician.....	\$ 44.18	20.29

SCOPE OF WORK INCLUDES-

SOUND & VOICE TRANSMISSION (Music, Intercom, Nurse Call, Telephone); FIRE ALARM SYSTEMS [excluding fire alarm work when installed in raceways (including wire and cable pulling) and when performed on new or major remodel building projects or jobs], TELEVISION & VIDEO SYSTEMS, SECURITY SYSTEMS, COMMUNICATIONS SYSTEMS that transmit or receive information and/or control systems that are intrinsic to the above.

EXCLUDES-

Excludes all other data systems or multiple systems which include control function or power supply; excludes installation of raceway systems, line voltage work,

industrial work, life-safety systems (all buildings having floors located more than 75' above the lowest floor level having building access); excludes energy management systems.

-----  
ELEC0659-006 01/01/2019

DEL NORTE, MODOC and SISKIYOU COUNTIES

	Rates	Fringes
ELECTRICIAN.....	\$ 35.19	16.80

-----  
ELEC0659-008 02/01/2018

DEL NORTE, MODOC & SISKIYOU COUNTIES

	Rates	Fringes
Line Construction		
(1) Cable Splicer.....	\$ 57.94	18.27
(2) Lineman, Pole Sprayer, Heavy Line Equipment Man....	\$ 51.73	18.02
(3) Tree Trimmer.....	\$ 31.10	11.32
(4) Line Equipment Man.....	\$ 51.73	18.02
(5) Powdermen, Jackhammermen.....	\$ 33.80	13.35
(6) Groundman.....	\$ 33.11	13.17

-----  
ELEC1245-004 01/01/2019

ALL COUNTIES EXCEPT DEL NORTE, MODOC & SISKIYOU

	Rates	Fringes
LINE CONSTRUCTION		
(1) Lineman; Cable splicer..	\$ 56.79	17.41
(2) Equipment specialist (operates crawler tractors, commercial motor vehicles, backhoes, trenchers, cranes (50 tons and below), overhead & underground distribution line equipment).....	\$ 45.36	16.24
(3) Groundman.....	\$ 34.68	15.86
(4) Powderman.....	\$ 49.55	3%+17.65

HOLIDAYS: New Year's Day, M.L. King Day, Memorial Day, Independence Day, Labor Day, Veterans Day, Thanksgiving Day and day after Thanksgiving, Christmas Day

-----  
ELEV0008-001 01/01/2019

	Rates	Fringes
ELEVATOR MECHANIC.....	\$ 67.56	34.125+a+b

FOOTNOTE:

PAID VACATION: Employer contributes 8% of regular hourly rate as vacation pay credit for employees with more than 5 years of service, and 6% for 6 months to 5 years of service.  
PAID HOLIDAYS: New Years Day, Memorial Day, Independence Day,

Labor Day, Veterans Day, Thanksgiving Day, Friday after Thanksgiving, and Christmas Day.

-----  
ENGI0003-008 07/01/2017

	Rates	Fringes
Dredging: (DREDGING: CLAMSHELL & DIPPER DREDGING; HYDRAULIC SUCTION DREDGING:)		
AREA 1:		
(1) Leverman.....	\$ 44.77	31.25
(2) Dredge Dozer; Heavy duty repairman.....	\$ 39.81	31.25
(3) Booster Pump Operator; Deck Engineer; Deck mate; Dredge Tender; Winch Operator.....	\$ 38.69	31.25
(4) Bargeman; Deckhand; Fireman; Leveehand; Oiler..	\$ 35.39	31.25
AREA 2:		
(1) Leverman.....	\$ 46.77	31.25
(2) Dredge Dozer; Heavy duty repairman.....	\$ 41.81	31.25
(3) Booster Pump Operator; Deck Engineer; Deck mate; Dredge Tender; Winch Operator.....	\$ 40.69	31.25
(4) Bargeman; Deckhand; Fireman; Leveehand; Oiler..	\$ 37.39	31.25

AREA DESCRIPTIONS

AREA 1: ALAMEDA, BUTTE, CONTRA COSTA, KINGS, MARIN, MERCED, NAPA, SACRAMENTO, SAN BENITO, SAN FRANCISCO, SAN JOAQUIN, SAN MATEO, SANTA CLARA, SANTA CRUZ, SOLANO, STANISLAUS, SUTTER, YOLO, AND YUBA COUNTIES

AREA 2: MODOC COUNTY

THE REMAINING COUNTIES ARE SPLIT BETWEEN AREA 1 AND AREA 2 AS NOTED BELOW:

ALPINE COUNTY:

Area 1: Northernmost part  
Area 2: Remainder

CALAVERAS COUNTY:

Area 1: Remainder  
Area 2: Eastern part

COLUSA COUNTY:

Area 1: Eastern part  
Area 2: Remainder

ELDORADO COUNTY:

Area 1: North Central part  
Area 2: Remainder

FRESNO COUNTY:

Area 1: Remainder  
Area 2: Eastern part

**GLENN COUNTY:**

Area 1: Eastern part

Area 2: Remainder

**LASSEN COUNTY:**Area 1: Western part along the Southern portion of border  
with Shasta County

Area 2: Remainder

**MADERA COUNTY:**

Area 1: Except Eastern part

Area 2: Eastern part

**MARIPOSA COUNTY**

Area 1: Except Eastern part

Area 2: Eastern part

**MONTERREY COUNTY**

Area 1: Except Southwestern part

Area 2: Southwestern part

**NEVADA COUNTY:**Area 1: All but the Northern portion along the border of  
Sierra County

Area 2: Remainder

**PLACER COUNTY:**

Area 1: All but the Central portion

Area 2: Remainder

**PLUMAS COUNTY:**

Area 1: Western portion

Area 2: Remainder

**SHASTA COUNTY:**

Area 1: All but the Northeastern corner

Area 2: Remainder

**SIERRA COUNTY:**

Area 1: Western part

Area 2: Remainder

**SISKIYOU COUNTY:**

Area 1: Central part

Area 2: Remainder

**SONOMA COUNTY:**

Area 1: All but the Northwestern corner

Area 2: Remainder

**TEHAMA COUNTY:**Area 1: All but the Western border with Mendocino & Trinity  
Counties

Area 2: Remainder

**TRINITY COUNTY:**Area 1: East Central part and the Northeastern border with  
Shasta County

Area 2: Remainder

**TUOLUMNE COUNTY:**

Area 1: Except Eastern part

Area 2: Eastern part

-----  
ENGI0003-018 06/26/2017

"AREA 1" WAGE RATES ARE LISTED BELOW

"AREA 2" RECEIVES AN ADDITIONAL \$2.00 PER HOUR ABOVE AREA 1 RATES.

SEE AREA DEFINITIONS BELOW

	Rates	Fringes
OPERATOR: Power Equipment (AREA 1:)		
GROUP 1.....	\$ 44.67	30.39
GROUP 2.....	\$ 43.14	30.39
GROUP 3.....	\$ 41.66	30.39
GROUP 4.....	\$ 40.28	30.39
GROUP 5.....	\$ 39.01	30.39
GROUP 6.....	\$ 37.69	30.39
GROUP 7.....	\$ 36.55	30.39
GROUP 8.....	\$ 35.41	30.39
GROUP 8-A.....	\$ 33.20	30.39
OPERATOR: Power Equipment (Cranes and Attachments - AREA 1:)		
GROUP 1		
Cranes.....	\$ 46.30	30.39
Oiler.....	\$ 36.63	30.39
Truck crane oiler.....	\$ 39.20	30.39
GROUP 2		
Cranes.....	\$ 43.79	30.39
Oiler.....	\$ 36.36	30.39
Truck crane oiler.....	\$ 38.98	30.39
GROUP 3		
Cranes.....	\$ 42.05	30.39
Hydraulic.....	\$ 38.32	30.39
Oiler.....	\$ 36.14	30.39
Truck Crane Oiler.....	\$ 38.71	30.39
GROUP 4		
Cranes.....	\$ 39.01	30.39
OPERATOR: Power Equipment (Piledriving - AREA 1:)		
GROUP 1		
Lifting devices.....	\$ 45.89	30.39
Oiler.....	\$ 36.63	30.39
Truck crane oiler.....	\$ 39.20	30.39
GROUP 2		
Lifting devices.....	\$ 44.07	30.39
Oiler.....	\$ 36.36	30.39
Truck Crane Oiler.....	\$ 38.98	30.39
GROUP 3		
Lifting devices.....	\$ 42.39	30.39
Oiler.....	\$ 36.14	30.39
Truck Crane Oiler.....	\$ 38.71	30.39
GROUP 4		
Lifting devices.....	\$ 40.62	30.39
GROUP 5		
Lifting devices.....	\$ 39.32	30.39
GROUP 6		
Lifting devices.....	\$ 37.98	30.39
OPERATOR: Power Equipment (Steel Erection - AREA 1:)		
GROUP 1		



Cranes.....	\$ 46.30	30.39
Oiler.....	\$ 36.63	30.39
Truck Crane Oiler.....	\$ 39.20	30.39
GROUP 2		
Cranes.....	\$ 43.79	30.39
Oiler.....	\$ 36.36	30.39
Truck Crane Oiler.....	\$ 38.98	30.39
GROUP 3		
Cranes.....	\$ 42.05	30.39
Hydraulic.....	\$ 38.32	30.39
Oiler.....	\$ 36.14	30.39
Truck Crane Oiler.....	\$ 38.71	30.39
GROUP 4		
Cranes.....	\$ 39.01	30.39
GROUP 5		
Cranes.....	\$ 35.13	30.39
OPERATOR: Power Equipment		
(Tunnel and Underground Work		
- AREA 1:)		
SHAFTS, STOPES, RAISES:		
GROUP 1.....	\$ 40.77	30.39
GROUP 1-A.....	\$ 43.24	30.39
GROUP 2.....	\$ 39.51	30.39
GROUP 3.....	\$ 38.18	30.39
GROUP 4.....	\$ 37.04	30.39
GROUP 5.....	\$ 35.90	30.39
UNDERGROUND:		
GROUP 1.....	\$ 40.67	30.39
GROUP 1-A.....	\$ 43.14	30.39
GROUP 2.....	\$ 39.41	30.39
GROUP 3.....	\$ 38.08	30.39
GROUP 4.....	\$ 36.94	30.39
GROUP 5.....	\$ 35.80	30.39

FOOTNOTE: Work suspended by ropes or cables, or work on a Yo-Yo Cat: \$.60 per hour additional.

POWER EQUIPMENT OPERATOR CLASSIFICATIONS

GROUP 1: Operator of helicopter (when used in erection work); Hydraulic excavator, 7 cu. yds. and over; Power shovels, over 7 cu. yds.

GROUP 2: Highline cableway; Hydraulic excavator, 3-1/2 cu. yds. up to 7 cu. yds.; Licensed construction work boat operator, on site; Power blade operator (finish); Power shovels, over 1 cu. yd. up to and including 7 cu. yds. m.r.c.

GROUP 3: Asphalt milling machine; Cable backhoe; Combination backhoe and loader over 3/4 cu. yds.; Continuous flight tie back machine assistant to engineer or mechanic; Crane mounted continuous flight tie back machine, tonnage to apply; Crane mounted drill attachment, tonnage to apply; Dozer, slope brd; Gradall; Hydraulic excavator, up to 3 1/2 cu. yds.; Loader 4 cu. yds. and over; Long reach excavator; Multiple engine scraper (when used as push pull); Power shovels, up to and including 1 cu. yd.; Pre-stress wire wrapping machine; Side boom cat, 572 or larger; Track loader 4 cu. yds. and over; Wheel excavator (up to and including 750 cu. yds. per hour)

GROUP 4: Asphalt plant engineer/box person; Chicago boom; Combination backhoe and loader up to and including 3/4 cu.

yd.; Concrete batch plant (wet or dry); Dozer and/or push cat; Pull- type elevating loader; Gradesetter, grade checker (GPS, mechanical or otherwise); Grooving and grinding machine; Heading shield operator; Heavy-duty drilling equipment, Hughes, LDH, Watson 3000 or similar; Heavy-duty repairperson and/or welder; Lime spreader; Loader under 4 cu. yds.; Lubrication and service engineer (mobile and grease rack); Mechanical finishers or spreader machine (asphalt, Barber-Greene and similar); Miller Formless M-9000 slope paver or similar; Portable crushing and screening plants; Power blade support; Roller operator, asphalt; Rubber-tired scraper, self-loading (paddle-wheels, etc.); Rubber-tired earthmoving equipment (scrapers); Slip form paver (concrete); Small tractor with drag; Soil stabilizer (P & H or equal); Spider plow and spider puller; Tubex pile rig; Unlicensed construction work boat operator, on site; Timber skidder; Track loader up to 4 yds.; Tractor-drawn scraper; Tractor, compressor drill combination; Welder; Woods-Mixer (and other similar Pugmill equipment)

GROUP 5: Cast-in-place pipe laying machine; Combination slusher and motor operator; Concrete conveyor or concrete pump, truck or equipment mounted; Concrete conveyor, building site; Concrete pump or pumpcrete gun; Drilling equipment, Watson 2000, Texoma 700 or similar; Drilling and boring machinery, horizontal (not to apply to waterliners, wagon drills or jackhammers); Concrete mixer/all; Person and/or material hoist; Mechanical finishers (concrete) (Clary, Johnson, Bidwell Bridge Deck or similar types); Mechanical burm, curb and/or curb and gutter machine, concrete or asphalt); Mine or shaft hoist; Portable crusher; Power jumbo operator (setting slip-forms, etc., in tunnels); Screed (automatic or manual); Self-propelled compactor with dozer; Tractor with boom D6 or smaller; Trenching machine, maximum digging capacity over 5 ft. depth; Vermeer T-600B rock cutter or similar

GROUP 6: Armor-Coater (or similar); Ballast jack tamper; Boom- type backfilling machine; Assistant plant engineer; Bridge and/or gantry crane; Chemical grouting machine, truck-mounted; Chip spreading machine operator; Concrete saw (self-propelled unit on streets, highways, airports and canals); Deck engineer; Drilling equipment Texoma 600, Hughes 200 Series or similar up to and including 30 ft. m.r.c.; Drill doctor; Helicopter radio operator; Hydro-hammer or similar; Line master; Skidsteer loader, Bobcat larger than 743 series or similar (with attachments); Locomotive; Lull hi-lift or similar; Oiler, truck mounted equipment; Pavement breaker, truck-mounted, with compressor combination; Paving fabric installation and/or laying machine; Pipe bending machine (pipelines only); Pipe wrapping machine (tractor propelled and supported); Screed (except asphaltic concrete paving); Self-propelled pipeline wrapping machine; Tractor; Self-loading chipper; Concrete barrier moving machine

GROUP 7: Ballast regulator; Boom truck or dual-purpose A-frame truck, non-rotating - under 15 tons; Cary lift or similar; Combination slurry mixer and/or cleaner; Drilling equipment, 20 ft. and under m.r.c.; Firetender (hot plant); Grouting machine operator; Highline cableway signalperson; Stationary belt loader (Kolman or similar); Lift slab machine (Vagtborg and similar types); Maginnes internal full slab vibrator; Material hoist (1 drum); Mechanical

trench shield; Pavement breaker with or without compressor combination); Pipe cleaning machine (tractor propelled and supported); Post driver; Roller (except asphalt); Chip Seal; Self-propelled automatically applied concrete curing machine (on streets, highways, airports and canals); Self-propelled compactor (without dozer); Signaller; Slip-form pumps (lifting device for concrete forms); Tie spacer; Tower mobile; Trenching machine, maximum digging capacity up to and including 5 ft. depth; Truck- type loader

GROUP 8: Bit sharpener; Boiler tender; Box operator; Brakeperson; Combination mixer and compressor (shotcrete/gunite); Compressor operator; Deckhand; Fire tender; Forklift (under 20 ft.); Generator; Gunite/shotcrete equipment operator; Hydraulic monitor; Ken seal machine (or similar); Mixermobile; Oiler; Pump operator; Refrigeration plant; Reservoir-debris tug (self-propelled floating); Ross Carrier (construction site); Rotomist operator; Self-propelled tape machine; Shuttlecar; Self-propelled power sweeper operator (includes vacuum sweeper); Slusher operator; Surface heater; Switchperson; Tar pot firetender; Tugger hoist, single drum; Vacuum cooling plant; Welding machine (powered other than by electricity)

GROUP 8-A: Elevator operator; Skidsteer loader-Bobcat 743 series or smaller, and similar (without attachments); Mini excavator under 25 H.P. (backhoe-trencher); Tub grinder wood chipper

-----

#### ALL CRANES AND ATTACHMENTS

GROUP 1: Clamshell and dragline over 7 cu. yds.; Crane, over 100 tons; Derrick, over 100 tons; Derrick barge pedestal-mounted, over 100 tons; Self-propelled boom-type lifting device, over 100 tons

GROUP 2: Clamshell and dragline over 1 cu. yd. up to and including 7 cu. yds.; Crane, over 45 tons up to and including 100 tons; Derrick barge, 100 tons and under; Self-propelled boom-type lifting device, over 45 tons; Tower crane

GROUP 3: Clamshell and dragline up to and including 1 cu. yd.; Cranes 45 tons and under; Self-propelled boom-type lifting device 45 tons and under;

GROUP 4: Boom Truck or dual purpose A-frame truck, non-rotating over 15 tons; Truck-mounted rotating telescopic boom type lifting device, Manitex or similar (boom truck) over 15 tons; Truck-mounted rotating telescopic boom type lifting device, Manitex or similar (boom truck) - under 15 tons;

-----

#### PILEDRIVERS

GROUP 1: Derrick barge pedestal mounted over 100 tons; Clamshell over 7 cu. yds.; Self-propelled boom-type lifting device over 100 tons; Truck crane or crawler, land or barge mounted over 100 tons

GROUP 2: Derrick barge pedestal mounted 45 tons to and including 100 tons; Clamshell up to and including 7 cu. yds.; Self-propelled boom-type lifting device over 45 tons; Truck crane or crawler, land or barge mounted, over 45 tons up to and including 100 tons; Fundex F-12 hydraulic pile rig

GROUP 3: Derrick barge pedestal mounted under 45 tons; Self-propelled boom-type lifting device 45 tons and under; Skid/scow piledriver, any tonnage; Truck crane or crawler, land or barge mounted 45 tons and under

GROUP 4: Assistant operator in lieu of assistant to engineer; Forklift, 10 tons and over; Heavy-duty repairperson/welder

GROUP 5: Deck engineer

GROUP 6: Deckhand; Fire tender

-----

STEEL ERECTORS

GROUP 1: Crane over 100 tons; Derrick over 100 tons; Self-propelled boom-type lifting device over 100 tons

GROUP 2: Crane over 45 tons to 100 tons; Derrick under 100 tons; Self-propelled boom-type lifting device over 45 tons to 100 tons; Tower crane

GROUP 3: Crane, 45 tons and under; Self-propelled boom-type lifting device, 45 tons and under

GROUP 4: Chicago boom; Forklift, 10 tons and over; Heavy-duty repair person/welder

GROUP 5: Boom cat

-----  
--

TUNNEL AND UNDERGROUND WORK

GROUP 1-A: Tunnel bore machine operator, 20' diameter or more

GROUP 1: Heading shield operator; Heavy-duty repairperson; Mucking machine (rubber tired, rail or track type); Raised bore operator (tunnels); Tunnel mole bore operator

GROUP 2: Combination slusher and motor operator; Concrete pump or pumpcrete gun; Power jumbo operator

GROUP 3: Drill doctor; Mine or shaft hoist

GROUP 4: Combination slurry mixer cleaner; Grouting Machine operator; Motorman

GROUP 5: Bit Sharpener; Brakeman; Combination mixer and compressor (gunite); Compressor operator; Oiler; Pump operator; Slusher operator

-----

AREA DESCRIPTIONS:

POWER EQUIPMENT OPERATORS, CRANES AND ATTACHMENTS, TUNNEL AND

UNDERGROUND [These areas do not apply to Piledrivers and Steel Erectors]

AREA 1: ALPINE, AMADOR, BUTTE, COLUSA, EL DORADO, GLENN, LASSEN, MARIN, NAPA, NEVADA, PLACER, PLUMAS, SACRAMENTO, SHASTA, SIERRA, SISKIYOU, SOLANO, SONOMA, SUTTER, TEHAMA, TRINITY, YOLO, YUBA

AREA 2 - MODOC COUNTY

THE REMAINING COUNTIES ARE SPLIT BETWEEN AREA 1 AND AREA 2 AS NOTED BELOW:

ALPINE COUNTY:

Area 1: Northernmost part

Area 2: Remainder

COLUSA COUNTY:

Area 1: Eastern part

Area 2: Remainder

DEL NORTE COUNTY:

Area 1: Extreme Southwestern corner

Area 2: Remainder

ELDORADO COUNTY:

Area 1: North Central part

Area 2: Remainder

GLENN COUNTY:

Area 1: Eastern part

Area 2: Remainder

LASSEN COUNTY:

Area 1: Western part along the Southern portion of border with Shasta County

Area 2: Remainder

NEVADA COUNTY:

Area 1: All but the Northern portion along the border of Sierra County

Area 2: Remainder

PLACER COUNTY:

Area 1: All but the Central portion

Area 2: Remainder

PLUMAS COUNTY:

Area 1: Western portion

Area 2: Remainder

SHASTA COUNTY:

Area 1: All but the Northeastern corner

Area 2: Remainder

SIERRA COUNTY:

Area 1: Western part

Area 2: Remainder

SISKIYOU COUNTY:

Area 1: Central part

Area 2: Remainder

SONOMA COUNTY:

Area 1: All but the Northwestern corner

Area 2: Reaminder

TEHAMA COUNTY:

Area 1: All but the Western border with mendocino & Trinity Counties

Area 2: Remainder

TRINITY COUNTY:

Area 1: East Central part and the Northeaster border with Shasta County

Area 2: Remainder

-----  
ENGI0003-019 07/26/2017

SEE AREA DESCRIPTIONS BELOW

	Rates	Fringes
OPERATOR: Power Equipment (LANDSCAPE WORK ONLY)		
GROUP 1		
AREA 1.....	\$ 34.05	28.73
AREA 2.....	\$ 36.05	28.73
GROUP 2		
AREA 1.....	\$ 30.45	28.73
AREA 2.....	\$ 32.45	28.73
GROUP 3		
AREA 1.....	\$ 25.84	28.73
AREA 2.....	\$ 27.84	28.73

GROUP DESCRIPTIONS:

GROUP 1: Landscape Finish Grade Operator: All finish grade work regardless of equipment used, and all equipment with a rating more than 65 HP.

GROUP 2: Landscape Operator up to 65 HP: All equipment with a manufacturer's rating of 65 HP or less except equipment covered by Group 1 or Group 3. The following equipment shall be included except when used for finish work as long as manufacturer's rating is 65 HP or less: A-Frame and Winch Truck, Backhoe, Forklift, Hydragraphic Seeder Machine, Roller, Rubber-Tired and Track Earthmoving Equipment, Skiploader, Straw Blowers, and Trencher 31 HP up to 65 HP.

GROUP 3: Landscae Utility Operator: Small Rubber-Tired Tractor, Trencher Under 31 HP.

AREA DESCRIPTIONS:

AREA 1: ALAMEDA, BUTTE, CONTRA COSTA, KINGS, MARIN, MERCED, NAPA, SACRAMENTO, SAN BENITO, SAN FRANCISCO, SAN JOAQUIN, SAN MATEO, SANTA CLARA, SANTA CRUZ, SOLANO, STANISLAUS, SUTTER, YOLO, AND YUBA COUNTIES

AREA 2 - MODOC COUNTY

THE REMAINING COUNTIES ARE SPLIT BETWEEN AREA 1 AND AREA 2 AS NOTED BELOW:

ALPINE COUNTY:

Area 1: Northernmost part  
Area 2: Remainder

6/5/2019

**CALAVERAS COUNTY:**

Area 1: Except Eastern part

Area 2: Eastern part

**COLUSA COUNTY:**

Area 1: Eastern part

Area 2: Remainder

**DEL NORTE COUNTY:**

Area 1: Extreme Southwestern corner

Area 2: Remainder

**ELDORADO COUNTY:**

Area 1: North Central part

Area 2: Remainder

**FRESNO COUNTY**

Area 1: Except Eastern part

Area 2: Eastern part

**GLENN COUNTY:**

Area 1: Eastern part

Area 2: Remainder

**HUMBOLDT COUNTY:**

Area 1: Except Eastern and Southwestern parts

Area 2: Remainder

**LAKE COUNTY:**

Area 1: Southern part

Area 2: Remainder

**LASSEN COUNTY:**Area 1: Western part along the Southern portion of border  
with Shasta County

Area 2: Remainder

**MADERA COUNTY**

Area 1: Remainder

Area 2: Eastern part

**MARIPOSA COUNTY**

Area 1: Remainder

Area 2: Eastern part

**MENDOCINO COUNTY:**

Area 1: Central and Southeastern parts

Area 2: Remainder

**MONTEREY COUNTY**

Area 1: Remainder

Area 2: Southwestern part

**NEVADA COUNTY:**Area 1: All but the Northern portion along the border of  
Sierra County

Area 2: Remainder

**PLACER COUNTY:**

Area 1: All but the Central portion

Area 2: Remainder

**PLUMAS COUNTY:**

Area 1: Western portion

Area 2: Remainder

SHASTA COUNTY:

Area 1: All but the Northeastern corner

Area 2: Remainder

SIERRA COUNTY:

Area 1: Western part

Area 2: Remainder

SISKIYOU COUNTY:

Area 1: Central part

Area 2: Remainder

SONOMA COUNTY:

Area 1: All but the Northwestern corner

Area 2: Reaminder

TEHAMA COUNTY:

Area 1: All but the Western border with mendocino & Trinity Counties

Area 2: Remainder

TRINITY COUNTY:

Area 1: East Central part and the Northeaster border with Shasta County

Area 2: Remainder

TULARE COUNTY;

Area 1: Remainder

Area 2: Eastern part

TUOLUMNE COUNTY:

Area 1: Remainder

Area 2: Eastern Part

-----  
IRON0377-002 01/01/2019

Rates Fringes

Ironworkers:

Fence Erector.....	\$ 32.58	23.41
Ornamental, Reinforcing and Structural.....	\$ 39.00	32.05

PREMIUM PAY:

\$6.00 additional per hour at the following locations:

China Lake Naval Test Station, Chocolate Mountains Naval Reserve-Niland, Edwards AFB, Fort Irwin Military Station, Fort Irwin Training Center-Goldstone, San Clemente Island, San Nicholas Island, Susanville Federal Prison, 29 Palms - Marine Corps, U.S. Marine Base - Barstow, U.S. Naval Air Facility - Sealey, Vandenberg AFB

\$4.00 additional per hour at the following locations:

Army Defense Language Institute - Monterey, Fallon Air Base, Naval Post Graduate School - Monterey, Yermo Marine Corps Logistics Center

\$2.00 additional per hour at the following locations:

Port Hueneme, Port Mugu, U.S. Coast Guard Station - Two Rock



-----  
LAB00067-001 12/01/2018

AREA "A" - MARIN COUNTY

AREA "B" - ALPINE, AMADOR, BUTTE COLUSA EL DORADO, GLENN, LASSEN, MODOC, NAPA, NEVADA, PLACER, PLUMAS, SACRAMENTO, SHASTA, SIERRA, SISKIYOU, SOLANO, SONOMA, SUTTER, TEHAMA, TRINITY, YOLO, AND YUBA COUNTIES

	Rates	Fringes
Asbestos Removal Laborer.....	\$ 24.00	11.13
LABORER (Lead Removal)		
Marin County.....	\$ 31.81	22.71
Remaining Counties.....	\$ 30.81	22.71

-----  
LAB00067-005 06/27/2017

AREA "A" - ALAMEDA, CONTRA COSTA, MARIN, SAN FRANCISCO, SAN MATEO AND SANTA CLARA COUNTIES

AREA "B" - ALPINE, AMADOR, BUTTE, CALAVERAS, COLUSA, DEL NORTE, EL DORADO, FRESNO, GLENN, HUMBOLDT, KINGS, LAKE, LASSEN, MADERA, MARIPOSA, MENDOCINO, MERCED, MODOC, MONTEREY, NAPA, NEVADA, PLACER, PLUMAS, SANCREMENTO, SAN BENITO, SAN JOAQUIN, SANTA CRUZ, SIERRA, SHASTA, SISKIYOU, SOLANO, SONOMA, STANISLAUS, TEHAMA, TRINITY, TULARE, TUOLUMNE, YOLO AND YUBA COUNTIES

	Rates	Fringes
LABORER (TRAFFIC CONTROL/LANE CLOSURE)		
Escort Driver, Flag Person		
Area A.....	\$ 29.54	22.17
Area B.....	\$ 28.54	22.17
Traffic Control Person I		
Area A.....	\$ 29.84	22.17
Area B.....	\$ 28.84	22.17
Traffic Control Person II		
Area A.....	\$ 27.34	22.17
Area B.....	\$ 26.34	22.17

TRAFFIC CONTROL PERSON I: Layout of traffic control, crash cushions, construction area and roadside signage.

TRAFFIC CONTROL PERSON II: Installation and removal of temporary/permanent signs, markers, delineators and crash cushions.

-----  
LAB00185-002 07/01/2018

ALPINE, AMADOR, BUTTE, COLUSA, EL DORADO, GLENN, LASSEN, MODOC, NEVADA, PLACER, PLUMAS, SACRAMENTO, SHASTA, SIERRA, SISKIYOU, SUTTER, TEHAMA, TRINITY, YOLO AND YUBA COUNTIES

Rates                      Fringes

LABORER

Mason Tender-Brick.....\$ 31.20 22.20

LABO0185-005 06/25/2018

ALPINE, AMADOR, BUTTE, COLUSA, EL DORADO, GLENN, LASSEN, MODOC, NEVADA, PLACER, PLUMAS, SACRAMENTO, SHASTA, SIERRA, SISKIYOU, SUTTER, TEHAMA, TRINITY, YOLO AND YUBA COUNTIES

Rates Fringes

Tunnel and Shaft Laborers:

GROUP 1.....\$ 37.82 24.11
GROUP 2.....\$ 37.59 24.11
GROUP 3.....\$ 37.34 24.11
GROUP 4.....\$ 36.89 24.11
GROUP 5.....\$ 36.35 24.11
Shotcrete Specialist.....\$ 38.34 24.11

TUNNEL AND SHAFT CLASSIFICATIONS

GROUP 1: Diamond driller; Groundmen; Gunite and shotcrete nozzlemen

GROUP 2: Rodmen; Shaft work & raise (below actual or excavated ground level)

GROUP 3: Bit grinder; Blaster, driller, powdermen, heading; Cherry pickermen - where car is lifted; Concrete finisher in tunnel; Concrete screedman; Grout pumpman and potman; Gunite & shotcrete gunman & potman; Headermen; High pressure nozzleleman; Miner - tunnel, including top and bottom man on shaft and raise work; Nipper; Nozzleman on slick line; Sandblaster - potman, Robotic Shotcrete Placer, Segment Erector, Tunnel Muck Hauler, Steel Form raiser and setter; Timberman, retimberman (wood or steel or substitute materials therefore); Tugger (for tunnel laborer work); Cable tender; Chuck tender; Powderman - primer house

GROUP 4: Vibrator operator, pavement breaker; Bull gang - muckers, trackmen; Concrete crew - includes rodding and spreading, Dumpmen (any method)

GROUP 5: Grout crew; Reboundman; Swamper/ Brakeman

LABO0185-006 06/25/2018

ALPINE, AMADOR, BUTTE, COLUSA, EL DORADO, GLENN, LASSEN, MODOC, NEVADA, PLACER, PLUMAS, SACRAMENTO, SHIASTA, SIERRA, SISKIYOU, SUTTER, TEHAMA, TRINITY, YOLO, YUBA COUNTIES

Rates Fringes

LABORER (CONSTRUCTION CRAFT

LABORERS - AREA B:)

Construction Specialist
Group.....\$ 30.49 23.20
GROUP 1.....\$ 29.79 23.20
GROUP 1-a.....\$ 30.01 23.20
GROUP 1-c.....\$ 30.01 23.20
GROUP 1-e.....\$ 30.34 23.20
GROUP 1-f.....\$ 30.37 23.20

GROUP 2.....	\$ 29.64	23.20
GROUP 3.....	\$ 29.54	23.20
GROUP 4.....	\$ 23.23	23.20

See groups 1-b and 1-d under laborer classifications.

LABORER (GARDENERS,  
HORTICULTURAL & LANDSCAPE  
LABORERS - AREA B:)

(1) New Construction.....	\$ 29.54	23.20
(2) Establishment Warranty Period.....	\$ 23.23	23.20

LABORER (GUNITE - AREA B:)

GROUP 1.....	\$ 29.75	22.31
GROUP 2.....	\$ 29.25	22.31
GROUP 3.....	\$ 28.66	22.31
GROUP 4.....	\$ 28.54	22.31

LABORER (WRECKING - AREA B:)

GROUP 1.....	\$ 29.79	23.20
GROUP 2.....	\$ 29.64	23.20

FOOTNOTES:

Laborers working off or with or from bos'n chairs, swinging scaffolds, belts shall receive \$0.25 per hour above the applicable wage rate. This shall not apply to workers entitled to receive the wage rate set forth in Group 1-a below.

-----

LABORER CLASSIFICATIONS

CONSTRUCTION SPECIALIST GROUP: Asphalt ironer and raker; Chainsaw; Laser beam in connection with laborers' work; Cast-in- place manhole form setter; Pressure pipelayer; Davis trencher - 300 or similar type (and all small trenchers); Blaster; Diamond driller; Multiple unit drill; Hydraulic drill

GROUP 1: Asphalt spreader boxes (all types); Barko, Wacker and similar type tampers; Buggymobile; Caulker, bander, pipewrapper, conduit layer, plastic pipelayer; Certified hazardous waste worker including Leade Abatement; Compactors of all types; Concrete and magnesite mixer, 1/2 yd. and under; Concrete pan work; Concrete sander; Concrete saw; Cribber and/or shoring; Cut granite curb setter; Dri-pak-it machine; Faller, logloader and bucket; Form raiser, slip forms; Green cutter; Headerboard, Hubsetter, aligner, by any method; High pressure blow pipe (1-1/2" or over, 100 lbs. pressure/over); Hydro seeder and similar type; Jackhammer operator; Jacking of pipe over 12 inches; Jackson and similar type compactor; Kettle tender, pot and worker applying asphalt, lay-kold, creosote, lime, caustic and similar type materials (applying means applying, dipping or handling of such materials); Lagging, sheeting, whaling, bracing, trenchjacking, lagging hammer; Magnesite, epoxyresin, fiberglass, mastic worker (wet or dry); No joint pipe and stripping of same, including repair of voids; Pavement breaker and spader, including tool grinder; Perma curb; Pipelayer (including grade checking in connection with pipelaying); Precast-manhole setter; Pressure pipe tester; Post hole digger, air, gas and electric; Power broom sweeper; Power tampers of all types (except as shown in Group 2); Ram set gun and stud gun; Riprap stonepaver and rock-slinger, including placing of sacked concrete and/or sand (wet or dry) and gabions and

similar type; Rotary scarifier or multiple head concrete chipping scarifier; Roto and Ditch Witch; Rototiller; Sandblaster, pot, gun, nozzle operators; Signalling and rigging; Tank cleaner; Tree climber; Turbo blaster; Vibrascreed, bull float in connection with laborers' work; Vibrator; Hazardous waste worker (lead removal); Asbestos and mold removal worker

GROUP 1-a: Joy drill model TWM-2A; Gardner-Denver model DH143 and similar type drills; Track driller; Jack leg driller; Wagon driller; Mechanical drillers, all types regardless of type or method of power; Mechanical pipe layers, all types regardless of type or method of power; Blaster and powder; All work of loading, placing and blasting of all powder and explosives of whatever type regardless of method used for such loading and placing; High scalers (including drilling of same); Tree topper; Bit grinder

GROUP 1-b: Sewer cleaners shall receive \$4.00 per day above Group 1 wage rates. "Sewer cleaner" means any worker who handles or comes in contact with raw sewage in small diameter sewers. Those who work inside recently active, large diameter sewers, and all recently active sewer manholes shall receive \$5.00 per day above Group 1 wage rates.

GROUP 1-c: Burning and welding in connection with laborers' work; Synthetic thermoplastics and similar type welding

GROUP 1-d: Maintenance and repair track and road beds. All employees performing work covered herein shall receive \$ .25 per hour above their regular rate for all work performed on underground structures not specifically covered herein. This paragraph shall not be construed to apply to work below ground level in open cut. It shall apply to cut and cover work of subway construction after the temporary cover has been placed.

GROUP 1-e: Work on and/or in bell hole footings and shafts thereof, and work on and in deep footings. (A deep footing is a hole 15 feet or more in depth.) In the event the depth of the footing is unknown at the commencement of excavation, and the final depth exceeds 15 feet, the deep footing wage rate would apply to all employees for each and every day worked on or in the excavation of the footing from the date of inception.

GROUP 1-f: Wire winding machine in connection with guniting or shot crete

GROUP 2: Asphalt shoveler; Cement dumper and handling dry cement or gypsum; Choke-setter and rigger (clearing work); Concrete bucket dumper and chute; Concrete chipping and grinding; Concrete laborer (wet or dry); Driller tender, chuck tender, nipper; Guinea chaser (stake), grout crew; High pressure nozzle, adductor; Hydraulic monitor (over 100 lbs. pressure); Loading and unloading, carrying and hauling of all rods and materials for use in reinforcing concrete construction; Pittsburgh chipper and similar type brush shredders; Sloper; Single foot, hand-held, pneumatic tamper; All pneumatic, air, gas and electric tools not listed in Groups 1 through 1-f; Jacking of pipe - under 12 inches

GROUP 3: Construction laborers, including bridge and general

laborer; Dump, load spotter; Flag person; Fire watcher; Fence erector; Guardrail erector; Gardener, horticultural and landscape laborer; Jetting; Limber, brush loader and piler; Pavement marker (button setter); Maintenance, repair track and road beds; Streetcar and railroad construction track laborer; Temporary air and water lines, Victaulic or similar; Tool room attendant (jobsite only)

GROUP 4: Final clean-up work of debris, grounds and building including but not limited to: street cleaner; cleaning and washing windows; brick cleaner (jobsite only); material cleaner (jobsite only). The classification "material cleaner" is to be utilized under the following conditions:

- A: at demolition site for the salvage of the material.
- B: at the conclusion of a job where the material is to be salvaged and stocked to be reused on another job.
- C: for the cleaning of salvage material at the jobsite or temporary jobsite yard.

The material cleaner classification should not be used in the performance of "form stripping, cleaning and oiling and moving to the next point of erection".

-----  
GUNITE LABORER CLASSIFICATIONS

- GROUP 1: Structural Nozzleman
- GROUP 2: Nozzleman, Gunman, Potman, Groundman
- GROUP 3: Reboundman
- GROUP 4: Guniting laborer

-----  
WRECKING WORK LABORER CLASSIFICATIONS

- GROUP 1: Skilled wrecker (removing and salvaging of sash, windows and materials)
- GROUP 2: Semi-skilled wrecker (salvaging of other building materials)

-----  
LAB00185-008 07/01/2018

	Rates	Fringes
Plasterer tender.....	\$ 32.02	23.00
Work on a swing stage scaffold: \$1.00 per hour additional.		

-----  
LAB00261-002 06/25/2018

MARIN COUNTY

	Rates	Fringes
LABORER (TRAFFIC CONTROL/LANE CLOSURE)		
Escort Driver, Flag Person..	\$ 30.54	23.65
Traffic Control Person I....	\$ 30.84	23.65
Traffic Control Person II...	\$ 28.34	23.65

TRAFFIC CONTROL PERSON I: Layout of traffic control, crash cushions, construction area and roadside signage.

TRAFFIC CONTROL PERSON II: Installation and removal of temporary/permanent signs, markers, delineators and crash cushions.

LAB00261-004 06/25/2018

MARIN COUNTY

	Rates	Fringes
Tunnel and Shaft Laborers:		
GROUP 1.....	\$ 37.82	24.11
GROUP 2.....	\$ 37.59	24.11
GROUP 3.....	\$ 37.34	24.11
GROUP 4.....	\$ 36.89	24.11
GROUP 5.....	\$ 36.35	24.11
Shotcrete Specialist.....	\$ 38.34	24.11

TUNNEL AND SHAFT CLASSIFICATIONS

GROUP 1: Diamond driller; Groundmen; Gunite and shotcrete nozzlelemen

GROUP 2: Rodmen; Shaft work & raise (below actual or excavated ground level)

GROUP 3: Bit grinder; Blaster, driller, powdermen, heading; Cherry pickermen - where car is lifted; Concrete finisher in tunnel; Concrete screedman; Grout pumpman and potman; Gunite & shotcrete gunman & potman; Headermen; High pressure nozzleman; Miner - tunnel, including top and bottom man on shaft and raise work; Nipper; Nozzleman on slick line; Sandblaster - potman, Robotic Shotcrete Placer, Segment Erector, Tunnel Muck Hauler, Steel Form raiser and setter; Timberman, retimberman (wood or steel or substitute materials therefore); Tugger (for tunnel laborer work); Cable tender; Chuck tender; Powderman - primer house

GROUP 4: Vibrator operator, pavement breaker; Bull gang - muckers, trackmen; Concrete crew - includes rodding and spreading, Dumpmen (any method)

GROUP 5: Grout crew; Reboundman; Swamper/ Brakeman

LAB00261-007 07/01/2018

MARIN AND NAPA COUNTIES

	Rates	Fringes
LABORER		
Mason Tender-Brick.....	\$ 32.45	22.20

LAB00261-010 06/25/2018

MARIN COUNTY

	Rates	Fringes
--	-------	---------

LABORER (CONSTRUCTION CRAFT

LABORERS - AREA A:)

Construction Specialist

Group.....	\$ 31.49	23.20
GROUP 1.....	\$ 30.79	23.20
GROUP 1-a.....	\$ 31.01	23.20
GROUP 1-c.....	\$ 30.84	23.20
GROUP 1-e.....	\$ 31.34	23.20
GROUP 1-f.....	\$ 31.37	23.20
GROUP 2.....	\$ 30.64	23.20
GROUP 3.....	\$ 30.54	23.20
GROUP 4.....	\$ 24.23	23.20

See groups 1-b and 1-d under laborer classifications.

LABORER (GARDENERS,

HORTICULTURAL & LANDSCAPE

LABORERS - AREA A:)

(1) New Construction.....	\$ 30.54	23.20
(2) Establishment Warranty		
Period.....	\$ 24.23	23.20

LABORER (GUNITITE - AREA A:)

GROUP 1.....	\$ 30.75	22.31
GROUP 2.....	\$ 30.25	22.31
GROUP 3.....	\$ 29.66	22.31
GROUP 4.....	\$ 29.54	22.31

LABORER (WRECKING - AREA A:)

GROUP 1.....	\$ 30.79	23.20
GROUP 2.....	\$ 30.64	23.20

FOOTNOTES:

Laborers working off or with or from bos'n chairs, swinging scaffolds, belts shall receive \$0.25 per hour above the applicable wage rate. This shall not apply to workers entitled to receive the wage rate set forth in Group 1-a below.

LABORER CLASSIFICATIONS

CONSTRUCTION SPECIALIST GROUP: Asphalt ironer and raker; Chainsaw; Laser beam in connection with laborers' work; Cast-in- place manhole form setter; Pressure pipelayer; Davis trencher - 300 or similar type (and all small trenchers); Blaster; Diamond driller; Multiple unit drill; Hydraulic drill

GROUP 1: Asphalt spreader boxes (all types); Barko, Wacker and similar type tampers; Buggymobile; Caulker, bander, pipewrapper, conduit layer, plastic pipelayer; Certified hazardous waste worker including Leade Abatement; Compactors of all types; Concrete and magnesite mixer, 1/2 yd. and under; Concrete pan work; Concrete sander; Concrete saw; Cribber and/or shoring; Cut granite curb setter; Dri-pak-it machine; Faller, logloader and bucket; Form raiser, slip forms; Green cutter; Headerboard, Hubsetter, aligner, by any method; High pressure blow pipe (1-1/2" or over, 100 lbs. pressure/over); Hydro seeder and similar type; Jackhammer operator; Jacking of pipe over 12 inches; Jackson and similar type compactor; Kettle tender, pot and worker applying asphalt, lay-kold, creosote, lime, caustic and similar type materials (applying means applying, dipping or handling of such materials); Lagging, sheeting, whaling, bracing, trenchjacking, lagging hammer; Magnesite, epoxyresin, fiberglass, mastic worker (wet or dry); No

joint pipe and stripping of same, including repair of voids; Pavement breaker and spader, including tool grinder; Perma curb; Pipelayer (including grade checking in connection with pipelaying); Precast-manhole setter; Pressure pipe tester; Post hole digger, air, gas and electric; Power broom sweeper; Power tampers of all types (except as shown in Group 2); Ram set gun and stud gun; Riprap stonepaver and rock-slinger, including placing of sacked concrete and/or sand (wet or dry) and gabions and similar type; Rotary scarifier or multiple head concrete chipping scarifier; Roto and Ditch Witch; Rototiller; Sandblaster, pot, gun, nozzle operators; Signalling and rigging; Tank cleaner; Tree climber; Turbo blaster; Vibrascreed, bull float in connection with laborers' work; Vibrator; Hazardous waste worker (lead removal); Asbestos and mold removal worker

GROUP 1-a: Joy drill model TWM-2A; Gardner-Denver model DH143 and similar type drills; Track driller; Jack leg driller; Wagon driller; Mechanical drillers, all types regardless of type or method of power; Mechanical pipe layers, all types regardless of type or method of power; Blaster and powder; All work of loading, placing and blasting of all powder and explosives of whatever type regardless of method used for such loading and placing; High scalers (including drilling of same); Tree topper; Bit grinder

GROUP 1-b: Sewer cleaners shall receive \$4.00 per day above Group 1 wage rates. "Sewer cleaner" means any worker who handles or comes in contact with raw sewage in small diameter sewers. Those who work inside recently active, large diameter sewers, and all recently active sewer manholes shall receive \$5.00 per day above Group 1 wage rates.

GROUP 1-c: Burning and welding in connection with laborers' work; Synthetic thermoplastics and similar type welding

GROUP 1-d: Maintenance and repair track and road beds. All employees performing work covered herein shall receive \$ .25 per hour above their regular rate for all work performed on underground structures not specifically covered herein. This paragraph shall not be construed to apply to work below ground level in open cut. It shall apply to cut and cover work of subway construction after the temporary cover has been placed.

GROUP 1-e: Work on and/or in bell hole footings and shafts thereof, and work on and in deep footings. (A deep footing is a hole 15 feet or more in depth.) In the event the depth of the footing is unknown at the commencement of excavation, and the final depth exceeds 15 feet, the deep footing wage rate would apply to all employees for each and every day worked on or in the excavation of the footing from the date of inception.

GROUP 1-f: Wire winding machine in connection with guniting or shot crete

GROUP 2: Asphalt shoveler; Cement dumper and handling dry cement or gypsum; Choke-setter and rigger (clearing work); Concrete bucket dumper and chute; Concrete chipping and grinding; Concrete laborer (wet or dry); Driller tender, chuck tender, nipper; Guinea chaser (stake), grout crew; High pressure nozzle, adductor; Hydraulic monitor (over 100



lbs. pressure); Loading and unloading, carrying and hauling of all rods and materials for use in reinforcing concrete construction; Pittsburgh chipper and similar type brush shredders; Sloper; Single foot, hand-held, pneumatic tamper; All pneumatic, air, gas and electric tools not listed in Groups 1 through 1-f; Jacking of pipe - under 12 inches

GROUP 3: Construction laborers, including bridge and general laborer; Dump, load spotter; Flag person; Fire watcher; Fence erector; Guardrail erector; Gardener, horticultural and landscape laborer; Jetting; Limber, brush loader and piler; Pavement marker (button setter); Maintenance, repair track and road beds; Streetcar and railroad construction track laborer; Temporary air and water lines, Victaulic or similar; Tool room attendant (jobsite only)

GROUP 4: Final clean-up work of debris, grounds and building including but not limited to: street cleaner; cleaning and washing windows; brick cleaner (jobsite only); material cleaner (jobsite only). The classification "material cleaner" is to be utilized under the following conditions:

- A: at demolition site for the salvage of the material.
- B: at the conclusion of a job where the material is to be salvaged and stocked to be reused on another job.
- C: for the cleaning of salvage material at the jobsite or temporary jobsite yard.

The material cleaner classification should not be used in the performance of "form stripping, cleaning and oiling and moving to the next point of erection".

-----  
GUNITE LABORER CLASSIFICATIONS

- GROUP 1: Structural Nozzleman
- GROUP 2: Nozzleman, Gunman, Potman, Groundman
- GROUP 3: Reboundman
- GROUP 4: Gunite laborer

-----  
WRECKING WORK LABORER CLASSIFICATIONS

- GROUP 1: Skilled wrecker (removing and salvaging of sash, windows and materials)
- GROUP 2: Semi-skilled wrecker (salvaging of other building materials)

-----  
LAB00261-015 07/01/2018

	Rates	Fringes
Plasterer tender.....	\$ 32.02	23.00
Work on a swing stage scaffold: \$1.00 per hour additional.		

-----  
LAB00324-004 06/25/2018

NAPA, SOLANO, AND SONOMA, COUNTIES

Rates Fringes

LABORER (TRAFFIC CONTROL/LANE CLOSURE)

Escort Driver, Flag Person..\$	29.54	23.65
Traffic Control Person I....\$	29.84	23.65
Traffic Control Person II...\$	27.34	23.65

TRAFFIC CONTROL PERSON I: Layout of traffic control, crash cushions, construction area and roadside signage.

TRAFFIC CONTROL PERSON II: Installation and removal of temporary/permanent signs, markers, delineators and crash cushions.

-----  
LABO0324-008 06/25/2018

NAPA, SOLANO, AND SONOMA COUNTIES

Rates Fringes

Tunnel and Shaft Laborers:

GROUP 1.....\$	37.82	24.11
GROUP 2.....\$	37.59	24.11
GROUP 3.....\$	37.34	24.11
GROUP 4.....\$	36.89	24.11
GROUP 5.....\$	36.35	24.11
Shotcrete Specialist.....\$	38.34	24.11

TUNNEL AND SHAFT CLASSIFICATIONS

GROUP 1: Diamond driller; Groundmen; Gunite and shotcrete nozzlelemen

GROUP 2: Rodmen; Shaft work & raise (below actual or excavated ground level)

GROUP 3: Bit grinder; Blaster, driller, powdermen, heading; Cherry pickermen - where car is lifted; Concrete finisher in tunnel; Concrete screedman; Grout pumpman and potman; Gunite & shotcrete gunman & potman; Headermen; High pressure nozzleleman; Miner - tunnel, including top and bottom man on shaft and raise work; Nipper; Nozzleman on slick line; Sandblaster - potman, Robotic Shotcrete Placer, Segment Erector, Tunnel Muck Hauler, Steel Form raiser and setter; Timberman, retimberman (wood or steel or substitute materials therefore); Tugger (for tunnel laborer work); Cable tender; Chuck tender; Powderman - primer house

GROUP 4: Vibrator operator, pavement breaker; Bull gang - muckers, trackmen; Concrete crew - includes rodding and spreading, Dumpmen (any method)

GROUP 5: Grout crew; Reboundman; Swamper/ Brakeman

-----  
LABO0324-010 07/01/2018

SOLANO AND SONOMA COUNTIES

Rates Fringes

LABORER

Mason Tender-Brick.....\$ 31.45 22.20

LABO0324-013 06/25/2018

NAPA, SOLANO, AND SONOMA COUNTIES

Rates Fringes

LABORER (CONSTRUCTION CRAFT

LABORERS - AREA B:)

Construction Specialist

Table with 2 columns: Rate and Fringes. Rows include Group 1 through Group 4 with various sub-classifications and their respective rates and fringe benefits.

See groups 1-b and 1-d under laborer classifications.

LABORER (GARDENERS, HORTICULTURAL & LANDSCAPE

LABORERS - AREA B:)

Table with 2 columns: Rate and Fringes. Rows include (1) New Construction and (2) Establishment Warranty with their respective rates and fringe benefits.

LABORER (GUNITE - AREA B:)

Table with 2 columns: Rate and Fringes. Rows include Group 1 through Group 4 with their respective rates and fringe benefits.

LABORER (WRECKING - AREA B:)

Table with 2 columns: Rate and Fringes. Rows include Group 1 and Group 2 with their respective rates and fringe benefits.

FOOTNOTES:

Laborers working off or with or from bos'n chairs, swinging scaffolds, belts shall receive \$0.25 per hour above the applicable wage rate. This shall not apply to workers entitled to receive the wage rate set forth in Group 1-a below.

LABORER CLASSIFICATIONS

CONSTRUCTION SPECIALIST GROUP: Asphalt ironer and raker; Chainsaw; Laser beam in connection with laborers' work; Cast-in-place manhole form setter; Pressure pipelayer; Davis trencher - 300 or similar type (and all small trenchers); Blaster; Diamond driller; Multiple unit drill; Hydraulic drill

GROUP 1: Asphalt spreader boxes (all types); Barko, Wacker and similar type tampers; Buggymobile; Caulker, bander, pipewrapper, conduit layer, plastic pipelayer; Certified hazardous waste worker including Leade Abatement; Compactors of all types; Concrete and magnesite mixer, 1/2 yd. and under; Concrete pan work; Concrete sander; Concrete saw; Cribber and/or shoring; Cut granite curb setter; Dri-pak-it machine; Faller, logloader and buckler; Form raiser, slip forms; Green cutter; Headerboard, Hubsetter,

aligner, by any method; High pressure blow pipe (1-1/2" or over, 100 lbs. pressure/over); Hydro seeder and similar type; Jackhammer operator; Jacking of pipe over 12 inches; Jackson and similar type compactor; Kettle tender, pot and worker applying asphalt, lay-kold, creosote, lime, caustic and similar type materials (applying means applying, dipping or handling of such materials); Lagging, sheeting, whaling, bracing, trenchjacking, lagging hammer; Magnesite, epoxyresin, fiberglass, mastic worker (wet or dry); No joint pipe and stripping of same, including repair of voids; Pavement breaker and spader, including tool grinder; Perma curb; Pipelayer (including grade checking in connection with pipelaying); Precast-manhole setter; Pressure pipe tester; Post hole digger, air, gas and electric; Power broom sweeper; Power tampers of all types (except as shown in Group 2); Ram set gun and stud gun; Riprap stonepaver and rock-slinger, including placing of sacked concrete and/or sand (wet or dry) and gabions and similar type; Rotary scarifier or multiple head concrete chipping scarifier; Roto and Ditch Witch; Rototiller; Sandblaster, pot, gun, nozzle operators; Signalling and rigging; Tank cleaner; Tree climber; Turbo blaster; Vibrascreed, bull float in connection with laborers' work; Vibrator; Hazardous waste worker (lead removal); Asbestos and mold removal worker

GROUP 1-a: Joy drill model TWM-2A; Gardner-Denver model DH143 and similar type drills; Track driller; Jack leg driller; Wagon driller; Mechanical drillers, all types regardless of type or method of power; Mechanical pipe layers, all types regardless of type or method of power; Blaster and powder; All work of loading, placing and blasting of all powder and explosives of whatever type regardless of method used for such loading and placing; High scalers (including drilling of same); Tree topper; Bit grinder

GROUP 1-b: Sewer cleaners shall receive \$4.00 per day above Group 1 wage rates. "Sewer cleaner" means any worker who handles or comes in contact with raw sewage in small diameter sewers. Those who work inside recently active, large diameter sewers, and all recently active sewer manholes shall receive \$5.00 per day above Group 1 wage rates.

GROUP 1-c: Burning and welding in connection with laborers' work; Synthetic thermoplastics and similar type welding

GROUP 1-d: Maintenance and repair track and road beds. All employees performing work covered herein shall receive \$ .25 per hour above their regular rate for all work performed on underground structures not specifically covered herein. This paragraph shall not be construed to apply to work below ground level in open cut. It shall apply to cut and cover work of subway construction after the temporary cover has been placed.

GROUP 1-e: Work on and/or in bell hole footings and shafts thereof, and work on and in deep footings. (A deep footing is a hole 15 feet or more in depth.) In the event the depth of the footing is unknown at the commencement of excavation, and the final depth exceeds 15 feet, the deep footing wage rate would apply to all employees for each and every day worked on or in the excavation of the footing from the date of inception.

GROUP 1-f: Wire winding machine in connection with guniting or shot crete

GROUP 2: Asphalt shoveler; Cement dumper and handling dry cement or gypsum; Choke-setter and rigger (clearing work); Concrete bucket dumper and chute; Concrete chipping and grinding; Concrete laborer (wet or dry); Driller tender, chuck tender, nipper; Guinea chaser (stake), grout crew; High pressure nozzle, adductor; Hydraulic monitor (over 100 lbs. pressure); Loading and unloading, carrying and hauling of all rods and materials for use in reinforcing concrete construction; Pittsburgh chipper and similar type brush shredders; Sloper; Single foot, hand-held, pneumatic tamper; All pneumatic, air, gas and electric tools not listed in Groups 1 through 1-f; Jacking of pipe - under 12 inches

GROUP 3: Construction laborers, including bridge and general laborer; Dump, load spotter; Flag person; Fire watcher; Fence erector; Guardrail erector; Gardener, horticultural and landscape laborer; Jetting; Limber, brush loader and piler; Pavement marker (button setter); Maintenance, repair track and road beds; Streetcar and railroad construction track laborer; Temporary air and water lines, Victaulic or similar; Tool room attendant (jobsite only)

GROUP 4: Final clean-up work of debris, grounds and building including but not limited to: street cleaner; cleaning and washing windows; brick cleaner (jobsite only); material cleaner (jobsite only). The classification "material cleaner" is to be utilized under the following conditions:

- A: at demolition site for the salvage of the material.
- B: at the conclusion of a job where the material is to be salvaged and stocked to be reused on another job.
- C: for the cleaning of salvage material at the jobsite or temporary jobsite yard.

The material cleaner classification should not be used in the performance of "form stripping, cleaning and oiling and moving to the next point of erection".

-----  
GUNITE LABORER CLASSIFICATIONS

- GROUP 1: Structural Nozzleman
- GROUP 2: Nozzleman, Gunman, Potman, Groundman
- GROUP 3: Reboundman
- GROUP 4: Gunite laborer

-----  
WRECKING WORK LABORER CLASSIFICATIONS

- GROUP 1: Skilled wrecker (removing and salvaging of sash, windows and materials)
- GROUP 2: Semi-skilled wrecker (salvaging of other building materials)

-----  
LAB00324-019 07/01/2018

	Rates	Fringes
Plasterer tender.....	\$ 32.02	23.00

Work on a swing stage scaffold: \$1.00 per hour additional.

-----  
\* PAIN0016-004 01/01/2019

MARIN, NAPA, SOLANO & SONOMA COUNTIES

	Rates	Fringes
Painters:.....	\$ 42.67	24.03

PREMIUMS:

EXOTIC MATERIALS - \$0.75 additional per hour.

SPRAY WORK: - \$0.50 additional per hour.

INDUSTRIAL PAINTING - \$0.25 additional per hour

[Work on industrial buildings used for the manufacture and processing of goods for sale or service; steel construction (bridges), stacks, towers, tanks, and similar structures]

HIGH WORK:

over 50 feet - \$2.00 per hour additional

100 to 180 feet - \$4.00 per hour additional

Over 180 feet - \$6.00 per hour additional

-----  
PAIN0016-005 01/01/2018

ALPINE, BUTTE, COLUSA, EL DORADO (west of the Sierra Nevada Mountains), GLENN, LASSEN (west of Hwy. 395, excluding Honey Lake); MARIN, MODOC, NAPA, NEVADA (west of the Sierra Nevada Mountains), PLACER (west of the Sierra Nevada Mountains), PLUMAS, SACRAMENTO, SHASTA, SIERRA (west of the Sierra Nevada Mountains), SISKIYOU, SOLANO, SONOMA, SUTTER, TEHAMA, TRINITY, YOLO AND YUBA COUNTIES

	Rates	Fringes
DRYWALL FINISHER/TAPER.....	\$ 41.03	25.34

-----  
\* PAIN0016-007 01/01/2019

ALPINE, AMADOR, BUTTE, COLUSA. EL DORADO (west of the Sierra Nevada Mountains), GLENN, LASSEN (west of Highway 395, excluding Honey Lake), MODOC, NEVADA (west of the Sierra Nevada Mountains), PLACER (west of the Sierra Nevada Mountains), PLUMAS, SACRAMENTO, SHASTA, SIERRA (west of the Sierra Nevada Mountains), SISKIYOU, SUTTER, TEHAMA, TRINITY, YOLO & YUBA COUNTIES

	Rates	Fringes
Painters:.....	\$ 33.68	20.24

SPRAY/SANDBLAST: \$0.50 additional per hour.

EXOTIC MATERIALS: \$1.00 additional per hour.

HIGH TIME: Over 50 ft above ground or water level \$2.00 additional per hour. 100 to 180 ft above ground or water level \$4.00 additional per hour. Over 180 ft above ground or water level \$6.00 additional per hour.

-----  
PAIN0016-008 01/01/2019

MARIN, NAPA, SOLANO AND SONOMA COUNTIES

	Rates	Fringes
SOFT FLOOR LAYER.....	\$ 48.60	27.43

-----  
\* PAIN0169-004 01/01/2019

MARIN , NAPA & SONOMA COUNTIES; SOLANO COUNTY (west of a line defined as follows: Hwy. 80 corridor beginning at the City of Fairfield, including Travis Air Force Base and Suisun City; going north of Manakas Corner Rd., continue north on Suisun Valley Rd. to the Napa County line; Hwy. 80 corridor south on Grizzly Island Rd. to the Grizzly Island Management area)

	Rates	Fringes
GLAZIER.....	\$ 50.03	28.19

-----  
\* PAIN0567-001 07/01/2018

EL DORADO COUNTY (east of the Sierra Nevada Mountains); LASSEN COUNTY (east of Highway 395, beginning at Stacey and including Honey Lake); NEVADA COUNTY (east of the Sierra Nevada Mountains); PLACER COUNTY (east of the Sierra Nevada Mountains); AND SIERRA COUNTY (east of the Sierra Nevada Mountains)

	Rates	Fringes
Painters:		
Brush and Roller.....	\$ 26.70	13.04
Spray Painter & Paperhanger.	\$ 28.04	13.04

PREMIUMS:  
Special Coatings (Brush), and Sandblasting = \$0.50/hr  
Special Coatings (Spray), and Steeplejack = \$1.00/hr  
Special Coating Spray Steel = \$1.25/hr  
Swing Stage = \$2.00/hr

\*A special coating is a coating that requires the mixing of 2 or more products.

-----  
PAIN0567-007 07/01/2018

EL DORADO COUNTY (east of the Sierra Nevada Mountains); LASSEN COUNTY (east of Highway 395, beginning at Stacey and including Honey Lake); NEVADA COUNTY (east of the Sierra Nevada Mountains); PLACER COUNTY (east of the Sierra Nevada Mountains) AND SIERRA COUNTY (east of the Sierra Nevada Mountains)

	Rates	Fringes
SOFT FLOOR LAYER.....	\$ 29.10	13.14

-----  
PAIN0567-010 07/01/2018

EL DORADO COUNTY (east of the Sierra Nevada Mountains); LASSEN COUNTY (east of Highway 395, beginning at Stacey and including Honey Lake); NEVADA COUNTY (east of the Sierra Nevada Mountains); PLACER COUNTY (east of the Sierra Nevada Mountains); AND SIERRA COUNTY (east of the Sierra Nevada Mountains)

	Rates	Fringes
Drywall		
(1) Taper.....	\$ 31.82	13.04
(2) Steeplejack - Taper, over 40 ft with open space below.....	\$ 33.32	13.04

-----  
\* PAIN0767-004 01/01/2019

ALPINE, AMADOR, BUTTE, COLUSA, EL DORADO, GLENN, LASSEN, MODOC, NEVADA, PLACER, PLUMAS, SACRAMENTO, SHASTA, SIERRA, SISKIYOU, SOLANO (Remainder), SUTTER, TEHAMA, TRINITY, YOLO, YUBA

	Rates	Fringes
GLAZIER.....	\$ 38.47	28.40

PAID HOLIDAYS: New Year's Day, Martin Luther King, Jr. Day, President's Day, Memorial Day, Independence Day, Labor Day, Veteran's Day, Thanksgiving Day, and Christmas Day.

Employee required to wear a body harness shall receive \$1.50 per hour above the basic hourly rate at any elevation.

-----  
PAIN1176-001 01/01/2017

HIGHWAY IMPROVEMENT

	Rates	Fringes
Parking Lot Striping/Highway Marking:		
GROUP 1.....	\$ 34.41	16.31
GROUP 2.....	\$ 29.25	16.31
GROUP 3.....	\$ 29.59	16.31

CLASSIFICATIONS

GROUP 1: Striper: Layout and application of painted traffic stripes and marking; hot thermo plastic; tape, traffic stripes and markings

GROUP 2: Gamecourt & Playground Installer

GROUP 3: Protective Coating, Pavement Sealing

-----  
PAIN1237-001 10/01/2018

ALPINE; COLUSA; EL DORADO (west of the Sierra Nevada Mountains); GLENN; LASSEN (west of Highway 395, beginning at Stacey and including Honey Lake); MODOC; NEVADA (west of the Sierra Nevada Mountains); PLACER (west of the Sierra Nevada Mountains); PLUMAS; SACRAMENTO; SHASTA; SIERRA (west of the



Sierra Nevada Mountains); SISKIYOU; SUTTER; TEHAMA; TRINITY;  
YOLO AND YUBA COUNTIES

	Rates	Fringes
SOFT FLOOR LAYER.....	\$ 36.81	21.51
-----		
PLAS0300-003 07/01/2018		

	Rates	Fringes
PLASTERER		
AREA 295: Alpine, Amador, Butte, Colusa, El Dorado, Glenn, Lassen, Modoc, Nevada, Placer, Plumas, Sacramento, Shasta, Sierra, Siskiyou, Solano, Sutter, Tehema, Trinity, Yolo & Yuba Counties.....	\$ 32.70	31.68
AREA 355: Marin.....	\$ 36.73	31.68
AREA 355: Napa & Sonoma Counties.....	\$ 32.70	31.68
-----		
PLAS0300-005 07/01/2017		

	Rates	Fringes
CEMENT MASON/CONCRETE FINISHER...	\$ 33.49	23.67
-----		
PLUM0038-002 07/01/2018		

MARIN AND SONOMA COUNTIES

	Rates	Fringes
PLUMBER (Plumber, Steamfitter, Refrigeration Fitter)		
(1) Work on wooden frame structures 5 stories or less excluding hgh-rise buildings and commercial work such as hospitals, prisons, hotels, schools, casinos, wastewater treatment plants, and resarch facilities as well as refrigeration pipefitting, service and repair work - MARKET RECOVERY RATE.....	\$ 72.00	41.94
(2) All other work - NEW CONSTRUCTION RATE.....	\$ 72.00	41.94
-----		
PLUM0038-006 07/01/2018		

MARIN & SONOMA COUNTIES

	Rates	Fringes
Landscape/Irrigation Fitter (Underground/Utility Fitter).....	\$ 61.20	30.17
-----		

PLUM0228-001 01/01/2019

BUTTE, COLUSA, GLENN, LASSEN, MODOC, PLUMAS, SHASTA, SIERRA, SISKIYOU, SUTTER, TEHAMA, TRINITY & YUBA COUNTIES

	Rates	Fringes
PLUMBER.....	\$ 40.00	31.89

-----  
PLUM0343-001 01/01/2019

NAPA AND SOLANO COUNTIES

	Rates	Fringes
PLUMBER/PIPEFITTER		
Light Commercial.....	\$ 30.85	20.40
All Other Work.....	\$ 51.00	38.50

DEFINITION OF LIGHT COMMERCIAL:

Work shall include strip shopping centers, office buildings, schools and other commercial structures which the total plumbing bid does not exceed Two Hundred and Fifty Thousand (\$250,000) and the total heating and cooling does not exceed Two Hundred Fifty Thousand (\$250,000); or Any projects bid in phases shall not qualify unless the total project is less than Two Hundred Fifty Thousand (\$250,000) for the plumbing bid; and Two Hundred Fifty Thousand (\$250,000) for the heating and cooling bid. Excluded are hospitals, jails, institutions and industrial projects, regardless size of the project

FOOTNOTES: While fitting galvanized material: \$.75 per hour additional. Work from trusses, temporary staging, unguarded structures 35' from the ground or water: \$.75 per hour additional. Work from swinging scaffolds, boatswains chairs or similar devices: \$.75 per hour additional.

-----  
PLUM0350-001 08/01/2018

EL DORADO COUNTY (Lake Tahoe area only); NEVADA COUNTY (Lake Tahoe area only); AND PLACER COUNTY (Lake Tahoe area only)

	Rates	Fringes
PLUMBER/PIPEFITTER.....	\$ 42.84	13.81

-----  
PLUM0355-001 07/01/2018

ALPINE, AMADOR, BUTTE, COLUSA, EL DORADO, GLENN, LASSEN, MODOC, NAPA, NEVADA, PLACER, PLUMAS, SACRAMENTO, SHASTA, SIERRA, SISKIYOU, SOLANO, SUTTER, TEHAMA, TRINITY, YOLO, AND YUBA COUNTIES

	Rates	Fringes
Underground Utility Worker		
/Landscape Fitter.....	\$ 27.10	16.30

-----  
PLUM0442-003 01/01/2019

AMADOR (South of San Joaquin River) and ALPINE COUNTIES

	Rates	Fringes
PLUMBER.....	\$ 42.25	30.64
-----		
* PLUM0447-001 07/01/2018		

AMADOR (north of San Joaquin River), EL DORADO (excluding Lake Tahoe area), NEVADA (excluding Lake Tahoe area); PLACER (excluding Lake Tahoe area), SACRAMENTO AND YOLO COUNTIES

	Rates	Fringes
PLUMBER/PIPEFITTER		
Journeyman.....	\$ 49.67	25.00
Light Commercial Work.....	\$ 36.23	17.72
-----		
ROOF0081-006 08/01/2018		

MARIN, NAPA, SOLANO AND SONOMA COUNTIES

	Rates	Fringes
Rofer.....	\$ 39.40	17.58
-----		
ROOF0081-007 08/01/2018		

ALPINE, BUTTE, COLUSA, EL DORADO, GLENN, LASSEN, MODOC, NEVADA, PLACER, PLUMAS, SACRAMENTO, SHASTA, SIERRA, SISKIYOU, SUTTER, TEHAMA, TRINITY, YOLO, AND YUBA COUNTIES

	Rates	Fringes
Rofer.....	\$ 36.57	18.23
-----		
* SFCA0483-003 01/01/2019		

MARIN, NAPA, SOLANO AND SONOMA COUNTIES

	Rates	Fringes
SPRINKLER FITTER (Fire Sprinklers).....	\$ 63.52	31.17
-----		
SFCA0669-003 04/01/2017		

ALPINE, BUTTE, COLUSA, EL DORADO, GLENN, LASSEN, MODOC, NEVADA, PLACER, PLUMAS, SACRAMENTO, SHASTA, SIERRA, SISKIYOU, SUTTER, TEHAMA, TRINITY, YOLO AND YUBA COUNTIES

	Rates	Fringes
SPRINKLER FITTER.....	\$ 37.20	15.84
-----		
SHEE0104-006 07/02/2018		

MARIN, NAPA, SOLANO SONOMA & TRINITY COUNTIES

	Rates	Fringes
Sheet Metal Worker		

Mechanical Contracts		
\$200,000 or less.....	\$ 51.87	37.19
All other work.....	\$ 59.11	38.54

-----  
SHEE0104-009 07/01/2018

AMADOR, COLUSA, EL DORADO, NEVADA, PLACER, SACRAMENTO, SUTTER,  
YOLO AND YUBA COUNTIES

	Rates	Fringes
SHEET METAL WORKER.....	\$ 42.91	34.45

-----  
SHEE0104-010 07/01/2018

ALPINE COUNTY

	Rates	Fringes
SHEET METAL WORKER.....	\$ 40.34	32.80

-----  
SHEE0104-011 07/01/2018

BUTTE, COLUSA, EL DORADO, GLENN, LASSEN, MODOC, NEVADA, PLACER,  
PLUMAS, SACRAMENTO, SHASTA, SIERRA, SISKIYOU, SUTTER, TEHAMA,  
YOLO AND YUBA COUNTIES

	Rates	Fringes
Sheet Metal Worker (Metal decking and siding only).....	\$ 39.93	32.70

-----  
SHEE0104-014 07/01/2017

MARIN, NAPA, SOLANO, SONOMA AND TRINITY COUNTIES

	Rates	Fringes
SHEET METAL WORKER (Metal Decking and Siding only).....	\$ 37.53	32.10

-----  
SHEE0104-019 07/01/2018

BUTTE, GLENN, LASSEN, MODOC, PLUMAS, SHASTA, SIERRA, SISKIYOU  
AND TEHAMA COUNTIES

	Rates	Fringes
SHEET METAL WORKER		
Mechanical Jobs \$200,000 & under.....	\$ 32.21	32.29
Mechanical Jobs over \$200,000.....	\$ 42.91	34.43

-----  
TEAM0094-001 07/01/2018

	Rates	Fringes
Truck drivers:		
GROUP 1.....	\$ 31.68	27.86
GROUP 2.....	\$ 31.98	27.86
GROUP 3.....	\$ 32.28	27.86

GROUP 4.....	\$ 32.63	27.86
GROUP 5.....	\$ 32.98	27.86

FOOTNOTES:

Articulated dump truck; Bulk cement spreader (with or without auger); Dumpcrete truck; Skid truck (debris box); Dry pre-batch concrete mix trucks; Dumpster or similar type; Slurry truck: Use dump truck yardage rate.  
 Heater planer; Asphalt burner; Scarifier burner; Industrial lift truck (mechanical tailgate); Utility and clean-up truck: Use appropriate rate for the power unit or the equipment utilized.

TRUCK DRIVER CLASSIFICATIONS

GROUP 1: Dump trucks, under 6 yds.; Single unit flat rack (2-axle unit); Nipper truck (when flat rack truck is used appropriate flat rack shall apply); Concrete pump truck (when flat rack truck is used appropriate flat rack shall apply); Concrete pump machine; Fork lift and lift jitneys; Fuel and/or grease truck driver or fuel person; Snow buggy; Steam cleaning; Bus or personhaul driver; Escort or pilot car driver; Pickup truck; Teamster oiler/greaser and/or serviceperson; Hook tender (including loading and unloading); Team driver; Tool room attendant (refineries)

GROUP 2: Dump trucks, 6 yds. and under 8 yds.; Transit mixers, through 10 yds.; Water trucks, under 7,000 gals.; Jetting trucks, under 7,000 gals.; Single-unit flat rack (3-axle unit); Highbed heavy duty transport; Scissor truck; Rubber-tired muck car (not self-loaded); Rubber-tired truck jumbo; Winch truck and "A" frame drivers; Combination winch truck with hoist; Road oil truck or bootperson; Buggymobile; Ross, Hyster and similar straddle carriers; Small rubber-tired tractor

GROUP 3: Dump trucks, 8 yds. and including 24 yds.; Transit mixers, over 10 yds.; Water trucks, 7,000 gals. and over; Jetting trucks, 7,000 gals. and over; Vacuum trucks under 7500 gals. Trucks towing tilt bed or flat bed pull trailers; Lowbed heavy duty transport; Heavy duty transport tiller person; Self-propelled street sweeper with self-contained refuse bin; Boom truck - hydro-lift or Swedish type extension or retracting crane; P.B. or similar type self-loading truck; Tire repairperson; Combination bootperson and road oiler; Dry distribution truck (A bootperson when employed on such equipment, shall receive the rate specified for the classification of road oil trucks or bootperson); Ammonia nitrate distributor, driver and mixer; Snow Go and/or plow

GROUP 4: Dump trucks, over 25 yds. and under 65 yds.; Water pulls - DW 10's, 20's, 21's and other similar equipment when pulling Aqua/pak or water tank trailers; Helicopter pilots (when transporting men and materials); Lowbedk Heavy Duty Transport up to including 7 axles; DW10's, 20's, 21's and other similar Cat type, Terra Cobra, LeTourneau Pulls, Tournorocker, Euclid and similar type equipment when pulling fuel and/or grease tank trailers or other miscellaneous trailers; Vacuum Trucks 7500 gals and over and truck repairman

GROUP 5: Dump trucks, 65 yds. and over; Holland hauler; Low bed Heavy Duty Transport over 7 axles

-----  
WELDERS - Receive rate prescribed for craft performing operation to which welding is incidental.

=====  
Note: Executive Order (EO) 13706, Establishing Paid Sick Leave for Federal Contractors applies to all contracts subject to the Davis-Bacon Act for which the contract is awarded (and any solicitation was issued) on or after January 1, 2017. If this contract is covered by the EO, the contractor must provide employees with 1 hour of paid sick leave for every 30 hours they work, up to 56 hours of paid sick leave each year. Employees must be permitted to use paid sick leave for their own illness, injury or other health-related needs, including preventive care; to assist a family member (or person who is like family to the employee) who is ill, injured, or has other health-related needs, including preventive care; or for reasons resulting from, or to assist a family member (or person who is like family to the employee) who is a victim of, domestic violence, sexual assault, or stalking. Additional information on contractor requirements and worker protections under the EO is available at [www.dol.gov/whd/govcontracts](http://www.dol.gov/whd/govcontracts).

Unlisted classifications needed for work not included within the scope of the classifications listed may be added after award only as provided in the labor standards contract clauses (29CFR 5.5 (a) (1) (ii)).

-----  
The body of each wage determination lists the classification and wage rates that have been found to be prevailing for the cited type(s) of construction in the area covered by the wage determination. The classifications are listed in alphabetical order of "identifiers" that indicate whether the particular rate is a union rate (current union negotiated rate for local), a survey rate (weighted average rate) or a union average rate (weighted union average rate).

Union Rate Identifiers

A four letter classification abbreviation identifier enclosed in dotted lines beginning with characters other than "SU" or "UAVG" denotes that the union classification and rate were prevailing for that classification in the survey. Example: PLUM0198-005 07/01/2014. PLUM is an abbreviation identifier of the union which prevailed in the survey for this classification, which in this example would be Plumbers. 0198 indicates the local union number or district council number where applicable, i.e., Plumbers Local 0198. The next number, 005 in the example, is an internal number used in processing the wage determination. 07/01/2014 is the effective date of the most current negotiated rate, which in this example is July 1, 2014.

Union prevailing wage rates are updated to reflect all rate changes in the collective bargaining agreement (CBA) governing this classification and rate.

Survey Rate Identifiers

Classifications listed under the "SU" identifier indicate that no one rate prevailed for this classification in the survey and the published rate is derived by computing a weighted average rate based on all the rates reported in the survey for that classification. As this weighted average rate includes all rates reported in the survey, it may include both union and non-union rates. Example: SULA2012-007 5/13/2014. SU indicates the rates are survey rates based on a weighted average calculation of rates and are not majority rates. LA indicates the State of Louisiana. 2012 is the year of survey on which these classifications and rates are based. The next number, 007 in the example, is an internal number used in producing the wage determination. 5/13/2014 indicates the survey completion date for the classifications and rates under that identifier.

Survey wage rates are not updated and remain in effect until a new survey is conducted.

#### Union Average Rate Identifiers

Classification(s) listed under the UAVG identifier indicate that no single majority rate prevailed for those classifications; however, 100% of the data reported for the classifications was union data. EXAMPLE: UAVG-OH-0010 08/29/2014. UAVG indicates that the rate is a weighted union average rate. OH indicates the state. The next number, 0010 in the example, is an internal number used in producing the wage determination. 08/29/2014 indicates the survey completion date for the classifications and rates under that identifier.

A UAVG rate will be updated once a year, usually in January of each year, to reflect a weighted average of the current negotiated/CBA rate of the union locals from which the rate is based.

---

#### WAGE DETERMINATION APPEALS PROCESS

1.) Has there been an initial decision in the matter? This can be:

- \* an existing published wage determination
- \* a survey underlying a wage determination
- \* a Wage and Hour Division letter setting forth a position on a wage determination matter
- \* a conformance (additional classification and rate) ruling

On survey related matters, initial contact, including requests for summaries of surveys, should be with the Wage and Hour Regional Office for the area in which the survey was conducted because those Regional Offices have responsibility for the Davis-Bacon survey program. If the response from this initial contact is not satisfactory, then the process described in 2.) and 3.) should be followed.

With regard to any other matter not yet ripe for the formal process described here, initial contact should be with the Branch of Construction Wage Determinations. Write to:

Branch of Construction Wage Determinations  
Wage and Hour Division

U.S. Department of Labor  
200 Constitution Avenue, N.W.  
Washington, DC 20210

2.) If the answer to the question in 1.) is yes, then an interested party (those affected by the action) can request review and reconsideration from the Wage and Hour Administrator (See 29 CFR Part 1.8 and 29 CFR Part 7). Write to:

Wage and Hour Administrator  
U.S. Department of Labor  
200 Constitution Avenue, N.W.  
Washington, DC 20210

The request should be accompanied by a full statement of the interested party's position and by any information (wage payment data, project description, area practice material, etc.) that the requestor considers relevant to the issue.

3.) If the decision of the Administrator is not favorable, an interested party may appeal directly to the Administrative Review Board (formerly the Wage Appeals Board). Write to:

Administrative Review Board  
U.S. Department of Labor  
200 Constitution Avenue, N.W.  
Washington, DC 20210

4.) All decisions by the Administrative Review Board are final.

=====

END OF GENERAL DECISION



**APPENDIX B**

**Placer County Department of Public Works Standard  
Details**



DEPARTMENT OF PUBLIC WORKS & FACILITIES  
COUNTY OF PLACER  
**COMMERCIAL DRIVEWAY  
CONNECTION (MAJOR)**

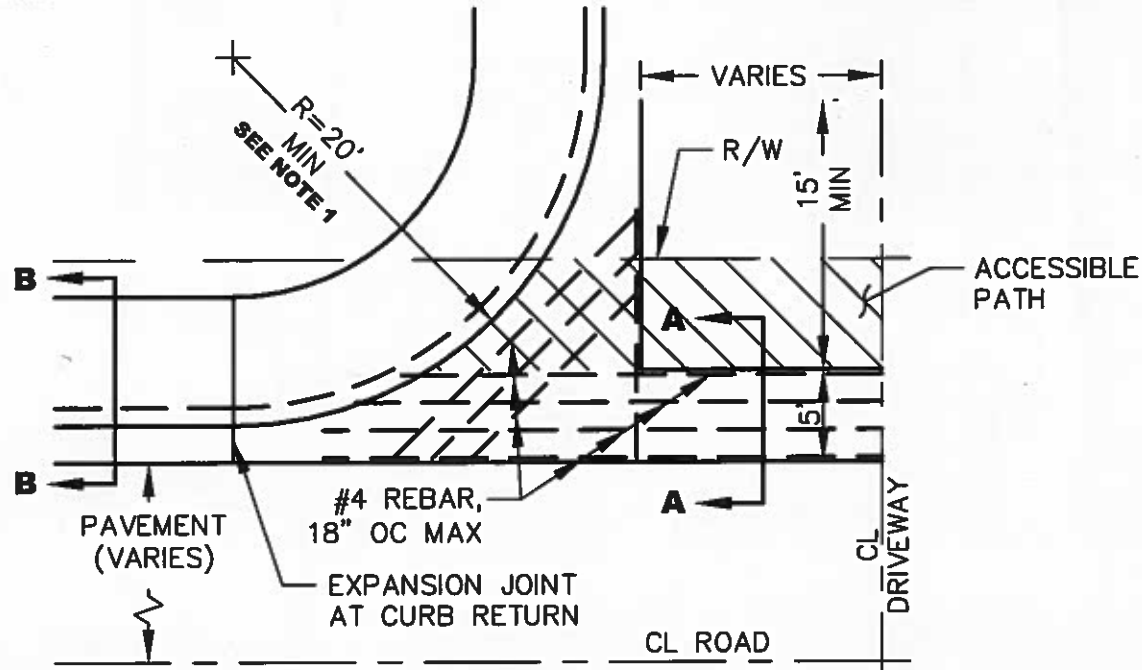

**PLAN VIEW**

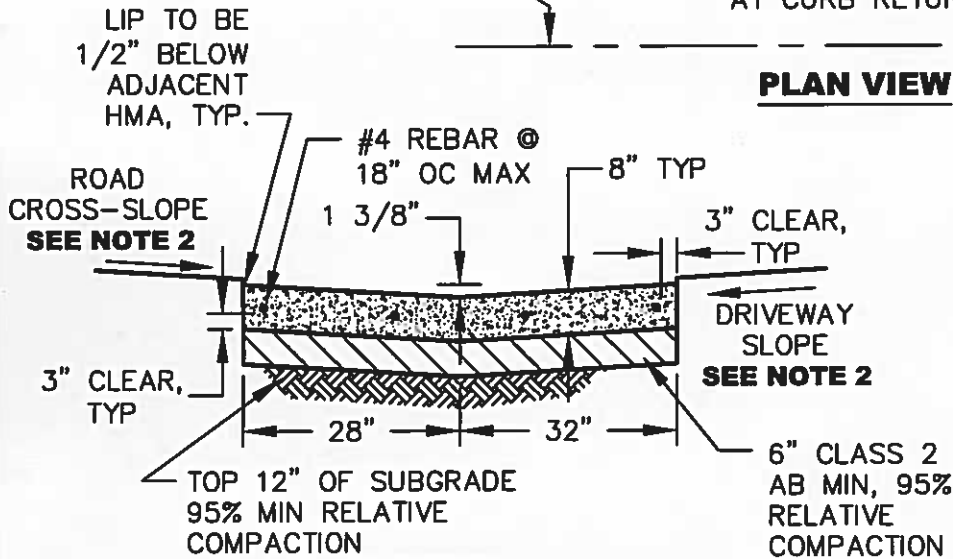

**SECTION A-A  
VALLEY GUTTER**

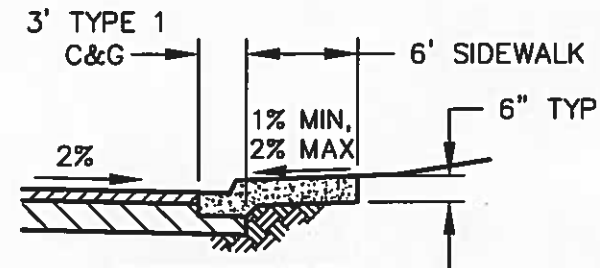

**SECTION B-B**

**NOTES:**

1. THE CURB RETURN RADIUS MAY NEED TO BE LARGER DEPENDING ON THE DRIVEWAY WIDTH, ROAD WIDTH AND THE TYPE OF VEHICLE THAT WILL UTILIZE THE DRIVEWAY.
2. MAXIMUM ALGEBRAIC GRADE DIFFERENCE BETWEEN ROAD CROSS SLOPE AND THE DRIVEWAY SLOPE SHALL BE 5%.
3. SEE APPLICABLE PLACER COUNTY PLATE FOR CURB, GUTTER AND SIDEWALK SPECIFICATIONS.
4. ACCESSIBILITY COMPLIANCE IS REQUIRED. MAXIMUM CROSS SLOPE IS 2% AT DRIVEWAY CROSSING. ACCESSIBLE PATH CANNOT OVERLAP VALLEY GUTTER.
5. ALL PCC TO BE 6-SACK MIX.

DATE:  
APR. 2016  
SCALE:  
NOT TO SCALE



PLATE  
**112**



DEPARTMENT OF PUBLIC WORKS & FACILITIES

COUNTY OF PLACER

**ASPHALT DIKES**

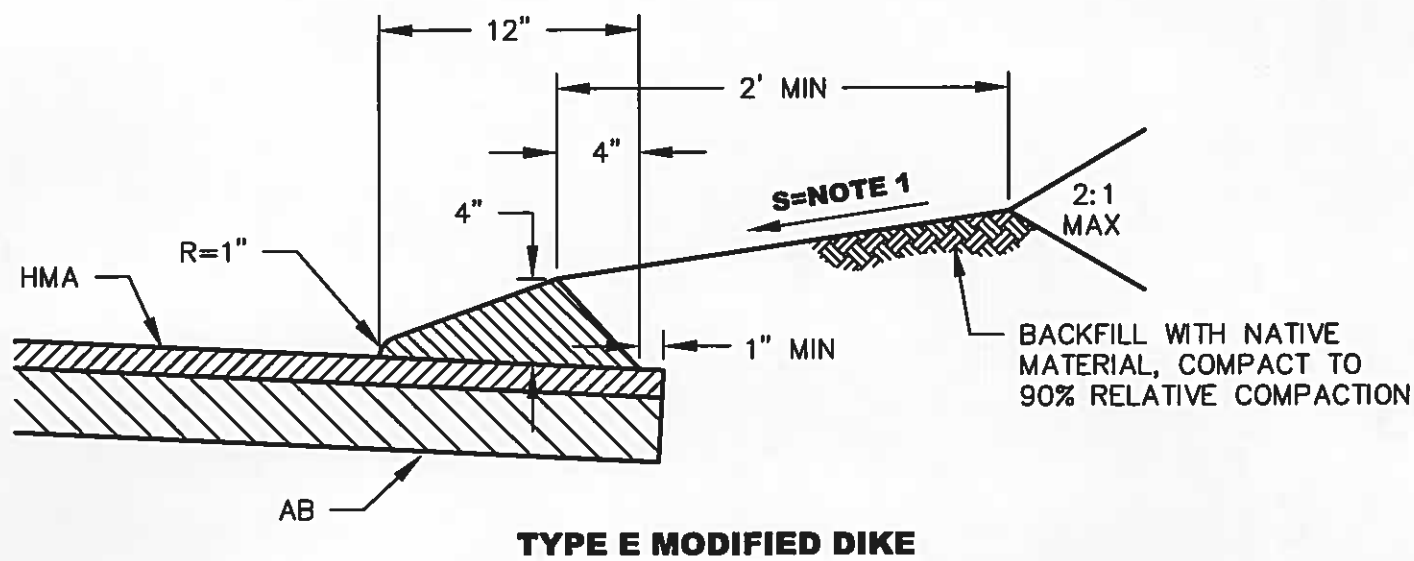
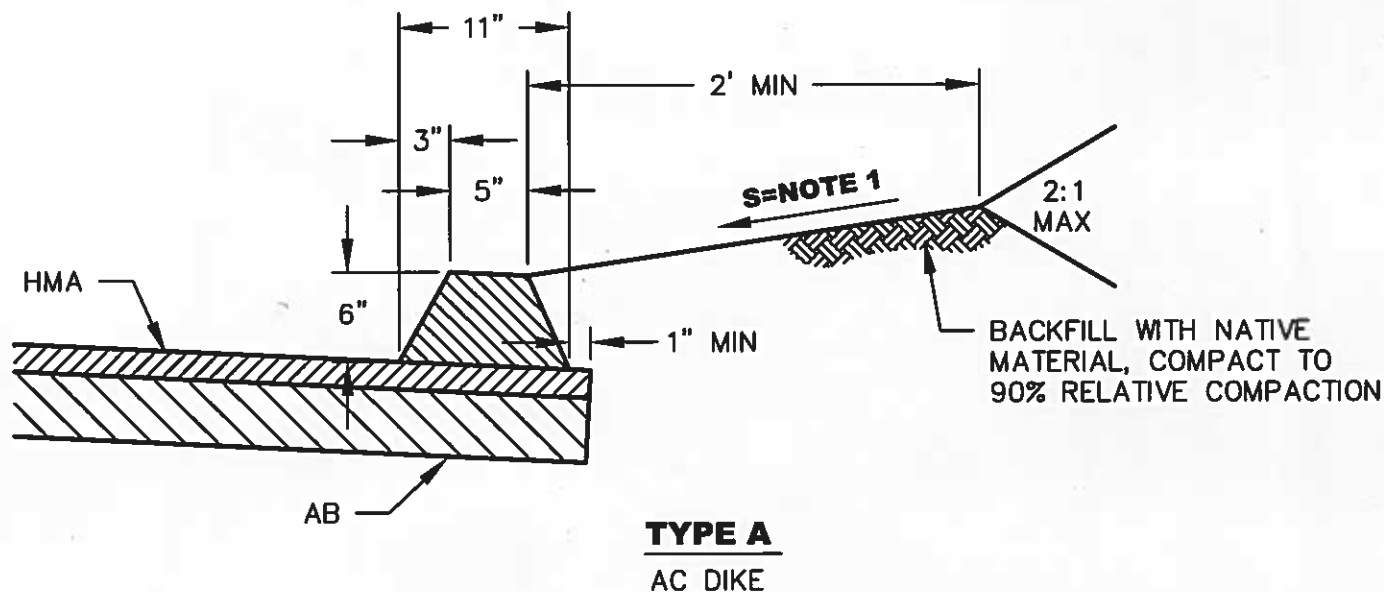

**NOTES:**

1. S=10% MINIMUM SLOPE FOR DIKE BACKFILL. FOR ROADS WITH LONGITUDINAL CENTERLINE SLOPES GREATER THAN 8%, USE 18% MINIMUM AND 22% MAXIMUM DIKE BACKFILL SLOPE.

DATE:  
APR. 2016

SCALE:  
NOT TO SCALE

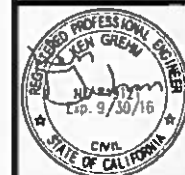

PLATE  
**122**



# Staff Report to City Council

## FOR THE JUNE 26, 2019 REGULAR CITY COUNCIL MEETING

**From:** Wes Heathcock, City Manager  
**Prepared by:** Amy Feagans, City Planner  
**Subject:** Colfax Net Variance to allow a reduced setback to permit installation of a 60-80-foot-high telecommunication tower with antennas

*Budget Impact Overview:*

N/A: ✓	Funded:	Un-funded:	Amount:	Fund(s):
--------	---------	------------	---------	----------

**RECOMMENDED ACTION: Decide whether to grant, grant with modifications, or deny the requested variance.**

### Project Notice:

**Project Title:** Colfax Net Setback Variance  
**Applicant/Owner:** Corey Juchau/Robert Amick  
**Location:** Sierra Sky Court  
**Land Use (existing):** Vacant, undeveloped (Wireless Communication antennas in trees)

### Surrounding Uses

**North:** Large Lot Single family residence  
**South:** Large Lot Single family residence  
**East:** Large lot Single family residence  
**West:** Large lot Single family residence

**Assessor's Parcel Number:** 100-100-030  
**Zoning District:** R-1-10, Single family residential  
**General Plan Designation:** Low density Residential

### Project Background

This item was originally heard at the April 24, 2019 at the end of the testimony, the Council voted to continue the item to the May 22, 2019 meeting. Just prior to May 22 meeting, the applicant requested a continuance to this meeting.

### April 24, 2019 Public Hearing

The Council heard significant amount of public comment in support and some in opposition to the setback variance request. After closing the public hearing, the Council discussed the project at length and then voted to continue the item to the second meeting in May (May 22, 2019) to allow the applicant to provide additional information and to identify other alternatives available.

### Additional Information Requested

The Council asked the applicant to provide the following:

1. Confirmation of approval from PG&E
2. Professional survey of the dead tree
3. Proposed use of new tower space
4. Available options in lieu of the tower

### Response to Council Request

On June 18, 2019, the applicant provided the following information to the City:

1. Letter dated June 18, 2019 outlining other options considered by the applicants (Attachment 1)
2. Letter dated June 18, 2019 providing updated information on correspondence with PG&E, the height of the tree survey, use of tower space and a scope of work. (Attachment 2)

Prior to the May 22, 2019 meeting, the following materials and information were received by staff:

1. PG&E approval: Copies of email correspondence between applicant and PG&E regarding installation of power to the site.
2. Tree survey: Applicant has indicated this will be completed prior to construction of tower. Staff would prefer to have this information prior to the final decision of City Council as the height was a topic of discussion at the last meeting as it relates to the agreement the applicant has with the property owner.
3. Proposed use of tower space: Applicant submitted a list of antennas that will be installed. The plan is to consolidate the antennas that existing not only in the dead tree but also the antennas from the four other trees in the area.
4. Option considered in lieu of the proposed tower: Applicant submitted a list of options considered.

The above four items are included in the May 22 staff report. (Attachment 5)

The applicant also provided the following additional information:

- Proposed scope of work
- A timeline of proposed work - estimated to take five months from issuance of building permit.
- A letter from his attorney, Mr. Monti Reynolds. (Attachment 3)

### Additional Information Received

On June 7, 2019, staff received a letter (Attachment 4) from Attorney Tom Dunipace, attorney for neighbors Tom and Rose Swick.

**Variance Findings**

Colfax Municipal Code Section 17.40.070 G requires the Council to make all of the following findings to approve a variance:

1. There are special circumstances applicable to the property, including size, shape, topography, location or surroundings, such that the strict application of the provisions of this zoning ordinance deprives the property of privileges enjoyed by other property in the vicinity and under identical land use.
2. The granting of the variance does not constitute a grant of special privileges inconsistent with the limitations upon other properties in the vicinity and zone in which the property is located.
3. The granting of the variance does not allow a use or activity which is not otherwise expressly authorized by the regulations governing the subject parcel.
4. The granting of the variance will not be detrimental to the public health, safety or welfare, or injurious to the property or improvements in such vicinity and land use district in which the property is located.

**Environmental Review:**

The project is categorically exempt from CEQA review pursuant to Section 15303 (New Construction or Conversion of Small Structures) of the CEQA Guidelines.

**Staff Recommendation:**

The four options proposed by staff at the last meeting are still appropriate for the variance consideration. Staff recommends the City Council take one of the following actions and direct staff to prepare the appropriate findings to support the decision made:

1. Approve the Variance as requested - findings required
2. Deny the Variance – findings required
3. Approve the Variance with conditions – conditions and findings required
4. Continue the item and request additional information

This item is a semi-judicial action and requires a majority of the full Council (three “yes” votes) to approve any of the actions listed above.

**Attachments**

1. Letter dated 6/18/19 from applicant outlining options considered
2. Letter dated 6/18/19 from applicant proving updated information
3. Letter dated 5/16/19 from R. Monti Reynolds, Reynolds Tilbury Woodward LLP, Attorney for applicant
4. Letter dated 6/7/19 from Thomas M. Dunipace, Attorney for Tom and Rose Swick
5. May 22, 2019 Staff Report to Council with attachments

## Attachment 1

Item 8A

4 of 49



ColfaxNet, LLC  
PO Box 1597  
Colfax, CA 95713  
530.346.8411  
[cs@colfaxnet.com](mailto:cs@colfaxnet.com)

June 18, 2019

Amy Feagans  
City of Colfax Planning Department  
33 S Main Street  
Colfax, CA 95713

Amy:

Here is the list you requested of other options ColfaxNet has considered:

- Inspect property on Colfax Hill to determine feasibility of locating tower at different locations within Mr. Amick's property
  - Found setbacks for a 72' tower only allowed for a small area in the center of the property where the tower could be built. This area has a 100% slope. Colfax City Hillside Development Guidelines do not allow construction on this steep of a slope. This is a unique circumstance that substantiates a variance
  - This location would also require a 1:1 increase in tower height due to the loss of 45' of vertical elevation from proposed tower height. The tower would now need to be approximately 110' tall. This additional height consumes the "allowable" location due to increased setbacks now required.
  - Because this location is over 475' from the proposed location, it would require significant replacement of "broken spokes" in our hub and spoke network due to the significant movement of the proposed location, making in unfeasible.
  
- Lease space on the towers on hill to the South of our easement
  - Feasibility and price quotes received from both tower companies. Found to be cost prohibitive
  - The trees surrounding the towers obscure the line-of-sight directions required at the heights available
  - Would not work without significant reorientation of other sites' antennas
  - Additional site(s) would need to be obtained due to line-of-site restrictions

- Install 3 wooden utility poles in place of metal tower
  - City of Colfax building inspector and Planning Director state that ColfaxNet may not install utility poles without obtaining a building permit. On May 30, 2019, we asked them to provide us with the City ordinance(s) that substantiate their position. We have not yet received a response
  - Size of Utility Pole vertical support structures is significantly larger than proposed metal tower. Utility poles are approximately 10” in diameter at the top and 17” at the bottom. The vertical supports of the proposed tower are only 3”. The utility poles would be more visible and obscure more sky are than metal tower
  - Lattice-style tower will be much closer to a status quo replacement
  - Neighbors were approached, by City officials, with Utility poles as an alternative and they declined to accept
  
- Move Colfax Hill equipment to an entirely different location
  - Would not work without significant reorientation of other sites’ antennas
  - Additional site(s) would need to be obtained due to line-of-site restrictions
  - Cost prohibitive
  - May not be able to obtain backbone connection depending on location of new “hub” site which would require additional sites to repeat signal to main hub
  - Would cause significant interruptions
  
- Four ColfaxNet customers have come forward and offered their property as possible tower sites.
  - We have inspected these properties’ locations and the areas will not work for our purposes
  - One has no power anywhere near the site
  - Two are down in a ravine and do not have line-of-sight to any other ColfaxNet sites than the one they receive signal from
  - One lacks required line-of-sight paths to other sites
  - All of the sites are not able to receive signal directly from our backbone connection and would require additional repeater sites to connect to the backbone

ColfaxNet has previously asserted and, again, feels as though City of Colfax ordinances support ColfaxNet’s authority to install a “replacement” tower or construct a new one without further delays or permissions due to ColfaxNet being defined, among other things, as a “utility” in Colfax City Ordinances and the “Unusual” and “Emergency” “Circumstances” we find ourselves in. For example, Colfax City Ordinances and Definitions-5.16.010 (B), 5.16.020, 5.16.030 (A), (B) and (C), 5.16.050, 5.16.060 (F), 5.16.420, , 5.16.440 (B) (1), 5.16.440 (B)(2), 13.16.010,



## Attachment 1

Item 8A  
6 of 49

13.16.050, 13.16.060, 17.12.030, 17.16.010, 17.64.110, 17.64.110 (A), 17.72.020 (C), 17.132.020 (A), 17.132.020 (B) (1), 17.132.020 (C)(5), (F), Article III.

Also, ColfaxNet maintains that ColfaxNet has a Franchise with the City of Colfax by virtue of the Business License issued by the City of Colfax and ColfaxNet providing “Communication Services” under our “license” issued to us, as defined by the City of Colfax Ordinances, to the residents of Colfax. This Franchise provides for a number of benefits which Colfax has been denied by City officials claiming the definition of the City Ordinances don’t apply to us or our conditions.

ColfaxNet also has brought the concern forward that there is not an alternate Planning Commissioner to fill the position of the Council Member that recused himself. This puts ColfaxNet at a significant disadvantage due to the requirement of ‘yes’ votes of 75% of the remaining members rather than a simple majority.

Please let us know if we can provide any more information.

Thank you,

Corey Juchau  
ColfaxNet Support Group  
[support@colfaxnet.com](mailto:support@colfaxnet.com)  
530.346.8411  
PO Box 1597  
Colfax, CA 95713

## **Attachment 2**

**Item 8A**

**7 of 49**



ColfaxNet, LLC  
PO Box 1597  
Colfax, CA 95713  
530.346.8411  
[cs@colfaxnet.com](mailto:cs@colfaxnet.com)

June 18, 2019

Amy Feagans  
City of Colfax Planning Department  
33 S Main Street  
Colfax, CA 95713

Please find the information you requested in our meeting 4/20/19.

1. PG&E application - please find the enclosed paid preliminary invoice and various correspondence discussing installation of power to tower site. We have located the existing conduits on the parcel. We have met twice with the PG&E Service Planner in the field and determined the location of the meter and future conduits. He collected a number of pictures, drawings and notes to take back to his office. PG&E requires an address to be issued by the City of Colfax. On 4/23/19, we asked the Colfax Building inspector to issue an address for the Sierra Sky parcel. We reminded him on 4/30/19. The project is currently in PG&E's engineering department. As soon as their engineering is completed, they will provide design to us. Our contractor is waiting for PG&E to issue design to bring crews and equipment on site.
2. Height of tree surveyed – The height of the tower has been documented. Due to the variation of ground levels in the area, there is no one location to call the “height” of the tower. The surveyor recommended that the height of the tree be documented using various fixed locations tied together and then tied to a Temporary Benchmark located in a place that will not be disturbed during construction. This Temporary Benchmark will be used as a reference point to ensure height of the tower will be the same as the tree was before construction began. The surveyor spent a day

## **Attachment 2**

**Item 8A**

**8 of 49**

setting points on the hill to fulfill the request of the Council. Someone pulled all of the stakes out ruining the expensive work that was performed. The surveyor had to come back and set a number of key points again that were necessary to document the height of the tree. Although not an absolute “measurement” of the height of the tower, the surveyor set a point that may be used to compare the height of the tower to. It is on the flat area near the tower in the Northeast corner of ColfaxNet’s easement. It is marked with a stake and a yellow ribbon. The tower height will be 66’ higher than this point.

3. Use of tower space - ColfaxNet currently has 23 antennas of various size and shape installed on the hill. These antennas will be painted, a color determined by the Colfax City Planning Director, to blend in with surrounding foliage and relocated to the tower at various heights and directions. Each will be mounted in a location to obscure them as much as possible.
4. Scope of work - please find the enclosed Scope of Work documents
5. Other options considered - please find the enclosed Other Options

Please let us know if we can provide any more information.

Thank you,

Corey Juchau  
ColfaxNet Support Group  
[support@colfaxnet.com](mailto:support@colfaxnet.com)  
530.346.8411  
PO Box 1597  
Colfax, CA 95713

May 16, 2019

Members of the Colfax City Council

Re: **ColfaxNet - Application for Setback Variance**

Ladies and Gentlemen:

Our law firm represents ColfaxNet, Inc., a family business that has supplied high-quality, low-cost wireless internet service to the Colfax community for more than 18 years. The hub of ColfaxNet's wireless network antennas has been located for 15 years in two trees located within 15 feet of one another near the top of Colfax Hill. One of these trees, an approximately 65' pine, has died and is in danger of falling. Should this occur, it is estimated that 350 ColfaxNet customers, a number of whom live in the City of Colfax, immediately will lose internet service. ColfaxNet desires to replace the dead "tree tower" with a metal tower of roughly the same height in the same location, remounting the same antennas used in the dead tree and those near it on Colfax Hill. The dead tree to be replaced is close to a property line. ColfaxNet has requested a variance from setback requirements so that the location of the antennas in the dead tree and the adjacent trees can be replicated on the replacement tower.

Maintaining the near exact location of the antennas now located in the dead tree area is critical to the continued operation of the wireless network that supplies internet services to ColfaxNet's users. The network is based on line-of-sight transmissions and is constructed in a manner similar to a wagon wheel. The dead tree area antennas are the hub of the wagon wheel. The antennas at the end of each spoke of the wheel must be able to "see" the hub antennas in order for the network to function. Line-of-sight requirements are very exacting. A difference of 10 feet one way or another can be the difference between effective transmission and being blocked by a hill, tree or building. Due to the tree covered, hilly topography of Colfax, moving some of the antennas from their current locations by more than a few feet would break spokes in the network wheel.

It has been suggested that ColfaxNet artificially created the need for this variance by obtaining a deeded easement for the proposed tower that would not allow for placement outside the setback zone. First, the deeded easement matches a historic deeded easement of ColfaxNet's that was eliminated due to foreclosure on a previous landowner. It was the only area the current landowner was willing to allow ColfaxNet to occupy. Obtaining an easement elsewhere on the Amick property is a practical impossibility. More importantly,

this line of thinking ignores the unique nature of the dead tree tower location. ColfaxNet is not requesting to replace the tree tower in its exact location because it wants to be near a property line or due to the modest size of its easement on Colfax Hill. It needs to utilize the unique location of the dead tree tower. Even if a much larger easement could have been obtained (which it could not) ColfaxNet would still be seeking the variance to build at this location because it needs to have its antennas at the unique location where the hub can be located without breaking spokes in the wheel.

The only issue before the Council is a setback variance. If ColfaxNet were not tied to the unique location of the dead tree tower, it could build its tower outside a setback area on Colfax Hill without Council approval. The issue is not whether a tower of this type is appropriate on Colfax Hill. The Colfax Municipal Code, in keeping with state and federal law, has already answered that question. This is important to keep in mind because several issues have been raised which speak to the appropriateness of a tower or more accurately antennas. It is easy to lose sight of the one simple issue at hand in the face of emotional appeals speaking to matters already settled.

**A Variance is Appropriate**

The sole issue before the Council is whether a setback variance is appropriate to allow the tower location ColfaxNet needs. As we will show, a variance is appropriate.

**Variations and use permits are means of providing administrative relief from, or flexibility in, the application of zoning ordinances and regulations.** Most zoning laws are inherently of broad application, and are generally required to be uniform. (*cite omitted*). Variations, conditional use permits, and other administrative exceptions allow local governments to adjust zoning regulations or to provide site-specific regulations, consistent with the adopted zoning ordinance, **to avoid hardships or to achieve other appropriate goals**, without going to the extent of legislatively amending the zoning ordinance. See *Topanga Ass'n for a Scenic Community v County of Los Angeles* (1974) 11 C3d 506, 511. (*Lindgren & Matta, California Land Use Practice (2019), Section 7.19 emphasis added*)

In short, variations are a tool which gives the City Council the flexibility to prevent hardship or achieve other appropriate goals. As shown above, relocating the antenna away from the site of the dead tree tower will “break spokes” in the line of site network. This will result in hardship to numerous parties. Broken spokes will mean loss of internet service to some ColfaxNet users. If the break can be repaired by the installation of additional antenna towers and if ColfaxNet elects to install such towers, that disruption may be temporary. If new towers are not installed, the service loss will be permanent, resulting in hardship to the users and economic hardship to ColfaxNet. It is unclear if ColfaxNet could survive the additional expense of mending the “broken spokes” with new towers or losing the users, potentially resulting in the demise of the company, economic hardship to its owners and employees and loss of the best low cost internet service for all of its users in and outside of Colfax. (Note courts have affirmed local variations on the basis of factors tending to show purely economic hardship in the absence of relief. See,

### Attachment 3

*e.g., Zakessian v City of Sausalito (1972) 28 CA3d 794, 799*) If ColfaxNet can withstand the economic cost of additional towers, it may need to raise rates, causing a hardship on users. Perhaps most important, the new towers required to fix the breaks may have their own impacts. Will residents near these new towers raise complaints?

Granting the variance is the best choice to preserving the status quo: good low-cost wireless internet to Colfax residents and their neighbors; keeping ISP prices in check through maintaining competition and allowing a choice of ISPs, and retaining a locally based, locally focused company. Variances exist so that useful goals such as these can be achieved and hardships avoided.

Against these goals, the council should consider any hardships on the surrounding landowners. Because the only material change to the status quo is substituting a metal tower for a dead tree, the only change (and arguable hardship) is a visual one. As we will demonstrate below, that “hardship” is minor.

#### Necessary Findings

In order to grant ColfaxNet’s variance, the Colfax Municipal Code states that the Council should make four findings. ColfaxNet’s request for variance allows for each of these findings. They will be discussed individually below.

**Finding No. 1** *There are special circumstances applicable to the property, including size, shape, topography, location or surroundings, such that the strict application of the provisions of this zoning ordinance deprives the property of privileges enjoyed by other property in the vicinity and under identical land use.*

As stated above, there are special circumstances with respect to this particular site location. This unique site is the hub of a complex existing line-of-sight network designed to account for the unique tree-covered, hilly topography of Colfax Hill and the greater Colfax community. If the tower were moved as much as 10 feet in any direction, one or more of the spokes of the wagon wheel network would be broken. While a broken spoke might be repairable if an additional tower was erected that has line-of-sight between the relocated hub and the end of the spoke node, this solution would only contribute to a greater proliferation of antennas and towers.

The second special circumstance that should be considered is the previous existence of a tree tower in the identical location. The tower has occupied this exact site for more than 15 years. The only material change from the status quo is the replacement of a wooden structure, in the form of a tree, with a metallic structure. Benefits and burdens to all parties will remain unchanged except for a minor visual change. This is itself a special circumstance. In no other location will the status quo be so preserved.

A third special circumstance is the slope and vegetation of the property in question. If we were to assume ColfaxNet could obtain an easement anywhere on the Amick property (which it cannot) and if we were to accept the broken spokes in the network that relocation

would necessitate (which would cause severe hardship), the slope and vegetation of the Amick property would still make obtaining a suitable antenna height nearly impossible. The requested site is practically the highest point on the property. Each foot of elevation drop requires an increase of antenna height by a foot and a corresponding increase in the set back of two feet. The result is little or no footprint in the middle of the Amick property where a very tall antenna would need to be located. I suspect the neighbors would prefer a small tower nestled in the tree line to an Eifel tower towering above it from the middle of the property. This would justify a variance if the entire Amick property were in play. However, as a practical matter, access to any other site on the Amick property is unavailable.

**Finding No. 2** *The granting of the variance does not constitute a grant of special privileges inconsistent with the limitations upon other properties in the vicinity and zone in which the property is located.*

Properties of this zoning classification are allowed to have towers of this type. Granting a variance allowing the otherwise permitted tower to be built closer to a property line does not give this property a special privilege because other properties in the vicinity with similar zoning are allowed to have similar towers.

**Finding No. 3** *The granting of the variance does not allow a use or activity which is not otherwise expressly authorized by the regulations governing the subject parcel.*

There is no prohibition against having this tower for the purposes requested on the subject property. As such, the granting of the variance will not allow activity which is not otherwise expressly authorized.

**Finding No. 4** *The granting of the variance will not be detrimental to the public health, safety or welfare, or injurious to the property or improvements in such vicinity and land use district in which the property is located.*

Allowing the variance will not be detrimental to the public health or safety. The project maintains the status quo with the exception of exchanging wood for steel so public health and safety will be unaffected other than the positive effect of eliminating a tree that is in danger of falling.

Allowing the variance will not be detrimental to the welfare of the people of Colfax or injurious to property or improvements. If we discount the possibility for property damage posed by the dead tree tower, the only arguable impact on welfare or property is visual. The tower in question will not be noticeable from almost all of Colfax. By way of illustration, I would challenge anyone to spot the current antennas on the dead tree tower from any location other than Sierra Sky Court. The antenna can be seen from at least one place in downtown Colfax, specifically the parking lot of the US Bank building. It is a tiny dot of white buried in the tree line. It is miniscule compared to the three massive antennas located elsewhere on the ridge. Now imagine if that tiny white dot were painted a color

blending with the trees. For practical purposes, this installation should be difficult to spot from anywhere other than Colfax Hill.

The parties that will potentially see the tower are the residents of three properties located on Sierra Sky Court at the top of Colfax Hill. However, the tower should not be visible from any of these parties' residences. The only time when they would see the tower is while driving or walking on an approximately 100-yard stretch of road running directly beneath the tower. Even then, the visual impact will be minimized because, for most drivers, as the viewing angle to see the tower will be so great that it will be blocked by the roof of most automobiles. Realistically, the tower will only be viewed by drivers in convertibles and persons walking on the road below who will be able to look up at a very high angle.

Opponents to the tower have shown photos of the antennas in and around the existing dead tree which make the antennas appear large and obtrusive. Fortunately, these pictures were taken from locations where no human will ever be. They are close-up drone shots taken from a height of over 60 feet above the ground or 70 feet above the road nearest to the tower. As a result, the visual impact suggested by the photos is grossly misleading.

Considering impacts to public health, safety and welfare cannot be complete without considering the positive impacts contributed by this tower. As stated above, this tower is integral to the ColfaxNet network. That network is instrumental in providing useful public information at a low cost to the citizenry of Colfax and their neighbors beyond the city limits. In the case of some persons, ColfaxNet's service is their only available internet service. For others, ColfaxNet is the low-cost quality provider, without which, they might not be able to afford internet service. In many cases, ColfaxNet is the only alternative to its competitors. The demise of ColfaxNet would result in virtual monopolies for competitive internet service in certain areas of Colfax removing the benefits of healthy competition and lower prices for the members of the Colfax community.

**All Those Other Issues**

The matter before the City Council is a simple variance request. It has been complicated by the emotional appeals of a handful of persons who have raised a number of irrelevant issues. I do not want to burden the Council or encourage the misdirection. Nonetheless a brief response may be helpful. Reserving the right to respond in more detail at a later date, let me address a few of the extra issues in outline form:

- Issue: Neighbors will have increased radiation exposure if the variance is granted.
  - The antennas have been in place for 14 years. All that is changing is what is holding the antennas.
  - Similar Towers and antennas are permitted by the zoning on Colfax Hill.
  - Radiation from the antennas is low and dissipates very rapidly based on the inverse square law.



- The relative harmlessness of antennas is recognized by federal, state and local laws allowing antennas to be placed almost anywhere.
- The adjoining neighbor's residence is more than 400' from the existing antenna site.
- The party allegedly most concerned with radiation maintains a directional antenna on his property that directs far more radiation to his residence than the ColfaxNet antennas.
  
- Issue: ColfaxNet is getting free land.
  - ColfaxNet negotiated and paid for a deeded easement for this site prior to Mr. Amick's ownership. Through no fault of ColfaxNet, the deeded easement was wiped out by foreclosure on a previous property owner, leaving ColfaxNet with prescriptive rights.
  - ColfaxNet negotiated and must pay Mr. Amick \$15,000 for the current deeded easement. (It has bought and paid for the easement twice.)
  - In the past ColfaxNet has provided cash, free internet and other concessions for locating its antennas on other sites.
  
- Issue: There are construction and utility service issues.
  - Code compliance will be enforced by the Building Department which will monitor construction.
  
- Issue: ColfaxNet's existing tree towers on Colfax Hill were improperly permitted.
  - No permits were obtained because no permits were required for these types of installations.
  
- Issue: The owner of the Amick property's rights would be violated by the variance.
  - ColfaxNet has agreements with the Amick property owner that contemplate the granting of the variance.
  - Should ColfaxNet violate its agreements, the property owner is well represented and can enforce its agreements without concerning the City of Colfax.
  
- Issue: The neighboring property owner's rights would be violated by the variance.
  - ColfaxNet's proposal seeks to preserve the status quo. It is only changing its antenna support from wood to steel. The change does not violate any property rights.
  - If the neighboring owner believes the existing status quo to be improper, it may address its concerns with ColfaxNet directly without involving the City of Colfax.

There is a common theme as to why these extraneous arguments are invalid. All we are proposing is replacing a wooden tree with a metal one. Maintaining the status quo harms no one.

**Conclusion**

For the reasons stated above, we respectfully request that the City Council approve the variance on behalf of ColfaxNet.

Should any members of the City Council or City Staff have any questions regarding this matter or if there is any information that can be provided to further assist in the process, please do not hesitate to contact our offices.

REYNOLDS TILBURY WOODWARD LLP

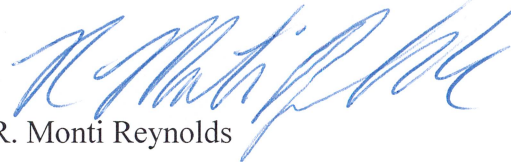

R. Monti Reynolds

**Thomas M Dunipace**  
**Attorney at Law**  
1150 Stone Hearth Lane  
Lincoln, CA 95648  
June 7, 2019

**Members of the Colfax City Council**

**Re: Application for Variance by Colfax Net**

I represent Tom Swick, the adjoining landowner to the property of Robert Amick.

This request for a Variance should be denied for the following reasons:

First: **Lack of Standing**. The applicant, Corey Juchau, owner of Colfax Net, lacks standing to apply for a variance on the real property of Robert Amick, owner of APN 100-100-030. A variance runs with the land. There is no provision governing the granting of a variance based upon an easement. Robert Amick must be the entity seeking a variance and in these circumstances a variance is not needed for Robert Amick as he does not have special circumstances applicable to his property that deprives him the privileges of other property in the vicinity.

Second: **Regulatory Taking of Property**. Should the City approve this application, they have in essence taken the setback required by the City Code by burdening the adjoining land owner via regulatory action. There is no procedure for the taking of property via the variance process. The City has other powers that they can elect to use to initiate a condemnation action wherein Mr. Swick will be entitled to receive just compensation. The proposed tower has a diminishing monetary impact upon his property and restricts him in enjoying the current and future use of his land.

Third: **Hardship Must Relate to the Land**. The applicant offers no evidence of hardship to the parcel in the variance request. There must be a nexus between the variance requested and the hardship impacting the subject property. The applicant relies upon a commercial hardship to themselves and others but this does not rise to the required special circumstances applicable to the specific parcel.

In summary, not to minimize the conundrum facing Colfax Net, this request for a variance is not the appropriate vehicle to achieve their goals.

Respectfully,



Tom Dunipace

(530) 278-8314 [tdunipace@gmail.com](mailto:tdunipace@gmail.com) SB# 99222



# Staff Report to City Council

## FOR THE MAY 22, 2019 REGULAR CITY COUNCIL MEETING

**From:** Wes Heathcock, City Manager  
**Prepared by:** Amy Feagans, Planning Director  
**Subject:** Colfax Net Variance to allow a reduced setback to permit installation of a 60-80-foot-high telecommunication tower with antennas

*Budget Impact Overview:*

N/A: <input checked="" type="checkbox"/>	Funded:	Un-funded:	Amount:	Fund(s):
--	---------	------------	---------	----------

**RECOMMENDED ACTION: Review and discuss the options and take final action.**

**Project Notice:**

Project Title: Colfax Net Setback Variance  
 Applicant/Owner: Corey Juchau/Robert Amick  
 Location: Sierra Sky Court  
 Land Use (existing): Vacant, undeveloped (Wireless Communication antennas in trees)

Surrounding Uses

North: Large Lot Single family residence  
 South: Large Lot Single family residence  
 East: Large lot Single family residence  
 West: Large lot Single family residence

Assessor's Parcel Number: 100-100-030  
 Zoning District: R-1-10, Single family residential  
 General Plan Designation: Low density Residential

**Project Background**

**Project Request:**

The applicant, Corey Juchau owner of Colfax Net, applied for a variance from section 17.132.030- A9 of the zoning ordinance to construct a maximum 80-foot high telecommunications tower within 10 feet of the property line instead of the 160-foot setback the zoning code requires for an 80-foot tower. If the variance is approved, a new tower will replace a dead tree that is currently housing the Colfax Net antennas to provide internet service to Colfax Net customers (refer to Attachment 1). The site is located on Sierra Sky Court, near the top of the ridge on Beacon Hill. The applicant has a recorded easement that allows him use of an approximately 50' by 50' section in the northwest corner of an 8.5-acre parcel adjacent to two residential parcels. A map showing the general location of the dead tree and the proposed location of the tower is attached as Attachment 2. The easement language is very specific and was granted for "the purpose of locating, constructing, operating and maintaining communication facilities

owned or operated by the grantee.” (See attachment 3). The applicant does not have the right to construct a tower outside the easement area. Because the easement is located near the corner of the parcel, the applicant is seeking approval of a variance to allow for a substandard setback from property lines so the tower can be constructed within the easement boundaries.

### **April 24, 2019 Public Hearing**

This project was originally heard as a public hearing at the April 24, 2019 City Council meeting. At that meeting there was significant amount of public comment both in support of and opposition to the setback variance. After closing the public hearing, the Council discussed the project at length and then voted to continue the item to the second meet in May 2019 to allow the applicant to provide additional information and to identify other alternatives available.

### **Additional Information Requested**

The Council asked the applicant to provide the following:

1. Confirmation of approval from PG&E
2. Professional survey of the dead tree
3. Proposed use of new tower space
4. Available options in lieu of the tower

### **Response to Council Request**

The applicant, Corey Juchau has provided the following materials and information in response to the Council’s request at the last meeting:

1. PG&E approval: Copies of email correspondence between applicant and PG&E regarding installation of power to the site. (Attachment 4)
2. Tree survey: Applicant has indicated this will be completed prior to construction of tower. Staff would prefer to have this information prior to the final decision of City Council as the height was a topic of discussion at the last meeting as it relates to the agreement the applicant has with the property owner.
3. Proposed use of tower space: Applicant submitted a list of antennas that will be installed. The plan is to consolidate the antennas that existing not only in the dead tree but also the antennas from the four other trees in the area. (refer to attachment 5)
4. Option considered in lieu of the proposed tower: Applicant submitted a list of options considered. (refer to attachment 6)

The applicant also provided the following additional information:

- Proposed scope of work (Attachment 7)
- A timeline of proposed work - estimated to take five months from issuance of building permit. (Attachment 8)
- A letter from his attorney (Attachment 9)

**Variance Findings**

Colfax Municipal Code Section 17.40.070 G requires the Council to make all of the following findings to approve a variance:

1. There are special circumstances applicable to the property, including size, shape, topography, location or surroundings, such that the strict application of the provisions of this zoning ordinance deprives the property of privileges enjoyed by other property in the vicinity and under identical land use.
2. The granting of the variance does not constitute a grant of special privileges inconsistent with the limitations upon other properties in the vicinity and zone in which the property is located.
3. The granting of the variance does not allow a use or activity which is not otherwise expressly authorized by the regulations governing the subject parcel.
4. The granting of the variance will not be detrimental to the public health, safety or welfare, or injurious to the property or improvements in such vicinity and land use district in which the property is located.

**Environmental Review:**

The project is categorically exempt from CEQA review pursuant to Section 15303 (New Construction or Conversion of Small Structures) of the CEQA Guidelines.

**Staff Recommendation:**

The four options proposed by staff at the last meeting are still appropriate for the variance consideration. Staff recommends the City Council take one of the following actions and direct staff to prepare the appropriate findings to support the decision made:

1. Approve the Variance as requested - findings required
2. Deny the Variance – findings required
3. Approve the Variance with conditions – conditions and findings required
4. Continue the item and request additional information

This item is a semi-judicial action and requires a majority of the full Council (three “yes” votes) to approve any of the actions listed above.

**Attachments**

1. Photograph of existing dead tree with antennas
2. Site Plan
3. Easement language
4. Email correspondence with PG&E
5. Proposed use of tower space
6. Options considered
7. Proposed scope of work
8. Timeline of proposed work
9. Letter dated 5/16/19 from R. Monti Reynolds, Reynolds Tilbury Woodward LLP, Attorney for applicant
10. Location/parcel map

Photograph of existing dead tree with antennas

Picture of existing equipment in dead tree to be relocated to new tower.

Robert Amick/ColfaxNet

a portion of PM 18-43 & Lot Line Adjustment 06-06

530.346.8411

Tower installation

APN 100-100-30



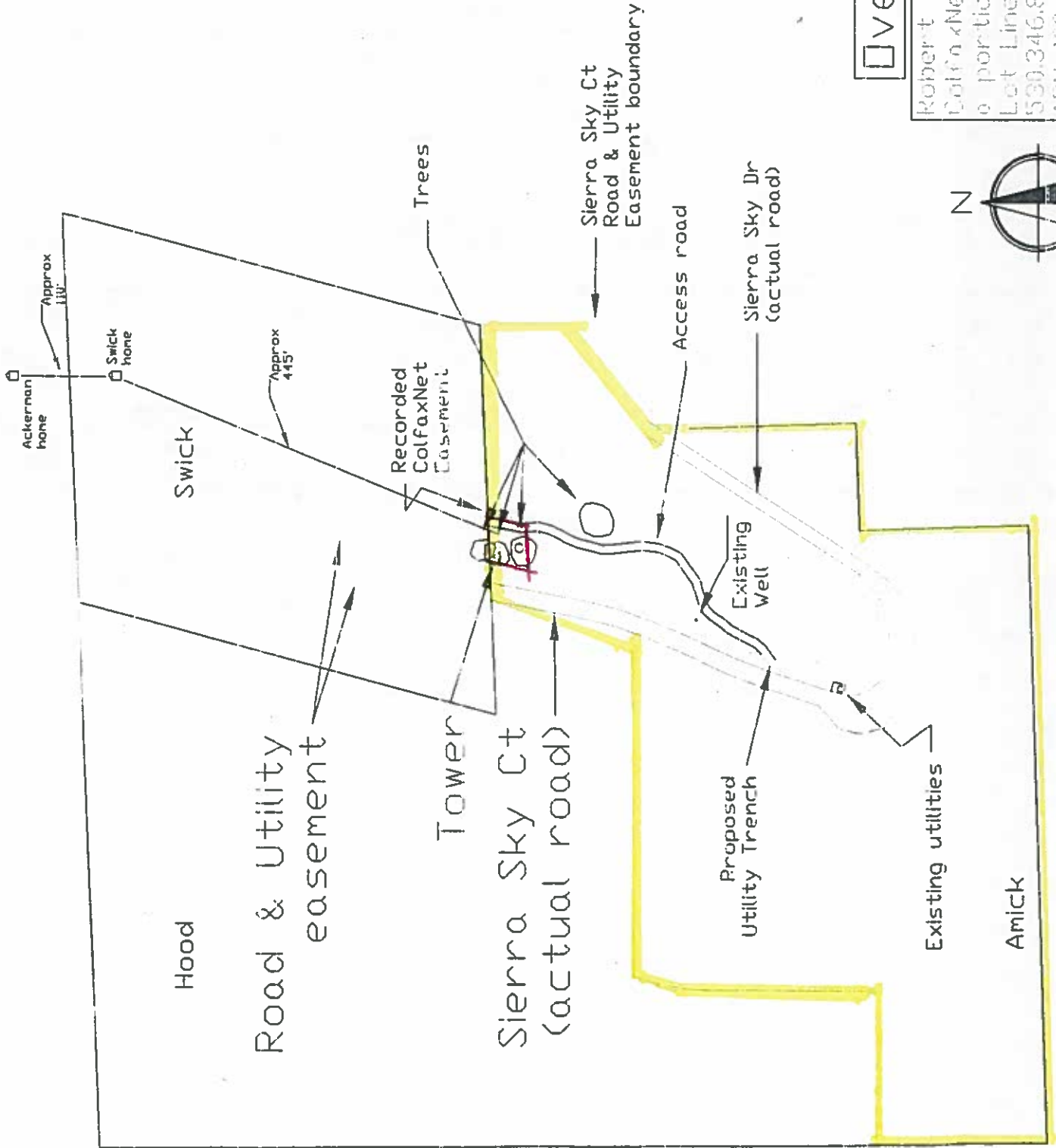

Overview Map

Robert Amick/  
 ColfaxNet Tower installation  
 a portion of PM 18-43 &  
 Lot Line Adjustment 06-06  
 530.346.8411  
 APN 100-100-30



Easement Language

PLACER, County Recorder  
RYAN RONCO  
DOC- 2018-0072343-00

Item 8A  
22 of 49

RECORDING REQUESTED BY  
AND WHEN RECORDED MAIL TO:

ColfaxNet  
P.O. Box 1597  
Colfax, CA 95713

TUESDAY, OCT 9, 2018 8:14:15  
MIC \$3.00 | AUT \$3.00 | SBS \$2.00  
ERD \$1.00 | SB2 \$75.00 | REC \$11.00  
ADD \$0.00

Ttl Pd \$95.00 Rcpt # 02726096  
CLK98CT282/SG/1-3

*Transfer Tax \$ Zero*

SPACE ABOVE THIS LINE FOR RECORDER'S USE

EASEMENT DEED

This agreement is made and entered into this twenty-sixth day of June, 2018 by Robert E. Amick, as Trustee of the Amick Family Trust, Dated December 10, 1990 (hereinafter "GRANTOR"), being the owner of the property described as APN 100-100-025 ("Servient Estate"), and ColfaxNet (hereinafter "GRANTEE").

In exchange for valuable consideration, receipt of which is hereby acknowledged, GRANTOR grants to GRANTEE, its heirs, administrators, executors, successors and assigns, an easement appurtenant to:

A portion of Parcel B as shown on that certain Parcel Map recorded in Book 18 of Parcel Maps, at Page 43, Records of Placer County, described as follows:

Beginning at a point on the south line of Parcel C as shown on said Parcel Map, from which the southwest corner of said Parcel C bears along said south line South 89°57'53" West 233.66 feet; thence from said point of beginning leaving said south line parallel with the east line of an easement 50 feet in width as described in Document No. 2003-023666, Records of Placer County, South 16°38'34" West 50.00; thence parallel with said south line of Parcel C South 89°57'53" West 55.00 feet to a point on the east line of said easement; thence along said east line North 16°38'34" East 50.00 feet to a point on the south line of said Parcel C; thence along said south line North 89°57'53" East 55.00 feet to the point of beginning.

The parties incorporate by reference the maps and legal descriptions set forth in Exhibits A and B of Document 2005-0164796, Records of Placer County, as if set forth fully herein. The property granted to GRANTEE shall be referred to as the Dominant Estate.

The easement granted herein is for the purpose of locating, constructing, operating and maintaining communication facilities owned or operated by GRANTEE, its heirs, administrators, executors, successors and assigns. Said communications facilities may include, but are not limited to, towers, equipment buildings (non-residential) and utility access to service said facilities.

Said easement is intended to occupy the same area as the easement set forth in Document 2005-0164796, Records of Placer County, with the understanding that the easement is of sufficient

Easement Language

size to allow use by both ColfaxNet and the California Division of Forestry. The easement to GRANTEE, herein, runs with the land and exists independently of the easement set forth in Document 2005-0164796, Records of Placer County, without regard to whether the prior easement is extinguished.

GRANTEE shall have the right to use any existing roadway on the servient estate to access the property conveyed by this Easement Deed.

The GRANTEE hereby agrees to hold and save the GRANTOR harmless from any and all claims, liability and damages arising from the GRANTEE's use, possession and occupancy of the real property as herein granted and hereby further agrees to pay for any such damages.

This Easement Deed and all obligations set forth herein shall be an easement appurtenant binding upon and inure to the benefit of the parties hereto, and their respective heirs, administrators, executors, successors and assigns and shall run with the land.

[Signature]  
Robert E. Amick, as Trustee  
of the Amick Family Trust,  
Dated December 10, 1990, GRANTOR

9/26/18  
Dated

[Signature]  
Lynele Lachau, ColfaxNet, GRANTEE

10/5/18  
Dated

A notary public or other officer completing this certificate verifies only the identity of the individual who signed the document to which this certificate is attached, and not the truthfulness, accuracy, or validity of that document.

STATE OF CALIFORNIA )  
 ) ss.  
COUNTY OF PLACER )

On Sept. 26, 2018, before me, Pam Burns, Notary Public, personally appeared Robert E. Amick who proved to me on the basis of satisfactory evidence to be the person(s) whose name(s) is/are subscribed to the within instrument and acknowledged to me that he/she/they executed the same in his/her/their authorized capacity(ies), and that by his/her/their signature(s) on the instrument the person(s), or the entity upon behalf of which the person(s) acted, executed the instrument.

I certify under PENALTY OF PERJURY under the laws of the State of California that the foregoing paragraph is true and correct.

WITNESS my hand and official seal  
[Signature]  
SIGNATURE





Easement Language

# All-purpose Acknowledgment California only

A notary public or other officer completing this certificate verifies only the identity of the individual who signed the document to which this certificate is attached, and not the truthfulness, accuracy, or validity of that document.

State of California

County of Placer

On 10/5/18 before me, Michael Kelderman, Notary Public (here insert name and title of the officer),

personally appeared Lynelle Suchau

who proved to me on the basis of satisfactory evidence to be the person(s) whose name(s) is/are subscribed to the within instrument and acknowledged to me that he/she/they executed the same in his/her/their authorized capacity(ies), and that by his/her/their signature(s) on the instrument the person(s), or the entity upon behalf of which the person(s) acted, executed the instrument.

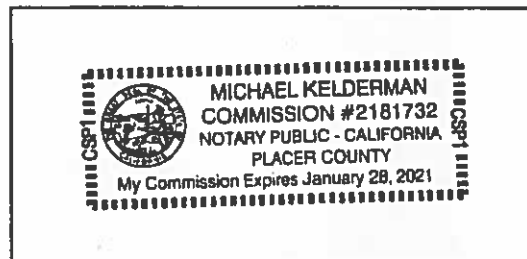

Notary Seal

I certify under PENALTY OF PERJURY under the laws of the State of California that the foregoing paragraph is true and correct.

WITNESS my hand and official seal.

Signature [Handwritten Signature]

**For Bank Purposes Only**

Description of Attached Document

Type or Title of Document Easement Deed

Document Date 9/26/18 Number of Pages 2

Signer(s) Other Than Named Above Robert E Anick



Subject: Re: Sierra Sky Court, Colfax / PG&E Application 116391856  
From: ColfaxNet Support <support@colfaxnet.com>  
Date: 3/26/2019, 11:30 AM  
To: "Finato, Aaron" <AMFg@pge.com>  
CC: support@colfaxnet.com

Hi Aaron:

Would you please let us know when we can speak about or meet at the Sierra Sky Ct?

Thank you,

Corey

--

Corey Juchau  
ColfaxNet Support Group  
PO Box 1597  
Colfax, CA 95713  
530.346.8411  
[support@colfaxnet.com](mailto:support@colfaxnet.com)

On 3/21/2019 8:44 PM, ColfaxNet Support wrote:

Hi Aaron:

Now that you have returned, we hope to speak with you. We have had the the property surveyed and changes to the location of the meters are likely. Can we schedule a time to meet at the site to discuss the latest information and how you would like us to position the power meter(s).

Thank you,

Corey

On 3/13/2019 7:11 PM, Aaron Finato wrote:

I will be out of the office, returning Tuesday, March 19th. I will not have access to e-mail or voicemail.

If you do not hear from me within 1 business day upon my return or your matter is urgent, please e-mail my supervisor Dave Bond at [D5BP@pge.com](mailto:D5BP@pge.com) or contact him at 530-613-9158.

Thank you,

**Aaron Finato** | Sr. New Business Representative  
Pacific Gas and Electric Company  
Service Planning

12840 Bill Clark Way                      Email correspondence with PG&E  
Auburn, CA 95602  
Phone: 530.889.3256  
Cell: 530.559.7849  
E-mail: [amfg@pge.com](mailto:amfg@pge.com)

On 3/13/2019 7:11 PM, ColfaxNet Support wrote:

Hi Aaron:

We are finalizing the permits with the City of Colfax for the service at Colfax Hill.

We had the easement property surveyed today and have some questions on where best to place the meter.

the location you and us were thinking that we could install it will not work.

Would you have some time to come to the site and recommend a location for us?

Please let us know when you have a chance.

Thank you,

Corey

--

Corey Juchau  
ColfaxNet Support Group  
PO Box 1597  
Colfax, CA 95713  
530.346.8411  
[support@colfaxnet.com](mailto:support@colfaxnet.com)

On 3/7/2019 1:41 PM, Finato, Aaron wrote:

Thanks Corey. Please keep me posted on the address from the city of Colfax.

Thank you,

**Aaron Finato** | Sr. New Business Representative  
Pacific Gas and Electric Company  
Service Planning  
12840 Bill Clark Way  
Auburn, CA 95602  
Phone: 530.889.3256  
Cell: 530.559.7849  
E-mail: [amfg@pge.com](mailto:amfg@pge.com)

Email correspondence with PG&E

**From:** ColfaxNet Support <[support@colfaxnet.com](mailto:support@colfaxnet.com)>  
**Sent:** Thursday, March 07, 2019 12:16 PM  
**To:** Finato, Aaron <[AMFg@pge.com](mailto:AMFg@pge.com)>  
**Cc:** [support@colfaxnet.com](mailto:support@colfaxnet.com)  
**Subject:** Re: Sierra Sky Court, Colfax / PG&E Application 116391856

Hi Aaron:

Thank you for your time Tuesday and the information.

Yes, we want to move forward with the project.

We're finishing up the building permit with the City of Colfax and we should be good to go.

Thanks again,

Corey

On 3/7/2019 10:58 AM, Finato, Aaron wrote:

Hi Corey,

Per our meeting onsite here are the items we discussed:

- The required PG&E enclosure will be: 17" x 30" x 26" (PG&E Code: 040929)
- Post Mounted Service construction requirements attached.
- Your electric panel must have "Test-Bypass" studs per PG&E Greenbook Standard, Section 7, Note 7.2.2. [PG&E Greenbook](#)

Please let me know if we're going to proceed with the plan discussed in the field. Lastly, let me know if you have any questions.

Thanks,

**Aaron Finato** | Sr. New Business Representative  
Pacific Gas and Electric Company  
Service Planning  
12840 Bill Clark Way  
Auburn, CA 95602  
Phone: 530.889.3256  
Cell: 530.559.7849  
E-mail: [amfg@pge.com](mailto:amfg@pge.com)



Virus-free. [www.avg.com](http://www.avg.com)

--

Corey Juchau                      Email correspondence with PG&E  
ColfaxNet Support Group  
PO Box 1597  
Colfax, CA 95713  
530.346.8411  
[support@colfaxnet.com](mailto:support@colfaxnet.com)

--

Corey Juchau  
ColfaxNet Support Group  
PO Box 1597  
Colfax, CA 95713  
530.346.8411  
[support@colfaxnet.com](mailto:support@colfaxnet.com)

Email correspondence with PG&amp;E

**Subject:** Re: Document 065374  
**From:** ColfaxNet Support <support@colfaxnet.com>  
**Date:** 4/13/2019, 10:27 AM  
**To:** "Finato, Aaron" <AMFg@pge.com>  
**CC:** support@colfaxnet.com

Aaron:

I'll hit the city up again for the address. We already uploaded a copy of our easement that was recorded with Placer County to the PG&E web site. This easement is with the property owner which gives us authority for access and to install utilities, towers and related equipment. What more do you need than a recorded easement? Please let me know and I'll do what I can.

Thanks,

Corey

On 4/13/2019 6:18 AM, Finato, Aaron wrote:

Corey,

I still need the following in order to move this project into estimating.

- Written agreement of right to occupy property.
- Address for parcel in writing from City/County.

Thanks,

**Aaron Finato** | Sr. New Business Representative  
Pacific Gas and Electric Company  
Service Planning  
12840 Bill Clark Way  
Auburn, CA 95602  
Phone: 530.889.3256  
Cell: 530.559.7849  
E-mail: [amfg@pge.com](mailto:amfg@pge.com)

---

**From:** ColfaxNet Support <[support@colfaxnet.com](mailto:support@colfaxnet.com)>  
**Sent:** Thursday, April 11, 2019 8:28 AM  
**To:** Finato, Aaron <[AMFg@pge.com](mailto:AMFg@pge.com)>  
**Cc:** [support@colfaxnet.com](mailto:support@colfaxnet.com)  
**Subject:** Re: Document 065374

\*\*\*\*\***CAUTION: This email was sent from an EXTERNAL source. Think before clicking links or opening attachments.**\*\*\*\*\*

Hi Aaron:



Email correspondence with PG&E

Were you able to arrange with the inspector to meet at the site to go over their requirements?

We're ready to start digging.

Thank you,

Corey

On 4/2/2019 10:37 AM, Finato, Aaron wrote:

Thank you,

Aaron Finato  
Sr. New Business Representative  
Pacific Gas & Electric Company  
Service Planning  
12840 Bill Clark Way  
Auburn, CA 95602  
Cell: 530.559.7849  
E-Mail: [amfg@pge.com](mailto:amfg@pge.com)



Virus-free. [www.avg.com](http://www.avg.com)

--

Corey Juchau  
ColfaxNet Support Group  
PO Box 1597  
Colfax, CA 95713  
530.346.8411  
[support@colfaxnet.com](mailto:support@colfaxnet.com)

--

Corey Juchau  
ColfaxNet Support Group  
PO Box 1597  
Colfax, CA 95713  
530.346.8411  
[support@colfaxnet.com](mailto:support@colfaxnet.com)

Email correspondence with PG&E  
**Subject:** Re: Sierra Sky Court, Colfax / PG&E Application 116391856  
**From:** ColfaxNet Support <support@colfaxnet.com>  
**Date:** 4/18/2019, 8:11 PM  
**To:** "Finato, Aaron" <AMFg@pge.com>  
**CC:** support@colfaxnet.com

Thank you Aaron:

Please let us know about the inspector.

Corey

On 4/18/2019 8:46 AM, Finato, Aaron wrote:

Corey,

The panel needed requires a ring style meter sockets, so this will be insufficient. I can't verify if "horn bypass" is the equivalent to "test bypass". You're best off talking to an electric supply shop.

Still working on the scheduling of the inspector and preliminary design. I'm sorry. Hopefully early next week at this point.

Thanks,

**Aaron Finato** | Sr. New Business Representative  
Pacific Gas and Electric Company  
Service Planning  
12840 Bill Clark Way  
Auburn, CA 95602  
Phone: 530.889.3256  
Cell: 530.559.7849  
E-mail: [amfg@pge.com](mailto:amfg@pge.com)

---

**From:** ColfaxNet Support <[support@colfaxnet.com](mailto:support@colfaxnet.com)>  
**Sent:** Tuesday, April 16, 2019 8:23 PM  
**To:** Finato, Aaron <[AMFg@pge.com](mailto:AMFg@pge.com)>  
**Cc:** [support@colfaxnet.com](mailto:support@colfaxnet.com)  
**Subject:** Re: Sierra Sky Court, Colfax / PG&E Application 116391856

**\*\*\*\*\*CAUTION: This email was sent from an EXTERNAL source. Think before clicking links or opening attachments.\*\*\*\*\***

Hi Aaron:

Is the "Horn Bypass" the panel at <https://www.homedepot.com/p/Siemens-Uni-PAK-2-Gang-400-Amp->

[Ringless-Style-Multi-Family-Metering-With-Test-Bypass-WI-P211107300076452](#) is talking about the "Test-Bypass" you are referring to below?

Do you have an update as to when we will be able to meet the inspector at the site?

Did you find the Easement that is recorded with The County of Placer that we uploaded to the PG&E web site? Is this sufficient for the written agreement that you are referring to in your 4/13/19 E-mail?

Please let us know when you have a chance.

Thank you,

Corey

On 3/7/2019 10:58 AM, Finato, Aaron wrote:

Hi Corey,

Per our meeting onsite here are the items we discussed:

- The required PG&E enclosure will be: 17" x 30" x 26" (PG&E Code: 040929)
- Post Mounted Service construction requirements attached.
- Your electric panel must have "Test-Bypass" studs per PG&E Greenbook Standard, Section 7, Note 7.2.2. [PG&E Greenbook](#)

Please let me know if we're going to proceed with the plan discussed in the field. Lastly, let me know if you have any questions.

Thanks,

**Aaron Finato** | Sr. New Business Representative  
Pacific Gas and Electric Company  
Service Planning  
12840 Bill Clark Way  
Auburn, CA 95602  
Phone: 530.889.3256  
Cell: 530.559.7849  
E-mail: [amfg@pge.com](mailto:amfg@pge.com)

 Virus-free. [www.avg.com](http://www.avg.com)

--  
Corey Juchau  
ColfaxNet Support Group  
PO Box 1597  
Colfax, CA 95713

530.346.8411  
[support@colfaxnet.com](mailto:support@colfaxnet.com)

Email correspondence with PG&E

**Item 8A**  
33 of 49

--  
Corey Juchau  
ColfaxNet Support Group  
PO Box 1597  
Colfax, CA 95713  
530.346.8411  
[support@colfaxnet.com](mailto:support@colfaxnet.com)

Email correspondence with PG&E

**Subject:** New building permit  
**From:** ColfaxNet Customer Service <cs@colfaxnet.com>  
**Date:** 4/23/2019, 9:07 PM  
**To:** Aaron.finato@pge.com  
**CC:** cs@colfaxnet.com

Hi Aaron:

The City of Colfax issued us a new building permit for the trench on Sierra Sky Court in Colfax, CA. We uploaded it to the PG&E web site this evening.

Please let us know how it's going with estimating the project and meeting with the inspector at the site.

Thank you,

--  
Corey Juchau  
ColfaxNet Customer Service  
PO Box 1597  
Colfax, CA 95713  
530.346.8411  
[cs@colfaxnet.com](mailto:cs@colfaxnet.com)

---  
This email has been checked for viruses by AVG.  
<https://www.avg.com>

Email correspondence with PG&amp;E

**Subject:** Re: PG&E Notes  
**From:** ColfaxNet Support <support@colfaxnet.com>  
**Date:** 4/26/2019, 10:20 PM  
**To:** "Finato, Aaron" <AMFg@pge.com>  
**CC:** support@colfaxnet.com

Thank you Aaron.

Corey

On 4/26/2019 4:09 PM, Finato, Aaron wrote:

**PG&E Splice Box Material Code Number (Lid will be marked PG&E):** 019597

**PG&E Auburn Inspection Desk:** 530-889-3271

**Panel Description:** 100A Panel with Test Bypass, Ring Style Meter Socket, 120/240 1PH

Thank you,

**Aaron Finato** | Sr. New Business Representative  
Pacific Gas and Electric Company  
Service Planning  
12840 Bill Clark Way  
Auburn, CA 95602  
Phone: 530.889.3256  
Cell: 530.559.7849  
E-mail: [amfg@pge.com](mailto:amfg@pge.com)



Virus-free. [www.avg.com](http://www.avg.com)

--  
Corey Juchau  
ColfaxNet Support Group  
PO Box 1597  
Colfax, CA 95713  
530.346.8411  
[support@colfaxnet.com](mailto:support@colfaxnet.com)

# Attachment 5

**Item 8A**

**36 of 49**

Tree	Manufacturer	Proposed use of tower space Item	Height- approx	
Lower East Tree	UBNT	M5 w/ RF Armor shield	76	1
	Trango T45	Mesh grid	73	
	Mimosa	M24	71	1
	UBNT	AG-24	69	1
	Trango T45	14" panel	68	
	Mimosa	B5	64	1
	Mimosa	B5	60	1
S dead tree	UHF bow tie			
N dead tree	Trango	Tlink45-14"panel	47	
	Mimosa	B5	46	1
	Mimosa	B5c	45	1
		2' dish	45	
	UBNT	M5 w/ RF Armor shield	42	1
	UBNT	M5 w/ RF Armor shield	40	1
North tree	Airspan	3.65 BSR	70	1
	Hyperlink	4105hyp011	70	
	UBNT	M5 w/ RF Armor shield	65	1
	Mimosa	B5	65	1
	UBNT	M5 w/ RF Armor shield	65	1
	UBNT	M5	65	1
	Mimosa	B5	50	1
	UBNT	M5	45	1
	Mimosa	B5	35	1
	Middle Lower Tree	UBNT	AC5-W	83
Mimosa		B5c	80	1
		2' dish	80	
Tree top of drive on right	Mimosa	B5	70	1
				Total lbs



Options considered  
ColfaxNet, LLC  
PO Box 1597  
Colfax, CA 95713  
530.346.8411  
[cs@colfaxnet.com](mailto:cs@colfaxnet.com)

May 4, 2019

Amy Feagans  
City of Colfax Planning Department  
33 S Main Street  
Colfax, CA 95713

Amy:

Here is the list you requested of other options ColfaxNet is considering:

- Inspect property on Colfax Hill to determine feasibility of locating tower at different locations within Mr. Amick's property
- Lease space on the towers on hill to the South of our easement
  - Requested feasibility and price quotes from both tower companies. Currently waiting for their responses. They estimated they will provide middle of next week.
  - Would not work without significant reorientation of other sites' antennas
  - Additional site(s) would need to be obtained due to line-of-site restrictions
- Install 3 wooden utility poles in place of metal tower
- Move Colfax Hill equipment to an entirely different location
  - Would not work without significant reorientation of other sites' antennas
  - Additional site(s) would need to be obtained due to line-of-site restrictions
  - Extremely expensive



## **Attachment 5**

Options considered

- May not be able to obtain backbone connection depending on location of new site which would require additional sites to repeat signal to main hub
- Significant interruptions during transition

**Item 8A**

**38 of 49**

•



Proposed scope of work  
ColfaxNet, LLC  
PO Box 1597  
Colfax, CA 95713  
530.346.8411  
[cs@colfaxnet.com](mailto:cs@colfaxnet.com)

May 4, 2019

Amy Feagans  
City of Colfax Planning Department  
33 S Main Street  
Colfax, CA 95713

Amy:

Here is the scope of work for the Colfax Hill tower project.

1. Have licensed surveyor determine exact height of dead tree with equipment in it prior to removal
2. Install flush-mount junction box, power meter and 300' of 3" conduit from existing power transformer on Sierra Sky Court to tower site, using existing PUE along East side of Sierra Sky Court then up embankment to our 55' x 50' easement area
3. Install 6' x 6' concrete slab inside recorded easement
4. Install weatherproof equipment enclosure at site on 6' x 6' concrete slab
5. Install temporary Internet equipment to be used while tower is being installed
6. Remove two dead trees
7. Level out area where trees were to match area's grade

8. Paint tower a color to be determined by the City of Colfax Planning Department
9. Install tower at same location and height as dead tree that had equipment in it
10. Relocate and activate all equipment existing outside of recorded easement to new tower at various heights and orientations. (depending on adjacent tree cover) Paint Internet equipment the same color as tower
11. Clean up work area and remove all old wires, conduits and equipment on Mr. Amick's property

Timeline of proposed work  
**ColfaxNet Tower**  
Timeline

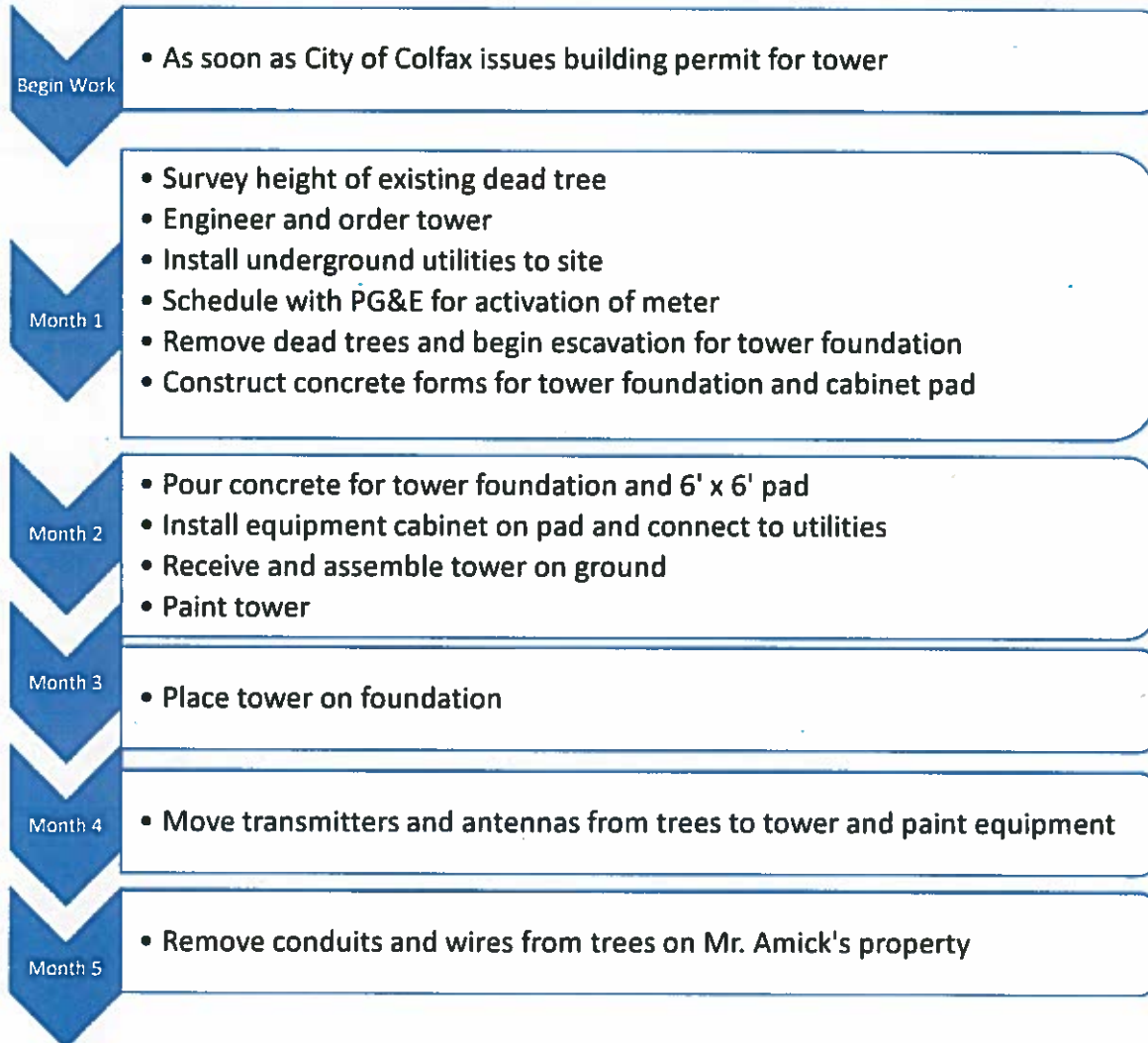



Letter dated 5/16/19 from Monti Reynolds,  
Reynolds Tilbury Woodward LLP,  
Attorney for applicant

**Item 8A**  
R. Monti Reynolds  
42 of 49  
rmreynolds@rtwlawllp.com

May 16, 2019

Members of the Colfax City Council

**Re: ColfaxNet - Application for Setback Variance**

Ladies and Gentlemen:

Our law firm represents ColfaxNet, Inc., a family business that has supplied high-quality, low-cost wireless internet service to the Colfax community for more than 18 years. The hub of ColfaxNet's wireless network antennas has been located for 15 years in two trees located within 15 feet of one another near the top of Colfax Hill. One of these trees, an approximately 65' pine, has died and is in danger of falling. Should this occur, it is estimated that 350 ColfaxNet customers, a number of whom live in the City of Colfax, immediately will lose internet service. ColfaxNet desires to replace the dead "tree tower" with a metal tower of roughly the same height in the same location, remounting the same antennas used in the dead tree and those near it on Colfax Hill. The dead tree to be replaced is close to a property line. ColfaxNet has requested a variance from setback requirements so that the location of the antennas in the dead tree and the adjacent trees can be replicated on the replacement tower.

Maintaining the near exact location of the antennas now located in the dead tree area is critical to the continued operation of the wireless network that supplies internet services to ColfaxNet's users. The network is based on line-of-sight transmissions and is constructed in a manner similar to a wagon wheel. The dead tree area antennas are the hub of the wagon wheel. The antennas at the end of each spoke of the wheel must be able to "see" the hub antennas in order for the network to function. Line-of-sight requirements are very exacting. A difference of 10 feet one way or another can be the difference between effective transmission and being blocked by a hill, tree or building. Due to the tree covered, hilly topography of Colfax, moving some of the antennas from their current locations by more than a few feet would break spokes in the network wheel.

It has been suggested that ColfaxNet artificially created the need for this variance by obtaining a deeded easement for the proposed tower that would not allow for placement outside the setback zone. First, the deeded easement matches a historic deeded easement of ColfaxNet's that was eliminated due to foreclosure on a previous landowner. It was the only area the current landowner was willing to allow ColfaxNet to occupy. Obtaining an easement elsewhere on the Amick property is a practical impossibility. More importantly,

this line of thinking ignores the unique nature of the dead tree tower location. ColfaxNet is not requesting to replace the tree tower in its exact location because it wants to be near a property line or due to the modest size of its easement on Colfax Hill. It needs to utilize the unique location of the dead tree tower. Even if a much larger easement could have been obtained (which it could not) ColfaxNet would still be seeking the variance to build at this location because it needs to have its antennas at the unique location where the hub can be located without breaking spokes in the wheel.

The only issue before the Council is a setback variance. If ColfaxNet were not tied to the unique location of the dead tree tower, it could build its tower outside a setback area on Colfax Hill without Council approval. The issue is not whether a tower of this type is appropriate on Colfax Hill. The Colfax Municipal Code, in keeping with state and federal law, has already answered that question. This is important to keep in mind because several issues have been raised which speak to the appropriateness of a tower or more accurately antennas. It is easy to lose sight of the one simple issue at hand in the face of emotional appeals speaking to matters already settled.

**A Variance is Appropriate**

The sole issue before the Council is whether a setback variance is appropriate to allow the tower location ColfaxNet needs. As we will show, a variance is appropriate.

**Variations and use permits are means of providing administrative relief from, or flexibility in, the application of zoning ordinances and regulations.** Most zoning laws are inherently of broad application, and are generally required to be uniform. (*cite omitted*). Variations, conditional use permits, and other administrative exceptions allow local governments to adjust zoning regulations or to provide site-specific regulations, consistent with the adopted zoning ordinance, **to avoid hardships or to achieve other appropriate goals**, without going to the extent of legislatively amending the zoning ordinance. See *Topanga Ass'n for a Scenic Community v County of Los Angeles* (1974) 11 C3d 506, 511. (*Lindgren & Matta, California Land Use Practice (2019), Section 7.19 emphasis added*)

In short, variations are a tool which gives the City Council the flexibility to prevent hardship or achieve other appropriate goals. As shown above, relocating the antenna away from the site of the dead tree tower will “break spokes” in the line of site network. This will result in hardship to numerous parties. Broken spokes will mean loss of internet service to some ColfaxNet users. If the break can be repaired by the installation of additional antenna towers and if ColfaxNet elects to install such towers, that disruption may be temporary. If new towers are not installed, the service loss will be permanent, resulting in hardship to the users and economic hardship to ColfaxNet. It is unclear if ColfaxNet could survive the additional expense of mending the “broken spokes” with new towers or losing the users, potentially resulting in the demise of the company, economic hardship to its owners and employees and loss of the best low cost internet service for all of its users in and outside of Colfax. (Note courts have affirmed local variations on the basis of factors tending to show purely economic hardship in the absence of relief. See,

*e.g., Zakessian v City of Sausalito (1972) 28 CA3d 794, 799*) If ColfaxNet can withstand the economic cost of additional towers, it may need to raise rates, causing a hardship on users. Perhaps most important, the new towers required to fix the breaks may have their own impacts. Will residents near these new towers raise complaints?

Granting the variance is the best choice to preserving the status quo: good low-cost wireless internet to Colfax residents and their neighbors; keeping ISP prices in check through maintaining competition and allowing a choice of ISPs, and retaining a locally based, locally focused company. Variances exist so that useful goals such as these can be achieved and hardships avoided.

Against these goals, the council should consider any hardships on the surrounding landowners. Because the only material change to the status quo is substituting a metal tower for a dead tree, the only change (and arguable hardship) is a visual one. As we will demonstrate below, that “hardship” is minor.

**Necessary Findings**

In order to grant ColfaxNet’s variance, the Colfax Municipal Code states that the Council should make four findings. ColfaxNet’s request for variance allows for each of these findings. They will be discussed individually below.

**Finding No. 1** *There are special circumstances applicable to the property, including size, shape, topography, location or surroundings, such that the strict application of the provisions of this zoning ordinance deprives the property of privileges enjoyed by other property in the vicinity and under identical land use.*

As stated above, there are special circumstances with respect to this particular site location. This unique site is the hub of a complex existing line-of-sight network designed to account for the unique tree-covered, hilly topography of Colfax Hill and the greater Colfax community. If the tower were moved as much as 10 feet in any direction, one or more of the spokes of the wagon wheel network would be broken. While a broken spoke might be repairable if an additional tower was erected that has line-of-sight between the relocated hub and the end of the spoke node, this solution would only contribute to a greater proliferation of antennas and towers.

The second special circumstance that should be considered is the previous existence of a tree tower in the identical location. The tower has occupied this exact site for more than 15 years. The only material change from the status quo is the replacement of a wooden structure, in the form of a tree, with a metallic structure. Benefits and burdens to all parties will remain unchanged except for a minor visual change. This is itself a special circumstance. In no other location will the status quo be so preserved.

A third special circumstance is the slope and vegetation of the property in question. If we were to assume ColfaxNet could obtain an easement anywhere on the Amick property (which it cannot) and if we were to accept the broken spokes in the network that relocation

would necessitate (which would cause severe hardship), the slope and vegetation of the Amick property would still make obtaining a suitable antenna height nearly impossible. The requested site is practically the highest point on the property. Each foot of elevation drop requires an increase of antenna height by a foot and a corresponding increase in the set back of two feet. The result is little or no footprint in the middle of the Amick property where a very tall antenna would need to be located. I suspect the neighbors would prefer a small tower nestled in the tree line to an Eifel tower towering above it from the middle of the property. This would justify a variance if the entire Amick property were in play. However, as a practical matter, access to any other site on the Amick property is unavailable.

**Finding No. 2** *The granting of the variance does not constitute a grant of special privileges inconsistent with the limitations upon other properties in the vicinity and zone in which the property is located.*

Properties of this zoning classification are allowed to have towers of this type. Granting a variance allowing the otherwise permitted tower to be built closer to a property line does not give this property a special privilege because other properties in the vicinity with similar zoning are allowed to have similar towers.

**Finding No. 3** *The granting of the variance does not allow a use or activity which is not otherwise expressly authorized by the regulations governing the subject parcel.*

There is no prohibition against having this tower for the purposes requested on the subject property. As such, the granting of the variance will not allow activity which is not otherwise expressly authorized.

**Finding No. 4** *The granting of the variance will not be detrimental to the public health, safety or welfare, or injurious to the property or improvements in such vicinity and land use district in which the property is located.*

Allowing the variance will not be detrimental to the public health or safety. The project maintains the status quo with the exception of exchanging wood for steel so public health and safety will be unaffected other than the positive effect of eliminating a tree that is in danger of falling.

Allowing the variance will not be detrimental to the welfare of the people of Colfax or injurious to property or improvements. If we discount the possibility for property damage posed by the dead tree tower, the only arguable impact on welfare or property is visual. The tower in question will not be noticeable from almost all of Colfax. By way of illustration, I would challenge anyone to spot the current antennas on the dead tree tower from any location other than Sierra Sky Court. The antenna can be seen from at least one place in downtown Colfax, specifically the parking lot of the US Bank building. It is a tiny dot of white buried in the tree line. It is miniscule compared to the three massive antennas located elsewhere on the ridge. Now imagine if that tiny white dot were painted a color



blending with the trees. For practical purposes, this installation should be difficult to spot from anywhere other than Colfax Hill.

The parties that will potentially see the tower are the residents of three properties located on Sierra Sky Court at the top of Colfax Hill. However, the tower should not be visible from any of these parties' residences. The only time when they would see the tower is while driving or walking on an approximately 100-yard stretch of road running directly beneath the tower. Even then, the visual impact will be minimized because, for most drivers, as the viewing angle to see the tower will be so great that it will be blocked by the roof of most automobiles. Realistically, the tower will only be viewed by drivers in convertibles and persons walking on the road below who will be able to look up at a very high angle.

Opponents to the tower have shown photos of the antennas in and around the existing dead tree which make the antennas appear large and obtrusive. Fortunately, these pictures were taken from locations where no human will ever be. They are close-up drone shots taken from a height of over 60 feet above the ground or 70 feet above the road nearest to the tower. As a result, the visual impact suggested by the photos is grossly misleading.

Considering impacts to public health, safety and welfare cannot be complete without considering the positive impacts contributed by this tower. As stated above, this tower is integral to the ColfaxNet network. That network is instrumental in providing useful public information at a low cost to the citizenry of Colfax and their neighbors beyond the city limits. In the case of some persons, ColfaxNet's service is their only available internet service. For others, ColfaxNet is the low-cost quality provider, without which, they might not be able to afford internet service. In many cases, ColfaxNet is the only alternative to its competitors. The demise of ColfaxNet would result in virtual monopolies for competitive internet service in certain areas of Colfax removing the benefits of healthy competition and lower prices for the members of the Colfax community.

### **All Those Other Issues**

The matter before the City Council is a simple variance request. It has been complicated by the emotional appeals of a handful of persons who have raised a number of irrelevant issues. I do not want to burden the Council or encourage the misdirection. Nonetheless a brief response may be helpful. Reserving the right to respond in more detail at a later date, let me address a few of the extra issues in outline form:

- Issue: Neighbors will have increased radiation exposure if the variance is granted.
  - The antennas have been in place for 14 years. All that is changing is what is holding the antennas.
  - Similar Towers and antennas are permitted by the zoning on Colfax Hill.
  - Radiation from the antennas is low and dissipates very rapidly based on the inverse square law.

- The relative harmlessness of antennas is recognized by federal, state and local laws allowing antennas to be placed almost anywhere.
  - The adjoining neighbor's residence is more than 400' from the existing antenna site.
  - The party allegedly most concerned with radiation maintains a directional antenna on his property that directs far more radiation to his residence than the ColfaxNet antennas.
- Issue: ColfaxNet is getting free land.
    - ColfaxNet negotiated and paid for a deeded easement for this site prior to Mr. Amick's ownership. Through no fault of ColfaxNet, the deeded easement was wiped out by foreclosure on a previous property owner, leaving ColfaxNet with prescriptive rights.
    - ColfaxNet negotiated and must pay Mr. Amick \$15,000 for the current deeded easement. (It has bought and paid for the easement twice.)
    - In the past ColfaxNet has provided cash, free internet and other concessions for locating its antennas on other sites.
  - Issue: There are construction and utility service issues.
    - Code compliance will be enforced by the Building Department which will monitor construction.
  - Issue: ColfaxNet's existing tree towers on Colfax Hill were improperly permitted.
    - No permits were obtained because no permits were required for these types of installations.
  - Issue: The owner of the Amick property's rights would be violated by the variance.
    - ColfaxNet has agreements with the Amick property owner that contemplate the granting of the variance.
    - Should ColfaxNet violate its agreements, the property owner is well represented and can enforce its agreements without concerning the City of Colfax.
  - Issue: The neighboring property owner's rights would be violated by the variance.
    - ColfaxNet's proposal seeks to preserve the status quo. It is only changing its antenna support from wood to steel. The change does not violate any property rights.
    - If the neighboring owner believes the existing status quo to be improper, it may address its concerns with ColfaxNet directly without involving the City of Colfax.

There is a common theme as to why these extraneous arguments are invalid. All we are proposing is replacing a wooden tree with a metal one. Maintaining the status quo harms no one.

**Conclusion**

For the reasons stated above, we respectfully request that the City Council approve the variance on behalf of ColfaxNet.

Should any members of the City Council or City Staff have any questions regarding this matter or if there is any information that can be provided to further assist in the process, please do not hesitate to contact our offices.

REYNOLDS TILBURY WOODWARD LLP

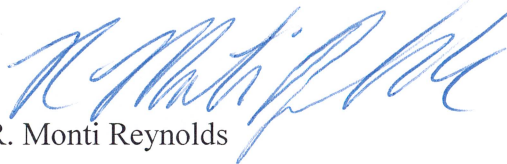

R. Monti Reynolds



THIS MAP IS NOT TO BE USED FOR NAVIGATION



# Staff Report to City Council

## FOR THE JUNE 26, 2019 REGULAR CITY COUNCIL MEETING

**From:** Wes Heathcock, City Manager  
**Prepared by:** Laurie Van Groningen, Finance Director  
**Subject:** Annual Appropriations Limit

*Budget Impact Overview:*

N/A: ✓	Funded:	Un-funded:	Amount:	Fund(s):
--------	---------	------------	---------	----------

**RECOMMENDED ACTION:** Adopt Resolution 29-2019 certifying compliance with the 2018-2019 Appropriation Limitation and establishing the Appropriation Limitation for the 2019-2020 Fiscal Year.

### Summary/Background

In 1979, California voters approved Proposition 4, an initiative that added Article XIII B to the *California Constitution*. This constitutional amendment, known as the Gann Initiative, placed limits on the growth of expenditures for publicly funded programs. Division 9 of Title 1, beginning with Section 7900 of the *Government Code*, was then added to law to specify the process for calculating state and local government appropriation limits and appropriations subject to limitation under Article XII B of the *Constitution*. These constitutional and statutory sections explain and define the appropriations limit and appropriations subject to limitation as they apply to state and local government, and require that each entity of government formally "adopt" its appropriations limit for a given fiscal year and certify actual appropriations limit for the preceding year.

The data required to complete the calculation is provided by the State of California, Department of Finance.

The appropriation limit is calculated based on two factors: a percentage change in population in conjunction with a change in the cost of living or price. Under Proposition 111, there are options available for each of the calculation factors:

- Population Factor – The City can elect to utilize the percent growth in City population or the percent growth in County population
- Price Factor – The City can elect to use the percent growth in State per capita personal income or the percent change in assessed valuation in new non-residential construction.

The population and price factors are multiplied together to calculate the Growth factor. The Growth factor is applied to the previous year calculated appropriated limit to determine the current fiscal year appropriation limit.

## Analysis

The Appropriations Limitation (Limit) imposed by the Propositions creates a restriction on the amount of revenue which can be appropriated in any fiscal year. Not all revenues are restricted by the Limit, only those which are referred to as “proceeds of taxes”. During any fiscal year, a city may not appropriate any proceeds of taxes they receive in excess of their Limit. In fact, any excess funds remaining after two years must be returned to the taxpayers.

Staff has been closely monitoring our Limit, especially as our estimated restricted revenues are expected to be at 85% of the fiscal year 2018-2019 approved Limit which does not leave much room for anticipated revenue growth. In preparation for the FY 2019-2020 review and calculation, the City contracted with Maze & Associates, CPA to complete a review and recalculation of the 2018-2019 Appropriations Limit for the City by multiplying the City’s Base Year (FY 1978-79) Appropriations Subject to Limitation by the Total Growth Factor for each fiscal year through 2019. Staff wanted to ensure that the most favorable factors were selected for each year and that any factors that were revised by the Department of Finance were adjusted accordingly.

The Independent Accountant’s report for this review is attached. The recalculated limit for fiscal year 2018-2019 is substantially different than previously calculated – primarily due to selecting the County population rate over the City population rate. The County population rate was higher than the City population rate in all but three of the past thirty-nine years (Note: The City started using the County rate in fiscal year 2017-2018). Implementing this recalculated accumulated growth base for future years Limit calculations will allow for anticipated growth in revenues in the coming years.

	Limit Amount	Estimated Restricted Revenues	% of Limit
FY 2018-2019 City approved Appropriation Limit	\$ 2,357,490	\$ 1,994,000	85%
FY 2018-2019 Recalculated Appropriation Limit	\$ 5,364,955	\$ 1,994,000	37%

### Fiscal Year 2019-2020 Appropriation Limit Calculation

In computing the Appropriation limit for fiscal year 2019-2020, the City is electing to use the Recalculated Limit for fiscal year 2018-2019. This does not change the Limit calculated and approved for previous years, but does allow accumulated growth based on the selection of more favorable factors to be applied to the calculated Limit going forward.

For the 2019-2020 calculation, the growth in Placer County population of 1.85% is more favorable than the City percent growth of .10% and has therefore been utilized in the calculation. For the price factor, the percentage change in State per capita income of 3.85% is used to calculate the Limitation. The population and price factors are multiplied together for a combined factor of 1.058. The combined

growth factor is applied to the recalculated fiscal year 2018-2019 Appropriation limit of \$5,364,955 to determine the fiscal year 2019-2020 limit of \$5,674,579.

Based on the fiscal year 2019-2020 budget the City will be well under its Appropriation Limit.

**Attachments**

1. Independent Accountant's Report on Applying Agreed Upon Procedures for Recalculating the City's Historical Appropriations Limit from Original Adoption in Fiscal Year 1981 to June 30, 2019.
2. Public Notice – Notice of Determination of appropriations Limit for the Fiscal Year 2019-2020
3. Resolution 29-2019
  - a. Attachment 1 – Estimated actual appropriation for the fiscal year 2018-2019
  - b. Attachment 2 – Appropriation Limit Calculation for fiscal year 2018-2019
4. Department of Finance Price and Population information for use in calculations for fiscal year 2019-2020 appropriations limit

**INDEPENDENT ACCOUNTANT'S REPORT ON  
APPLYING AGREED UPON PROCEDURES FOR  
RECALCULATING THE CITY'S HISTORICAL  
APPROPRIATIONS LIMIT FROM ORIGINAL ADOPTION  
IN FISCAL YEAR 1981 TO JUNE 30, 2019**



This Page Left Intentionally Blank



**INDEPENDENT ACCOUNTANT’S REPORT ON  
APPLYING AGREED UPON PROCEDURES FOR  
RECALCULATING THE CITY’S HISTORICAL  
APPROPRIATIONS LIMIT FROM ORIGINAL ADOPTION  
IN FISCAL YEAR 1981 TO JUNE 30, 2019**

Honorable Mayor and Members  
of the City Council  
City of Colfax, California

We have performed the procedures described below, which were agreed to by the City of Colfax, to recalculate the City’s historical Appropriations Limit from original adoption in fiscal year 1981 to June 30, 2019. The City’s management is responsible for the recalculate the City’s historical Appropriations Limit from original adoption in fiscal year 1981 to June 30, 2019. The sufficiency of these procedures is solely the responsibility of the City. Consequently, we make no representation regarding the sufficiency of the procedures described below either for the purpose for which this report has been requested or for any other purpose.

The procedures and associated findings are as follows:

1. We obtained the City’s Resolution No. 18-81 adopting the Appropriations Limit for fiscal year 1980-1981, including the attachment titled “Calculations Used in Setting Appropriations Limit for the City of Colfax FY 1980-81”.
2. We obtained the City’s Resolution No. 45-2018 adopting the Appropriations Limit for fiscal year 2018-2019, including Attachment 2 that details the Appropriations Limits for fiscal years 2009-2010 to 2018-2019.
3. We obtained the Price Factor and Population Information letters for fiscal years 1980 to 2019 from the California Department of Finance.
4. We recomputed the fiscal year 2018-2019 Appropriations Limit for the City by multiplying the City’s Base Year (FY 1978-79) Appropriations Subject to Limitation by the Total Growth Factor for each fiscal year through 2019. The Total Growth Factor for each year is the City population factor multiplied by the per capita income factor for fiscal years 1980 to 1987 and the larger of the City or County population factor multiplied by the per capita income factor for fiscal years subsequent to 1987. The results of the recalculations are detailed on **Attachment A**.

NOTE – this recalculation does not include adjustments related to any annexations or tax revenue sharing agreements that may have been executed during the above fiscal years.

This agreed-upon procedures engagement was conducted in accordance with attestation standards established by the American Institute of Certified Public Accountants. We were not engaged to and did not conduct an examination or review, the objective of which would be the expression of an opinion or conclusion, respectively, on the recalculation of the City's historical Appropriations Limit from original adoption in fiscal year 1981 to June 30, 2019. Accordingly, we do not express such an opinion or conclusion. Had we performed additional procedures, other matters might have come to our attention that would have been reported to you.

\*\*\*\*\*

This report is intended solely for the information and use of management and the City Council and is not intended to be and should not be used by anyone other than those specified parties; however, this restriction is not intended to limit the distribution of this report, which is a matter of public record.

*Maize & Associates*

Pleasant Hill, California  
June 3, 2019

City of Colfax  
 Historical Appropriations Limit Recalculation  
 Base Year (FY1978-79) to June 30, 2019

Year Ended 30-Jun	Beginning Limit	County Population	City Population	Per Capita Income	Recalculated Ending Limit	Adopted Limit	Difference
1980	\$342,784 (A)		(B) 1.2374	1.1017	\$467,298	\$461,139 (C)	\$6,159 (E)
1981	467,298		(B) 1.0367	1.1211	543,115	531,563 (D)	11,552 (E)
1982	543,115		(B) 1.0182	1.0912	603,433		
1983	603,433		(B) 1.0170	1.0679	655,361		
1984	655,361		(B) 0.9844	1.0235	660,298		
1985	660,298		(B) 0.9950	1.0474	688,138		
1986	688,138		(B) 0.9970	1.0374	711,733		
1987	711,733		(B) 0.9910	1.0230	721,550		
1988	721,550	1.0357	(B) 1.0020	1.0304	770,027		
1989	770,027	1.0445	(B) 1.0251	1.0393	835,902		
1990	835,902	1.0501	(B) 1.0243	1.0498	921,494		
1991	921,494	1.0561	1.0067	1.0421	1,014,161		
1992	1,014,161	1.0539	1.0292	1.0414	1,113,074		
1993	1,113,074	1.0391	1.0357	0.9936	1,149,193		
1994	1,149,193	1.0379	1.0115	1.0272	1,225,190		
1995	1,225,190	1.0320	1.0135	1.0071	1,273,374		
1996	1,273,374	1.0415	1.0480	1.0472	1,397,484		
1997	1,397,484	1.0321	1.0133	1.0467	1,509,700		
1998	1,509,700	1.0164	1.0014	1.0467	1,606,119		
1999	1,606,119	1.0261	1.0000	1.0415	1,716,432		
2000	1,716,432	1.0297	1.0101	1.0453	1,847,474		
2001	1,847,474	1.0300	0.9973	1.0491	1,996,330		
2002	1,996,330	1.0355	1.0212	1.0782	2,228,855		
2003	2,228,855	1.0395	1.0765	0.9873	2,368,890		
2004	2,368,890	1.0374	1.0369	1.0231	2,514,255		
2005	2,514,255	1.0305	0.9961	1.0328	2,675,922		
2006	2,675,922	1.0307	1.0089	1.0526	2,903,148		
2007	2,903,148	1.0262	0.9918	1.0396	3,097,187		
2008	3,097,187	1.0220	1.0038	1.0442	3,305,233		
2009	3,305,233	1.0211	1.0032	1.0429	3,519,759		
2010	3,519,759	1.0174	1.0097	1.0062	3,603,205	1,671,130 (F)	1,932,075
2011	3,603,205	1.0170	1.0567	0.9746	3,710,796	1,715,967 (F)	1,994,829
2012	3,710,796	1.0151	1.0072	1.0251	3,861,377	1,771,179 (F)	2,090,198
2013	3,861,377	1.0110	1.0056	1.0377	4,051,027	1,848,010 (F)	2,203,017
2014	4,051,027	1.0056	0.9960	1.0512	4,282,287	1,934,858 (F)	2,347,429
2015	4,282,287	1.0147	1.0050	0.9977	4,335,243	1,940,060 (F)	2,395,183
2016	4,335,243	1.0076	0.9970	1.0382	4,535,055	2,008,127 (F)	2,526,928
2017	4,535,055	1.0096	1.0019	1.0537	4,824,462	2,119,984 (F)	2,704,478
2018	4,824,462	1.0176	1.0078	1.0369	5,090,529	2,236,900 (F)	2,853,629
2019	5,090,529	1.0166	1.0014	1.0367	5,364,955	2,357,490 (G)	3,007,465

- (A) Beginning Appropriations Limit as of July 1, 1979 was obtained from the Attachment "Calculations Used in Setting Appropriations Limit for the City of Colfax FY1980-81" to the City's Resolution 18-81.
- (B) Prior to 1991, the City was allowed to use the City Population Growth Factor. For fiscal years 1991 and subsequent, the factor may be the larger of the City or County population growth. However, the City was also allowed to apply the 1988 to 1990 County growth factors to 1988 to 1990 when calculating the 1991 Limit (it did not change those prior year Limits).
- (C) Fiscal year 1980 Appropriations Limit was obtained from the Attachment "Calculations Used in Setting Appropriations Limit for the City of Colfax FY1980-81" to the City's Resolution No. 18-81.
- (D) Fiscal year 1981 Appropriations Limit was obtained from the City's Resolution No. 18-81.
- (E) Difference is due to State revising the per capita income and population factors in May 1981, subsequent to the City's calculation in April 1981, while the City's original calculations were based on the State's May 1980 estimate.
- (F) Fiscal year 2010 to 2018 Appropriations Limits were obtained from Attachment 2 to the City's Resolution No. 45-2018.
- (G) Fiscal year 2019 Appropriations Limit was obtained from the City's Resolution No. 45-2018.

This Page Left Intentionally Blank

## Attachment 2



# City Of Colfax

33 SOUTH MAIN STREET, COLFAX, CA

## PUBLIC NOTICE

### NOTICE OF DETERMINATION OF APPROPRIATIONS LIMIT FOR THE FISCAL YEAR 2019-2020

Section 7910 of the California Government Code requires each local government agency to determine during each fiscal year the appropriations limit pursuant to Article XIIB of the California Constitution applicable during the fiscal year. The limit must be adopted at a regularly scheduled meeting or at a noticed special meeting, and the documentation used in determining the limit must be made available for public review fifteen days prior to such meeting.

Set below is the methodology to be used to calculate the Fiscal Year 2019-2020 appropriations limit for the City. The limit is set forth below and will be considered and adopted at the regularly scheduled meeting of the Colfax City Council on June 26, 2019.

Appropriations Limit for FY 2018-2019	\$5,364,955	Limit recalculated - Independent Accountants Report dated 06/03/2019
Price Factor		
Change in California per capita	3.85%	Department of Finance - May 2019
Population Factor		
Placer County	1.85%	Department of Finance - May 2019
Combined Growth Factor	1.058	Price Factor x Population Factor (1.0385 x 1.0185)
Appropriations Limit for FY 2019-2020	\$5,674,579	Calculated Limit for fiscal year 2019-2020

Documentation is available for review at Colfax City Hall during regular work hours – Monday through Thursday, 8:00am to 5:00pm.

I, Jaclyn Collier, Customer Service Representative for the City of Colfax declare that this Notice was posted at Colfax City Hall and the Colfax Post Office. The Notice is also available on the City website at [www.Colfax-ca.gov](http://www.Colfax-ca.gov).

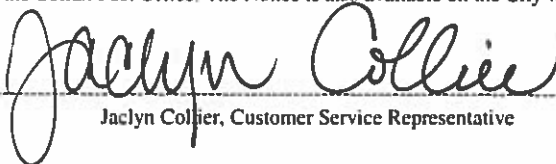

Jaclyn Collier, Customer Service Representative



Colfax City Council Meetings are ADA compliant. If you need special assistance to participate in this meeting, please contact the City Clerk at (530) 346-2313 at least 72 hours prior to make arrangements for ensuring your accessibility.

June 6, 2019

Page 1 of 1

# City of Colfax

## City Council

### Resolution № 29-2019

---

A RESOLUTION OF THE CITY COUNCIL OF THE CITY OF COLFAX  
CERTIFYING COMPLIANCE WITH THE 2018-2019 APPROPRIATION  
LIMITATION AND ESTABLISHING THE APPROPRIATION LIMITATION FOR  
THE 2019-2020 FISCAL YEAR

---

**WHEREAS**, the City Council of the City of Colfax hereby certifies that the estimated actual appropriations for the Fiscal Year 2018-2019 will fall within the appropriation limitation for the 2018-2019 Fiscal Year as demonstrated in Attachment 1; and,

**WHEREAS**, the City Council of the City of Colfax must establish the appropriation limitation for the fiscal year 2019-2020, as calculated in Attachment 2; and,

**NOW, THEREFORE, BE IT RESOLVED** by the City Council of the City of Colfax that the 2018-2019 Fiscal Year expenditures fall within the established limitations and the limitations for the 2019-2020 Fiscal Year are hereby established at \$5,674,579.

**THE FOREGOING RESOLUTION WAS DULY AND REGULARLY ADOPTED** at the Regular Meeting of the City Council of the City of Colfax held on the 26<sup>th</sup> day of June 2019 by the following vote of the Council:

**AYES:**

**NOES:**

**ABSTAIN:**

**ABSENT:**

---

**Joe Fatula, Mayor**

**ATTEST:**

---

**Wes Heathcock, City Manager**

**CITY OF COLFAX  
APPROPRIATION LIMIT CALCULATION  
Attachment 1**

<i>Tax Revenues to be included in calculation:</i>		<b>2018-2019 Actuals*</b>	<b>2019-2020 Budget</b>
100-000-4010	Property Taxes	\$ 360,000	\$ 369,338
100-000-4020	Sales and Use Taxes	\$ 1,350,000	\$ 1,400,000
100-000-4040	Transient Occupancy Taxes	\$ 16,000	\$ 16,000
100 (572)-000-4100	Franchises	\$ 85,000	\$ 85,000
100-000-4200	Business Licenses	\$ 31,000	\$ 31,000
100-000-4700	State Motor Vehicle License	\$ -	
100-000-4710	Motor Vehicle In Lieu	\$ 136,000	\$ 136,000
100-000-4030	Cannabis Business Tax	\$ 16,000	\$ 32,000
	<b>Total Tax Revenue</b>	<b>\$ 1,994,000</b>	<b>\$ 2,069,338</b>
Calculated Appropriation Limit		\$ 2,357,490	\$ 5,674,579
<i>Remaining appropriation limit capacity</i>		\$ 363,490 15%	\$ 3,605,241 64%

\*Estimate as of 05/31/2019



**City of Colfax  
Appropriation Limit Calculation  
Attachment 2**

	<u>2009-2010</u>	<u>2010-2011</u>	<u>2011-2012</u>	<u>2012-2013</u>	<u>2013-2014</u>	<u>2014-2015</u>	<u>2015-2016</u>	<u>2016-2017</u>	<u>2017-2018</u>	<u>2018-2019</u>	<u>2019-2020</u>
Computed Limit - Previous Year*	\$ 1,628,747	\$ 1,666,214	\$ 1,716,041	\$ 1,770,954	\$ 1,848,010	\$ 1,934,858	\$ 1,940,060	\$ 2,008,127	\$ 2,119,984	\$ 2,236,900	\$ 5,364,955
Price Factor											
Change in California per capita	1.0062	0.9746	1.0251	1.0377	1.0512	0.9977	1.0382	1.0537	1.0369	1.0367	1.0385
Population Factor**	1.0197	1.0567	1.0072	1.0056	0.996	1.005	0.997	1.0019	1.0176	1.0166	1.0185
Computed limitation	\$ 1,671,130	\$ 1,715,967	\$ 1,771,779	\$ 1,848,010	\$ 1,934,858	\$ 1,940,060	\$ 2,008,127	\$ 2,119,984	\$ 2,236,900	\$ 2,357,490	\$ 5,674,579
Combined Growth Factor	1.026	1.030	1.032	1.044	1.047	1.003	1.035	1.056	1.055	1.054	1.058

Note: \* Fiscal year 2018-2019 Limit recalculated back to the Base Year - Independent Accountants Report dated 06/03/19

\*\*Fiscal year 2019-2020 elected to use population factor for Placer County versus City of Colfax.



DEPARTMENT OF  
**FINANCE**

GAVIN NEWSOM - GOVERNOR

915 L STREET ■ SACRAMENTO CA ■ 95814-3706 ■ WWW.DOF.CA.GOV

May 2019

Dear Fiscal Officer:

**Subject: Price Factor and Population Information**

**Appropriations Limit**

California Revenue and Taxation Code section 2227 requires the Department of Finance to transmit an estimate of the percentage change in population to local governments. Each local jurisdiction must use their percentage change in population factor for January 1, 2019, in conjunction with a change in the cost of living, or price factor, to calculate their appropriations limit for fiscal year 2019-20. Attachment A provides the change in California's per capita personal income and an example for utilizing the price factor and population percentage change factor to calculate the 2019-20 appropriations limit. Attachment B provides the city and unincorporated county population percentage change. Attachment C provides the population percentage change for counties and their summed incorporated areas. The population percentage change data excludes federal and state institutionalized populations and military populations.

**Population Percent Change for Special Districts**

Some special districts must establish an annual appropriations limit. California Revenue and Taxation Code section 2228 provides additional information regarding the appropriations limit. Article XIII B, section 9(C) of the California Constitution exempts certain special districts from the appropriations limit calculation mandate. The code section and the California Constitution can be accessed at the following website: <http://leginfo.legislature.ca.gov/faces/codes.xhtml>.

Special districts required by law to calculate their appropriations limit must present the calculation as part of their annual audit. Any questions special districts have on this requirement should be directed to their county, district legal counsel, or the law itself. No state agency reviews the local appropriations limits.

**Population Certification**

The population certification program applies only to cities and counties. California Revenue and Taxation Code section 11005.6 mandates Finance to automatically certify any population estimate that exceeds the current certified population with the State Controller's Office. **Finance will certify the higher estimate to the State Controller by June 1, 2019.**

**Please Note:** The prior year's city population estimates may be revised.

If you have any questions regarding this data, please contact the Demographic Research Unit at (916) 323-4086.

KEELY BOSLER  
Director  
By:

Vivek Viswanathan  
Chief Deputy Director

Attachment

May 2019

Attachment A

- A. **Price Factor:** Article XIII B specifies that local jurisdictions select their cost of living factor to compute their appropriation limit by a vote of their governing body. The cost of living factor provided here is per capita personal income. If the percentage change in per capita personal income is selected, the percentage change to be used in setting the fiscal year 2019-20 appropriation limit is:

Per Capita Personal Income

Fiscal Year (FY)	Percentage change over prior year
2019-20	3.85

- B. Following is an example using sample population change and the change in California per capita personal income as growth factors in computing a 2019-20 appropriation limit.

**2019-20:**

Per Capita Cost of Living Change = 3.85 percent  
 Population Change = 0.47 percent

Per Capita Cost of Living converted to a ratio:  $\frac{3.85 + 100}{100} = 1.0385$

Population converted to a ratio:  $\frac{0.47 + 100}{100} = 1.0047$

Calculation of factor for FY 2019-20:  $1.0385 \times 1.0047 = 1.0434$

Fiscal Year 2019-20

**Attachment B  
Annual Percent Change in Population Minus Exclusions\*  
January 1, 2018 to January 1, 2019 and Total Population, January 1, 2019**

<b>County City</b>	<b>Percent Change 2018-2019</b>	<b>--- Population Minus Exclusions ---</b>		<b>Total</b>
		<b>1-1-18</b>	<b>1-1-19</b>	<b>Population 1-1-2019</b>
<b>Placer</b>				
Auburn	0.71	14,291	14,392	14,392
Colfax	0.10	2,071	2,073	2,073
Lincoln	0.98	47,808	48,277	48,277
Loomis	0.57	6,848	6,887	6,887
Rocklin	3.80	66,711	69,249	69,249
Roseville	2.48	136,260	139,643	139,643
Unincorporated	0.59	115,491	116,170	116,170
<b>County Total</b>	<b>1.85</b>	<b>389,480</b>	<b>396,691</b>	<b>396,691</b>

\*Exclusions include residents on federal military installations and group quarters residents in state mental institutions, state and federal correctional institutions and veteran homes.



# Staff Report to City Council

---

## FOR THE JUNE 26, 2019 REGULAR CITY COUNCIL MEETING

---

**From:** Wes Heathcock, City Manager  
**Prepared by:** Wes Heathcock, City Manager  
**Subject:** Clerk Services Agreement

*Budget Impact Overview:*

<b>N/A:</b>	<b>Funded:</b> √	<b>Un-funded:</b>	<b>Amount:</b> \$29,530	<b>Fund(s):</b> 100-120,560,561
-------------	------------------	-------------------	-------------------------	---------------------------------

**RECOMMENDED ACTION:** Discuss and consider adopting Resolution 30-2019 authorizing the City Manager to enter into an agreement with the City of Auburn in an amount not to exceed \$29,530.

### Summary/Background

The current vacancy in the City Clerk staff position provides a need for interim clerk services. The City of Auburn has agreed to provide interim clerk services through a shared services agreement (Agreement) for a 90-day term. The Agreement between agencies will provide Colfax coverage for clerk services, while staff recruits for a new City Clerk.

The scope of services is outlined in the attached Agreement, which include:

- Auburn to provide General Clerk Services to Colfax.
- The Auburn City Clerk will attend all regular meetings of the Colfax City Council.
- Auburn shall furnish and supply all necessary labor, supervision, equipment, and supplies necessary for such performance.

Staff is recommending City Council authorize the City Manager to enter into the Agreement for clerk services with the City of Auburn.

### Budget Impacts

The funding for the clerk services Agreement with the City of Auburn will be based on the City Clerk funding allocation, which includes Fund 100-120, 560, and 561.

### Attachments

1. Resolution 30-2019
2. Auburn-Colfax Clerk Services Agreement

# City of Colfax

## City Council

### Resolution № 30-2019

---

A RESOLUTION OF THE CITY COUNCIL OF THE CITY OF COLFAX  
AUTHORIZING THE CITY MANAGER TO ENTER INTO AN AGREEMENT  
WITH THE CITY OF AUBURN IN AN AMOUNT NOT TO EXCEED \$29,530

---

**WHEREAS**, the City of Colfax current vacancy in the City Clerk staff position provides a need for interim clerk services; and,

**WHEREAS**, the City of Auburn has agreed to provide interim clerk services through an Agreement for a 90-day term; and,

**WHEREAS**, Staff recommends council authorizing the City Manager to enter into an Agreement for clerk services with the City of Auburn.

**NOW, THEREFORE, BE IT RESOLVED** by the City Council of the City of Colfax authorizes the City Manager to enter into an agreement with the City of Auburn in an amount not to exceed \$29,530.

**THE FOREGOING RESOLUTION WAS DULY AND REGULARLY ADOPTED** at the Regular Meeting of the City Council of the City of Colfax held on the 26<sup>th</sup> day of June 2019 by the following vote of the Council:

**AYES:**

**NOES:**

**ABSTAIN:**

**ABSENT:**

---

**Joe Fatula, Mayor**

**ATTEST:**

---

**Wes Heathcock, City Manager**

**CLERK SERVICES AGREEMENT  
BY AND BETWEEN CITY OF AUBURN  
AND CITY OF COLFAX**

This CLERK SERVICES AGREEMENT (“Agreement”) is made and entered into effective **June 27, 2019** (“Effective Date”) by and between the City of Auburn, a California municipal corporation (“Auburn”), and the City of Colfax, a California municipal corporation (“Colfax”) (collectively, “Parties”).

**RECITALS**

WHEREAS, Colfax desires to contract with Auburn for the performance of General Clerk Services, as defined below, by the Auburn City Clerk in accordance with this Agreement;

WHEREAS, Auburn is agreeable to rendering such General Clerk Services to Colfax in accordance with this Agreement;

WHEREAS, Article 1 of Chapter 5 of Division 7 of Title 1 of the California Government Code (commencing with Section 6500) authorizes Auburn and Colfax by agreement to jointly exercise any power common to them including Clerk powers (the “Joint Exercise of Powers Act”); and

WHEREAS, Chapter 21 of Part 2 of Division 3.6 of Title 1 of the California Government Code (commencing with Section 895) authorizes Auburn and Colfax by agreement to provide for contribution or indemnification of any liability arising out of the performance of this Agreement.

NOW, THEREFORE, in consideration of the mutual promises contained herein, the Parties agree as follows:

**1. GENERAL PROVISIONS**

- 1.1. The Recitals above are true and correct and fully incorporated herein.
- 1.2. This Agreement is entered into pursuant to the provisions of the Joint Exercise of Powers Act.
- 1.3. The phrase “General Clerk Services” as used in this Agreement shall include all services currently provided by the Auburn City Clerk in the performance of her regular duties in that position.

## 2. SCOPE OF SERVICES

- 2.1. Auburn agrees to provide General Clerk Services to Colfax in accordance with this Agreement.
- 2.2. The Auburn City Clerk will attend all regular meetings of the Colfax City Council. The Auburn City Clerk shall perform all other work provided for under this Agreement from Auburn City Hall, unless approved in advance by the Auburn City Manager.
- 2.3. For purposes of performing General Clerk Services under this Agreement, Auburn shall furnish and supply all necessary labor, supervision, equipment, and supplies necessary for such performance. However, Colfax may provide additional equipment and supplies for Auburn to utilize in performing the General Clerk Services under this Agreement.

## 3. DEPLOYMENT OF PERSONNEL

- 3.1. Auburn shall provide General Clerk Services through the Auburn City Clerk pursuant to the Work Schedule attached hereto as Exhibit A. Colfax may request additional hours outside of those provided for in Exhibit A, subject to prior written approval by the Auburn City Manager.

## 4. ADMINISTRATION OF PERSONNEL

- 4.1. Except as specifically provided in this Agreement, the standards of performance and discipline and other matters incident to the performance of such services, including control of personnel so performing, shall remain with Auburn.
- 4.2. All Auburn employees working in conjunction with Colfax and/or Colfax employees under this Agreement shall remain Auburn employees and compensated by Auburn and shall not have any claim or right to employment, civil service protection, salary, benefits, compensation, or claims of any kind or nature from Colfax as a result of this Agreement.
- 4.3. All Colfax employees working in conjunction with Auburn and/or Auburn employees under this Agreement shall remain Colfax employees and compensated by Colfax and shall not have any



claim or right to employment, civil service protection, salary, benefits, compensation, or claims of any kind or nature from Auburn as a result of this Agreement.

## 5. INDEMNIFICATION

- 5.1. Colfax shall indemnify, defend, and hold harmless Auburn, and its officers, employees, agents, and volunteers, from and against any and all liabilities, losses, claims, damages, expenses, demands, and costs (including without limitation litigations costs and attorney, expert witness, and consultant fees) of every kind and nature arising out of a breach of Colfax's obligations under this Agreement, except where caused by the sole negligence or willful misconduct of Auburn, or its officers, employees, agents, or volunteers, or as otherwise required by law.
- 5.2. Colfax shall indemnify, defend, and hold harmless Auburn, and its officers, employees, agents, and volunteers, from and against any and all liabilities, losses, claims, damages, expenses, demands, and costs (including without limitation litigation costs and attorney, expert witness, and consultant fees) of every kind and nature arising out of the performance of General Clerk Services for Colfax under this Agreement.
- 5.3. The Parties agree that the covenants contained in this Section 5 of this Agreement shall survive the expiration or termination of this Agreement.

## 6. TERM OF AGREEMENT

- 6.1. This Agreement shall terminate ninety (90) days after the Effective Date, unless terminated before that date pursuant to section 6.2 of this Agreement.
- 6.2. This Agreement may be terminated at any time, with or without cause, by either of the Parties upon ten (10) days written notice to the other party as provided in this Agreement.
- 6.3. In the event of termination of this Agreement by either of the Parties: (1) the Parties shall fully discharge all obligations owed to each other accruing prior to the effective date of such termination, and (2) Colfax shall pay Auburn for all General Clerk Services

rendered prior to the effective date of such termination and properly billed as provided in this Agreement.

**7. BILLING AND PAYMENT PROCEDURES**

- 7.1. Colfax shall pay Auburn for the General Clerk Services rendered under this Agreement at a rate of \$61.52 per hour for applicable regular time worked and \$85.49 per hour for applicable overtime worked.
- 7.2. Auburn shall bill Colfax within ten (10) calendar days after the end of each calendar month by summarized invoice for the General Clerk Services provided in that month under this Agreement. The summarized invoice shall contain a statement of the number of hours worked. Colfax shall pay Auburn all amounts contained in such summarized invoice no later than thirty (30) days after receipt.

**8. NOTICES**

- 8.1. All notices and demands required or permitted to be given or made under this Agreement shall be in writing and either (1) hand delivered with signed receipt, or (2) mailed by first class registered or certified mail, postage prepaid and return receipt requested, addressed to the parties at the following addresses and to the attention of the person named. Addresses and persons named may be changed by either of the Parties by giving ten (10) days written notice to the other party.

If to City of Auburn:

If to City of Colfax:

City of Auburn  
 Attn: Robert Richardson, City Manager  
 1225 Lincoln Way  
 Auburn, CA 95603

City of Colfax  
 Attn: Wes Heathcock, City Manager  
 33 South Main Street  
 Colfax, CA 95713

- 8.2. All other communications required under this Agreement may be either (1) hand delivered with signed receipt or (2) mailed by first class mail, including the summarized invoices pursuant to Section 7.2 of this Agreement.

**9. WARRANTY OF AUTHORIZATION**

- 9.1. Auburn represents and warrants that the person executing this Agreement is a duly authorized representative of the City of

Auburn with actual authority to bind the City of Auburn to each and every term, condition, and obligation contained in this Agreement and that all requirements relating to such authority have been fulfilled.

- 9.2. Colfax represents and warrants that the person executing this Agreement is a duly authorized representative of the City of Colfax with actual authority to bind the City of Colfax to each and every term, condition, and obligation contained in this Agreement and that all requirements relating to such authority have been fulfilled.

## 10. MISCELLANEOUS PROVISIONS

- 10.1. This Agreement shall be governed and construed in accordance with the laws of the State of California. In the event of a dispute or claim arising out of this Agreement, venue shall be in the Superior Court of the State of California for the County of Placer.
- 10.2. This Agreement shall be construed as a whole and according to its fair meaning. This Agreement shall not be construed strictly for or against either of the Parties. If any provision of this Agreement is found unenforceable, void, or voidable by a court of competent jurisdiction, the remaining provisions shall continue in full force and effect.
- 10.3. This Agreement may be executed in counterparts such that the signatures appear on separate pages. A copy or facsimile of this Agreement, with all signatures appended together, shall be deemed a fully executed agreement. Signatures transmitted by facsimile or electronic means shall be deemed original signatures.
- 10.4. This Agreement represents the complete understanding of the Parties with respect to the matters set forth herein. This Agreement supersedes all previous agreements and understandings of the Parties, whether oral or written, with respect to the matters set forth herein. All such previous agreements and understandings shall have no force or effect.
- 10.5. Except as expressly provided herein, this Agreement may only be modified or amended by a written instrument executed by duly authorized representatives of the Parties.

10.6. The Parties agree to meet and confer periodically at mutually agreeable times to exchange relevant information and discuss performance under this Agreement.

\* \* \* \*

IN WITNESS WHEREOF, the City of Auburn by order of its City Council, and the City of Colfax by order of its City Council, have caused this Agreement to be executed by their duly authorized representatives as of the Effective Date:

CITY OF AUBURN,  
a Municipal Corporation

CITY OF COLFAX,  
a Municipal Corporation

By: \_\_\_\_\_  
Cheryl Maki  
Mayor

By: \_\_\_\_\_  
Name: \_\_\_\_\_  
Title: \_\_\_\_\_

ATTEST:

ATTEST:

By: \_\_\_\_\_  
Amy Lind  
City Clerk

By: \_\_\_\_\_  
Name: \_\_\_\_\_  
Title: \_\_\_\_\_

APPROVED AS TO FORM:

APPROVED AS TO FORM:

By: \_\_\_\_\_  
Gary B. Bell  
City Attorney

By: \_\_\_\_\_  
Name: \_\_\_\_\_  
Title: \_\_\_\_\_

**Exhibit A – Work Scope**

**Prepare City Council Agendas**

**Attend Regular City Council Meetings (including meeting setup and prep on day of – arrive at 5pm)**

**Record meeting actions and prepare necessary resolutions, ordinances and minutes**

**Coordinate Public Records Requests with Staff**

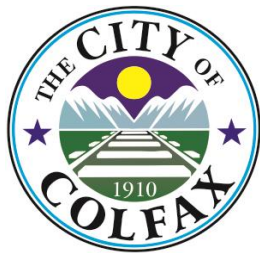

# Staff Report to City Council

---

## FOR THE JUNE 26, 2019 REGULAR CITY COUNCIL MEETING

---

**From:** Wes Heathcock, City Manager  
**Prepared by:** Amy Feagans, City Planner  
**Subject:** Ordinance No. 539 – An Ordinance Amending the Colfax Municipal Code Chapter 16.24 to Allow Amendment or Correction of Final Subdivision Maps

*Budget Impact Overview:*

N/A: ✓	Funded:	Un-funded:	Amount:	Fund(s):
--------	---------	------------	---------	----------

**RECOMMENDED ACTION:** Waive the second reading and by motion adopt the Ordinance No. 539 to allow Amendment or Correction of Final Subdivision Maps (Second Reading)

### Background/Summary

At the June 12, 2019, meeting Ordinance No. 539 was introduced as part of the Shadow Wood development project. The ordinance amends Chapter 16.24 of the Colfax Municipal Code to allow minor amendments or corrections of Final Subdivision Maps.

### Fiscal Impact

There is no fiscal impact as a result of adopting this ordinance.

### Staff Recommendation

Waive the second reading and by simple motion, adopt Ordinance No. 539.

### Attachments

1. Ordinance No. 539

CITY OF COLFAX

ORDINANCE NO. 539

**AN ORDINANCE OF THE CITY OF COLFAX AMENDING COLFAX MUNICIPAL CODE CHAPTER 16.24 TO ALLOW AMENDMENT OR CORRECTION OF FINAL SUBDIVISION MAPS**

The City Council of the City of Colfax does ordain as follows:

Section 1:

Colfax Municipal Code Chapter 16.24 is hereby amended by adding Section 16.24.060 as provided in the Ordinance attached hereto as Exhibit A which is incorporated herein by this reference.

Section 2. Superceding Provisions

The provisions of this Ordinance and any resolution adopted pursuant hereto shall supersede and repeal any previous Ordinance or resolution to the extent the same is in conflict herewith.

Section 3. Severability

If any section, phrase, sentence or portion of this Ordinance is for any reason held invalid or unconstitutional by the final judgment of any court of competent jurisdiction, such portion shall be deemed a separate, distinct and independent provision; and such holding shall not affect the validity of the remaining portions hereof.

Section 4. California Environmental Quality Act Findings

The City of Colfax finds that, if the provisions of the California Environmental Quality Act, Public Resources Code §21000 et seq (hereinafter "CEQA") apply, the title of this ordinance would constitute a brief description of the "Project" as required by Section 15062(a)(1) of the Guidelines for Implementation of the California Environmental Quality Act published by the State of California Office of Planning and Research (the "CEQA Guidelines").

FINDING OF NO PROJECT

The City of Colfax finds that adoption of this ordinance does not constitute a "Project" as that term is defined by or used in CEQA, the CEQA Guidelines or any court or attorney general opinion construing the same. Accordingly, the City of Colfax finds that the provisions of CEQA and the CEQA Guidelines are not applicable to said action.

FINDING OF EXEMPTION

In the event that it is found that the said action constitutes a "Project" as defined by or used in CEQA or the CEQA Guidelines, which finding would be contrary to the City's opinion of its action, the City of Colfax hereby finds that said action is exempt from compliance with CEQA and the CEQA Guidelines, for the following reasons: The action falls within the exemptions provided by Senate Bill 94, and within the "common sense" CEQA exemption provided in 14 CCR 15061(b)(3) in that CEQA applies only to projects which have the potential for causing a significant effect on the environment. Where it can be seen with certainty that there is no possibility that the action may have a significant effect on the

environment, the action is not subject to CEQA. CEQA Guidelines, Section 15061(b)(3). It can be seen with certainty that adoption of this ordinance and its provisions cannot possibly have a significant effect on the environment.

Section 5. Effective Date

This Ordinance, and all of its provisions, shall take effect thirty (30) days after its adoption and shall, within 15 days after its adoption, be published or posted in accordance with Section 36933 of the Government Code of the State of California with the names of those City Council members voting for and against it.

The foregoing Ordinance was introduced at a regular meeting of the City Council of the City of Colfax held on the 12th day of June, 2019, and passed at a regular meeting of the City Council held on the 26th day of June, 2019, at a duly held regular meeting of the City of Colfax, by the following vote:

AYES:  
NOES:  
ABSENT:

\_\_\_\_\_  
Joe Fatula, Mayor

APPROVED AS TO FORM:

ATTEST:

\_\_\_\_\_  
Alfred A. Cabral  
City Attorney

\_\_\_\_\_  
Wes Heathcock  
City Manager



CITY OF COLFAX

ORDINANCE NO. 539

**AN ORDINANCE OF THE CITY OF COLFAX  
AMENDING COLFAX MUNICIPAL CODE CHAPTER 16.24  
TO ALLOW MODIFICATION, AMENDMENT OR CORRECTION OF  
FINAL SUBDIVISION MAPS**

Colfax Municipal Code Chapter 16.24 is hereby amended by adding Section 16.24.060 as follows:

**16.24.060 Correction And Amendment Of Final Maps**

After a final map is filed in the office of the County Recorder, such final map may be modified, corrected or amended as provided for in the provisions of the California Subdivision Map Act that pertain or relate to correction and amendment of maps (California Government Code §§66469 – 66472.1) as amended, modified, supplemented, expanded or replaced from time-to-time.